

GENERAL NOTES

- ① See Standard Drawing E 720-SDCP-02 for casting details.
- ② See Standard Drawing E 720-SDCP-03 for casting details.
- ③ 3/8" x 1 1/2" stainless steel nonthreaded hex head bolt with locknut washer. (typ.)
- ④ Class A concrete, 6" min. thick. (typ.)
- 5. Cleanout ports shall be spaced at 250 ft or as shown on plans.

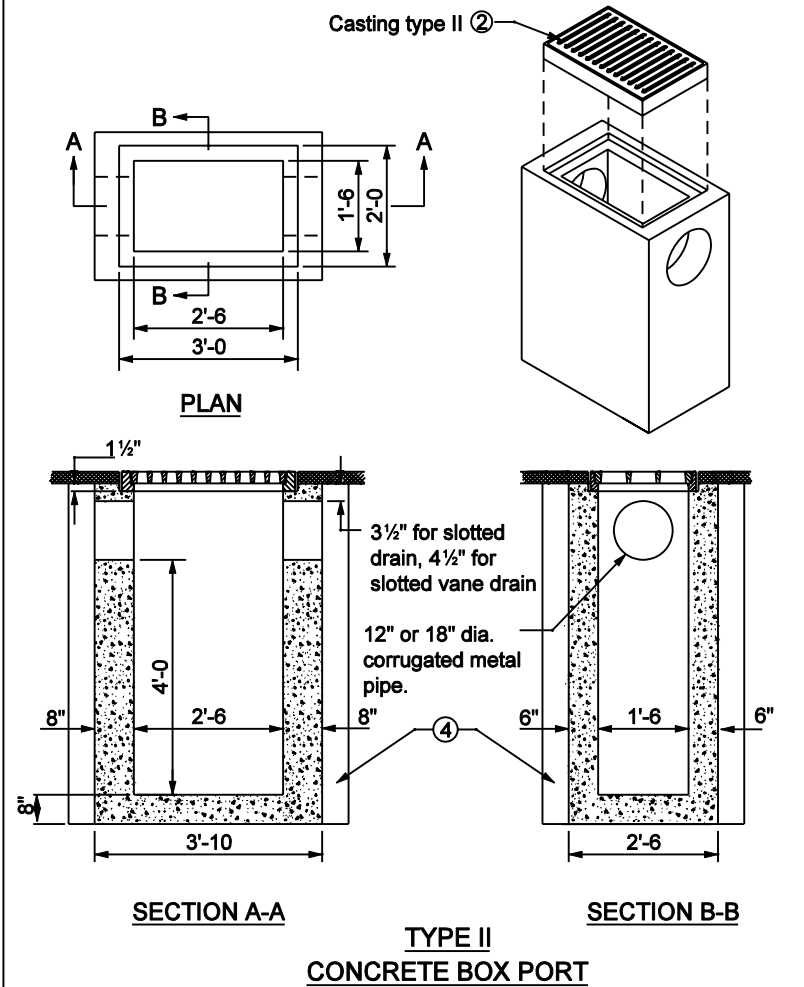
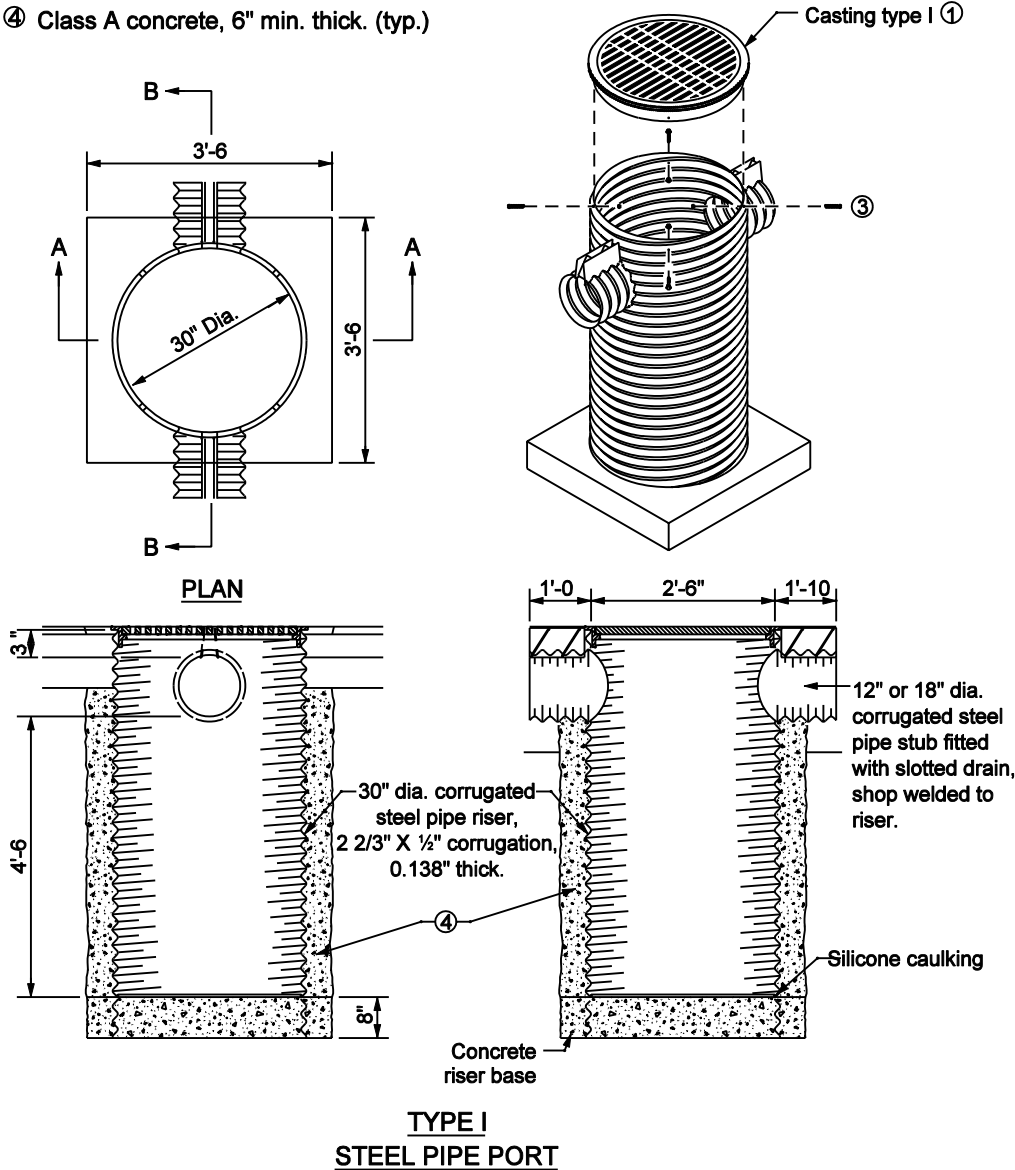

INDIANA DEPARTMENT OF TRANSPORTATION	
SLOTTED DRAIN PIPE CLEANOUT PORT	
MARCH 2003	
STANDARD DRAWING NO. E 720-SDCP-01	
	/s/ Richard L. VanCleave 3-03-03 DESIGN STANDARDS ENGINEER DATE
	/s/ Richard K. Smutzer 3-03-03 CHIEF HIGHWAY ENGINEER DATE
DESIGN STANDARDS ENGINEER	