

**CABINET SIDE PANEL  
POWER DISTRIBUTION**

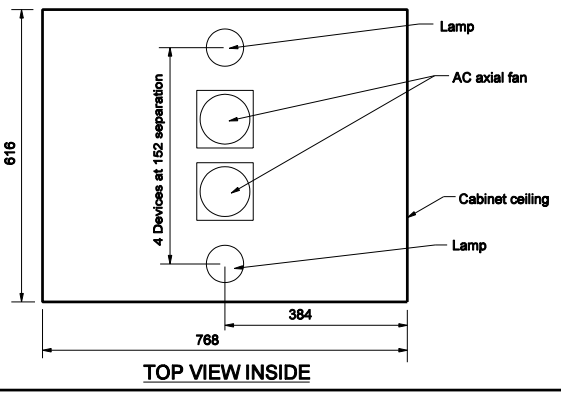

**TOP VIEW INSIDE**

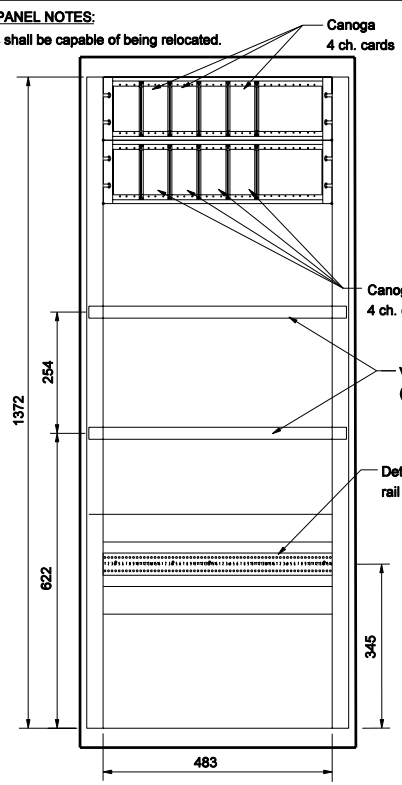

**FRONT ELEVATION**

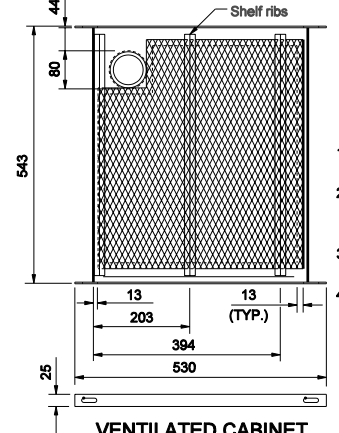

**VENTILATED CABINET  
SHELF BOTTOM VIEW**

- VENTILATED SHELF NOTES:**
- Tack weld screen to bottom of shelf.
  - Tack weld ribs over screen to bottom of shelf in locations shown.
  - Press bushing in from top of shelf.
  - Material Notes:**  
Shelf frame-3 alum.  
screen-3 expanded alum.w/13 mesh  
ribs - 3 x 16 x 16 alum. angle

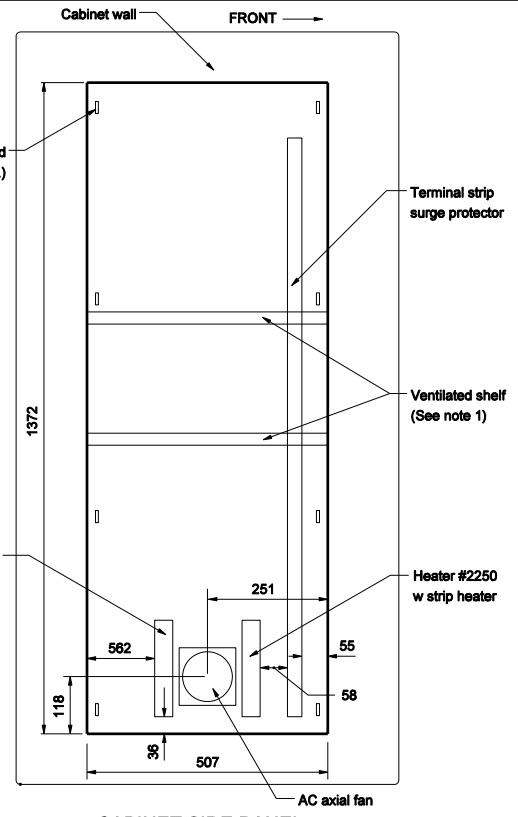

**CABINET SIDE PANEL  
HEATER**

**NOTES:**  
1. See Standard Drawings 809-ITCS-01, -01A or -03 thru -07 for additional ITS cabinet details.

All dimensions are in mm unless otherwise specified

INDIANA DEPARTMENT OF TRANSPORTATION

**INDOT ITS CABINET SCHEMATIC**

MARCH 2006

STANDARD DRAWING NO. 809-ITSC-02

	/s/ Richard L. VanCleave	3-01-06
	DESIGN STANDARDS ENGINEER	DATE
	/s/ Richard K. Smutzer	3-01-06
	CHIEF HIGHWAY ENGINEER	DATE

DESIGN STANDARDS ENGINEER