

NOTES :

- ② The limits for X are based on a 150 curb height. For other curb heights, the limits for X shall be adjusted.
- 3. See Standard Drawing 604-SDWK-01 or 604-SDWK-02 for sidewalk elevation transition details.
- 4. See Standard Drawing 610-DRIV-13 for General Notes.

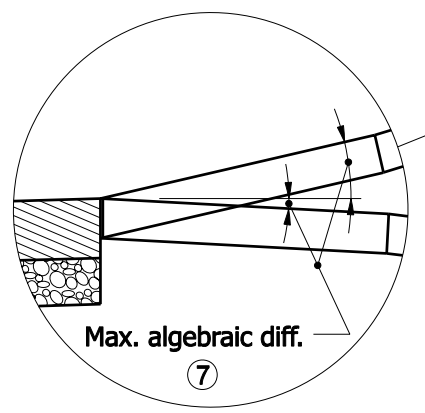

LEGEND

- W = Width of sidewalk
- X = Distance between back face of curb and sidewalk.
- Y = Distance from front face of curb to R or R/W
- Sidewalk elevation transition section view.
- PCCP

All Dimensions are in mm unless otherwise specified.

INDIANA DEPARTMENT OF TRANSPORTATION	
CLASS I AND CLASS III DRIVE GRADE PROFILES	
SEPTEMBER 2007	
STANDARD DRAWING NO. 610-DRIV-08	
	<p><i>/s/ Richard L. VanCleave</i> 09/04/07 <small>DESIGN STANDARDS ENGINEER DATE</small></p> <p><i>/s/ Mark A. Miller</i> 09/04/07 <small>CHIEF HIGHWAY ENGINEER DATE</small></p>
<small>DESIGN STANDARDS ENGINEER</small>	