

SPECIFICATIONS

for

Hampton Hall Lab Rooms 3291 and 3293 Renovation - 2024

**Purdue University
West Lafayette, Indiana**

**WBSE: C.40.12375
Building Index No: C-4**

June 26, 2024

Hampton Hall Lab Rooms 3291 and 3293 Renovation - 2024

Purdue University
West Lafayette, Indiana

June 26, 2024

Architectural
Certified by:

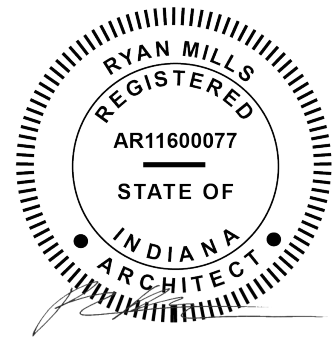

Ryan Mills
Registered Architect #AR11600077

Electrical
Certified by:



Stephen B, Culbert, P.E.
Professional Engineer #19400288

Mechanical
Certified by:



Tyler J. Heaston, P.E.
Professional Engineer #10809479

TABLE OF CONTENTS

Hampton Hall Lab Rooms 3291 and 3293 Renovation - 2024

Purdue University, West Lafayette, Indiana

June 26, 2024

BIDDING DOCUMENTS (UNBOUND) Provided loose with this Specification

Bid Form - Form 96

Standard Questionnaire and Financial Statement for Bidders (Form 96A)

BIDDING DOCUMENTS TO BE PROVIDED HEREIN OR BY ADDENDUM

Advertisement for Bids A-1

BIDDING DOCUMENTS

Instructions to Bidders B-1

Supplementary Instructions to Bidders C-1

Check List and Assembly of Bid D-1

Bid Form Insert E-1

Principal Subcontractor Questionnaire F-1

Subcontractor and Material Questionnaire G-1

Alternate Proposals H-1

Unit Prices I-1

Minority Business Enterprise Program Form J-1

Combination Bid Bond & Bond for Construction K-1

CONTRACTS

AIA A101-2017 Standard Form of Agreement Between Owner and Contractor L-1

AIA A101-2017 Exhibit A Insurance and Bonds L-8

CONTRACT FORMS

Certificate of Insurance (Acord 25 Form) M-1

Contract Change Order (Purdue Form 85) N-1

Construction Invoice Voucher (Purdue Form CIV) O-1

Compliance Affidavit (Purdue Form 25) P-1

Breakdown of Application for Payment (Purdue Form 87) Q-1

Contractor's Affidavit, Waiver of Claim and Lien, Certification and Guarantee (Purdue Form 86) R-1

E-Verify Program Affidavit S-1

Contribution by Tier 1 Contractor Affidavit T-1

GENERAL CONDITIONS

General Conditions of the Contract GC-1

ADDITIONAL INFORMATION

Project Location Map PLM-1

TABLE OF CONTENTS

HAMPTON HALL ROOMS 3291 & 3293 LAB RENOVATION - 2024

Purdue University, West Lafayette, Indiana
June 28, 2024

DIVISION 01 - GENERAL REQUIREMENTS

01 0100	PROJECT REQUIREMENTS
01 2900	PAYMENT PROCEDURES
01 3100	PROJECT MANAGEMENT AND COORDINATION
01 3216	CONSTRUCTION PROGRESS SCHEDULES
01 3523	OWNER SAFETY REQUIREMENTS
01 5000	TEMPORARY FACILITIES AND CONTROLS
01 7300	EXECUTION
01 7700	CONTRACT CLOSE-OUT

DIVISION 02 - EXISTING CONDITIONS

02 4119	SELECTIVE DEMOLITION
---------	----------------------

DIVISION 07 - THERMAL AND MOISTURE PROTECTION

07 8413	PENETRATION FIRESTOPPING
07 9200	JOINT SEALANTS

DIVISION 09 - FINISHES

09 2900	GYPSUM BOARD
09 6513	RESILIENT BASE AND ACCESSORIES
09 6519	RESILIENT TILE FLOORING
09 9124	INTERIOR PAINTING

DIVISION 12 – FURNISHINGS

123553.19	WOOD LABORATORY CASEWORK
-----------	--------------------------

DIVISION 20 - MECHANICAL SUPPORT

20 0500	COMMON MECHANICAL WORK RESULTS
20 0503	BASIC PIPING MATERIALS AND METHODS
20 0504	LABORATORY GENERAL PIPING AND EQUIPMENT REQUIREMENTS
20 0519	THERMOMETERS AND GAUGES
20 0523	GENERAL DUTY VALVES
20 0529	MECHANICAL HANGERS AND SUPPORTS
20 0553	MECHANICAL IDENTIFICATION
20 0700	MECHANICAL INSULATION

DIVISION 21 - FIRE SUPPRESSION

21 1000	WATER-BASED FIRE SUPPRESSION SYSTEMS
---------	--------------------------------------

DIVISION 22 – PLUMBING

22 1116	DOMESTIC WATER PIPING
22 1320	CHEMICAL RESISTANT WASTE AND VENT PIPING
22 6713	PROCESSED WATER PIPING

DIVISION 23 - MECHANICAL

23 0593	TESTING, ADJUSTING AND BALANCING
23 0900	HVAC INSTRUMENTATION AND CONTROLS
23 0993	SEQUENCE OF OPERATION

TABLE OF CONTENTS

HAMPTON HALL ROOMS 3291 & 3293 LAB RENOVATION - 2024

Purdue University, West Lafayette, Indiana
June 28, 2024

23 2113	HYDRONIC PIPING
23 3113	METAL DUCTS
23 3300	DUCT ACCESSORIES
23 3713	DIFFUSERS, REGISTERS, AND GRILLES
23 8217	REHEAT COILS

DIVISION 26 - ELECTRICAL

26 0001	BASIC ELECTRICAL REQUIREMENTS
26 0002	COMMON WORK RESULTS FOR ELECTRICAL
26 0003	TEMPORARY LIGHT AND POWER
26 0004	FIRESTOPPING
26 0005	MISC. WIRING METHODS AND SPECIAL REQUIREMENTS
26 0006	ELECTRICAL DEMOLITION
26 0526	GROUNDING AND BONDING FOR ELECTRICAL SYSTEMS
26 0529	HANGERS AND SUPPORTS FOR ELECTRICAL SYSTEMS
26 0533	RACEWAYS AND FITTINGS
26 0534	SURFACE METAL RACEWAYS
26 0553	ELECTRICAL IDENTIFICATION
26 0933	ARCHITECTURAL LIGHTING CONTROL SYSTEMS
26 2101	CONDUCTORS AND CABLES
26 2300	ENCLOSED SWITCHES AND CIRCUIT BREAKERS
26 2416	PANELBOARDS
26 2725	BOXES AND ENCLOSURES
26 2726	WIRING DEVICES
26 4113	LIGHTING PROTECTION FOR STRUCTURES
26 5100	LIGHTING EQUIPMENT
26 5113	LUMINAIRE LIST

DIVISION 27 - COMMUNICATIONS

27 0000	COMMUNICATIONS
27 0528	PATHWAYS
27 0553	IDENTIFICATION FOR COMMUNICATIONS SYSTEMS
27 1119	TERMINATION BLOCKS AND PATCH PANELS
27 1513	COPPER HORIZONTAL CABLING
27 1543	FACEPLATES AND CONNECTORS

END OF TABLE OF CONTENTS

ADVERTISEMENT FOR BIDS

The Trustees of Purdue University will receive sealed bids for the following project until 3:00 p.m. Eastern Daylight Time (EDT) on the 1st day of August 2024 in the offices of Capital Asset Management, 2550 Northwestern Avenue, Suite 1100, West Lafayette, IN 47906.

1. West Lafayette Campus – Hampton Hall Lab Rooms 3291 and 3293 Renovation – 2024

Bids will then be publicly opened and read aloud in the offices of Capital Asset Management, 2550 Northwestern Avenue, Suite 1100, West Lafayette, IN 47906.

Bids received after such time will be returned unopened. Bids may be withdrawn prior to such time, but no bids shall be withdrawn for a period of sixty (60) days thereafter.

The Principal Subcontractor Questionnaire listing the names of the bidder's principal subcontractors shall be submitted with the bid. The remainder of the Questionnaires and Material Lists shall be submitted prior to 3:00 p.m. (EDT) on the 8th day of August 2024, to:

Capital Asset Management
2550 Northwestern Avenue, Suite 1100
West Lafayette, IN 47906
Phone (765) 494-0580

Bids shall be for complete construction only, properly executed and submitted on Form 96, accompanied by executed Form 96A (as prescribed by the State Board of Accounts) giving financial data as recent as possible, and a Non-Collusion Affidavit together with other documents as required by the Instructions to Bidders and addressed to The Trustees of Purdue University, clearly marked with the project and the bid opening date.

Each bid must be accompanied by the Contractor's written plan for a program to test the contractor's employees for drugs in accordance with IC 4-13-18.

Each bid must be accompanied by a Contractor's Combination Bid Bond and Bond for Construction in the form included in the specifications made payable to The Trustees of Purdue University in an amount equal to the maximum total of the base bid and any alternate bids, guaranteeing the execution and faithful performance of the contract for the work if awarded.

The Instructions to Bidders contained in the specifications for the projects are by this reference made a part hereof, and all bidders shall be deemed advised of the provisions thereof, and of the General Conditions of the contract, specifications, plans and drawings for the project.

A voluntary pre-bid meeting for Project No. 1 will be held on July 9, 2024 at 2:00 p.m. EDT. The meeting will be held in Room 3291/3293 of Hampton Hall (HAMP), located at 550 Stadium Mall Dr., West Lafayette, IN.

The architectural/engineering firm for this project is:

Project No. 1 Synthesis Incorporated
 251 North Illinois Street, Suite 200
 Indianapolis, IN 46204
 Phone (317) 951-9500

To view or obtain bid documents online:

Repro Graphix Inc.
437 N. Illinois St
Indianapolis, IN 46204

Web: PurduePlanroom.com
Phone: 1-800-718-0035
Email: Plans@Reprographix.com

A \$300 deposit will be required for each hardcopy set of bidding documents. One compact disk or download is available at no charge. Postage and handling fee may apply.

All orders must be placed online but bidders may choose to pick up orders at:

Purdue Print & Digital Services delivered by Xerox:
698 Ahlers Drive
West Lafayette, IN 47907
Phone: 765-494-2006

Bidding Documents are on file in the office of:

Senior Vice President for Administrative Operations
2550 Northwestern Avenue, Suite 1100
West Lafayette, IN 47906
Phone (765) 494-0580

The Board of Trustees of The Trustees of Purdue University reserves the right to reject any and all bids and to waive, to the extent permitted by law, any of the terms, conditions and provisions contained in this Advertisement for Bids or the Instructions to Bidders or any informality, irregularity or omission in any bid, provided that such waiver shall, in the discretion of the Board of Trustees, be to the advantage of The Trustees of Purdue University.

THE TRUSTEES OF PURDUE UNIVERSITY

By

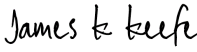
DocuSigned by:

95F8C862C768449...

James K. Keefe
Senior Director for Capital Asset Management

Date: 6/13/2024

INSTRUCTIONS TO BIDDERS

IB1.01 GENERAL

These Instructions to Bidders are a part of the Advertisement for Bids for the complete construction of the project in strict accordance with the Specifications, Plans and Drawings.

IB1.02 BID INCLUDES ALL COSTS

The amount of each Bid shall be deemed to include the entire cost and expense of every item of labor and material necessary to complete the work bid upon, in full detail ready for use and occupancy; and the risk of all such costs and expenses shall be deemed assumed by the successful Bidder. Bidders will not be given extra payment for conditions which could have been determined by examining the site and Contract Documents.

IB1.03 INTERPRETATION OF DOCUMENTS

Bidders contemplating submitting a Bid for the proposed project who are in doubt as to the true meaning of any part of the Contract Documents shall submit to the Architect listed in the Advertisement for Bids, (Legal company name) at least 10 days prior to the date for opening Bids, a written request for an interpretation.

Requests for interpretation may include (but are not limited to) any ambiguity, inconsistency, discrepancy, error or omission which occurs in the Contract Documents or for materials, equipment, or methods which in the Bidder's opinion adversely affect the cost or quality of the project, or are unavailable.

A Bidder's failure to request a clarification, interpretation, or correction of any ambiguity, inconsistency or error will preclude that Bidder from thereafter claiming for any reason, including the withdrawal of the Bid or in connection with a claim for "extras", any ambiguity, inconsistency or error which was either discovered by the Bidder or which should have been discovered by a reasonably prudent Bidder.

Any interpretation of the Contract Documents and any modification of the Contract Documents will be made only by an Addendum duly issued. A copy of such Addendum will be mailed or delivered to each person receiving a set of the Contract Documents and to such other prospective Subcontractors and material suppliers as have requested that they be furnished with a copy of each Addendum.

IB1.04 QUANTITIES

Stated quantities, if any, in the Contract Documents are approximate only and each Bidder shall make its own estimate of quantities and calculate its Bid accordingly.

IB1.05 SITE CONDITIONS

Bidders shall inform themselves of all the conditions under which the work is to be performed, including the site of the proposed work, any obstacles which may be encountered thereon, and all other relevant matters concerning the proposed work. Each Bid shall be deemed to include all costs and expenses in connection with all such conditions, obstacles and matters.

INSTRUCTIONS TO BIDDERS

Bidders shall make arrangements with the Owner's Physical Facilities Office for site visit. The Bidder's attention is directed to the provisions of Article 10 of the General Conditions and the Supplementary Conditions, if any, relating to Hazardous Waste.

IB1.06 SUBMISSION OF BIDS AND QUESTIONNAIRES

The Bidder shall submit its Bid on Form 96 as required in the Advertisement for Bids. Alternate Proposals and Unit Prices (if included in the Specifications) and acknowledgment of each Addendum (including date of Addendum and signature) shall be entered on Bid Form 96.

- A. In order for a Bid to be considered, each Bid shall be accompanied by the following documents:
1. Non-collusion affidavit
 2. Form 96A (See Section IB1.06C)
 3. Combination Bid Bond and Bond for Construction, in the form as set forth in the Specifications. The successful Bidder's bonding company will be notified of a contract to a firm they are bonding. The Bidder will need to provide contact name, mailing address and phone number of the bonding company with the bid. Bonds of unsuccessful Bidders will only be returned on request.
 4. Principal Subcontractor Questionnaire (if included in the Specifications). Principal Subcontractors listed are not permitted to be changed without the permission and approval of the Architect/Engineer.
 5. Proof of status as licensed Plumbing Contractor (if required by IB1.11).
 6. Proof of minority business enterprises (MBE) participation in accordance with the requirements of IB1.12 MINORITY CONTRACTORS.
 7. Contractor's written plan for a program to test the Contractor's employees for drugs in accordance with IC 4-13-18 (see Section IB1.14).
- B. Bid and accompanying documents shall be enclosed in a sealed opaque envelope. Envelope shall be addressed to the Trustees of Purdue University and clearly labeled with the following information:
1. Contents
 2. Project Title
 3. Name and Address of the Bidder
 4. Date and Time of Bid Opening
- C. Financial Information Form 96A:
- The financial information required by Form 96A shall be furnished as of the most recent date for which such information is available, and in no event shall such date be more than 12 months prior to the date of the Bid; furthermore, if such date is more than 90 days prior to the date of the Bid, the Bidder shall also furnish a written statement to the effect that as of the date of the Bid there have not been any changes which have materially and adversely affected the financial condition as set forth in Form 96A.

INSTRUCTIONS TO BIDDERS

D. Subcontractor Lists and Material Lists:

The low Bidder (and the second and third Bidders, if requested) shall execute and submit to the Owner within seven (7) days after the date and time for receiving Bids, in the forms included in the Specifications, the SUBCONTRACTOR LIST and MATERIAL LIST stating the names of the Bidder's Subcontractors and the various materials and appliances proposed to be furnished for the Project.

1. On these lists the Bidder shall submit only the names of the Subcontractors and manufacturers (or fabricators) of materials, appliances and specialties that the Bidder can, if required, fully demonstrate or prove they are capable of meeting the requirements of the Drawings and Specifications in all respects.
2. In such cases, the Architect shall give careful consideration to all matters submitted to the Architect by the Bidder. If in the Architect's opinion there is just cause for rejection, the Bidder shall submit substitute names for consideration until approved. The Bidder shall not be entitled to extra compensation for any such required substitute. Upon approval, the name submitted may not be changed by the Bidder without the permission and approval of the Architect.
3. Contractor shall submit evidence of all required certifications and other qualifications as detailed in the project specifications with these lists.

OWNER RESERVES THE RIGHT TO REJECT BID IF BIDDER FAILS TO SUBMIT DOCUMENTS PURSUANT TO THE INSTRUCTIONS SET FORTH ABOVE.

In order to effectively implement the objectives of the foregoing provisions and to assure the timely receipt of accurate Bids, the Bidder is requested to urge all Subcontractors intending to submit a proposal for work involved in the project to submit to all Bidders to whom they intend to bid, a written proposal (or written abstract) with or without price, outlining in detail the specific sections of the Specifications to be included in their work as well as any exceptions or exclusions there from. It is suggested that such written proposal be submitted to the Bidder at least 48 hours in advance of the Bid Opening.

E. Bid Signatures

Bids which are not signed by individuals making them shall have attached thereto a power-of-attorney evidencing authority to sign the Bid in the name of the person for whom it is signed.

Bids which are signed for a partnership shall be signed by all of the partners or by an attorney-in-fact. If signed by an attorney-in-fact, there shall be attached to the Bid a power-of-attorney evidencing authority to sign the Bid, executed by the partners.

Bids which are signed for a corporation shall have the correct corporate name thereof and the signature of the president or other authorized officer of the corporation, manually written below the corporate name following the word "By". If such a Bid is manually signed by an official other than the president of the corporation a certified copy of a resolution of the Board of Directors evidencing the authority of such official to sign the Bid shall be attached to the Bid. Such Bid shall also bear the attesting signature of the secretary of the corporation and the impression of the corporate seal.

INSTRUCTIONS TO BIDDERS

F. Modification or Withdrawal of Bid:

Any Bidder may withdraw his Bid at any time prior to the scheduled time for the receipt of Bids.

Bids may be modified any time prior to the scheduled time for the receipt of Bids.

Any Bidder may modify its Bid by facsimile communication or by U.S. Mail at any time prior to the scheduled closing time for receipt of Bids, provided such communication is received by the Owner prior to the closing time, and provided further, the Owner is satisfied that a written confirmation of the telegraphic modification over the signature of the Bidder was mailed prior to the closing time. The modifying communication should not reveal the Bid price but should only provide the addition or subtraction or other modification(s) so that the final prices or terms will not be known by the Owner until the sealed Bid is opened.

If written confirmation of the facsimile communication is not received within two days after the closing time, no consideration will be given to facsimile communication.

IB1.07 TIME OF COMPLETION

The attention of each Bidder is directed to the provisions of § 8.3.3 of the General Conditions of the Contract and Division One pertaining to time of completion.

IB1.08 CONTRACT

The successful Bidder shall be required to execute and deliver two (2) original copies each of the Contract (and three (3) copies of the Escrow Agreement, if required) and to deliver the policies and/or Certificate of Insurance - all within 10 days after the Contract is awarded. The Contract shall be deemed awarded when written Notice of Award has been delivered to the successful Bidder by facsimile transmission, followed with the original delivered via U.S. Mail addressed to the address of the Bidder as shown on its Bid or accompanying documents.

IB1.09 FORM OF CONTRACT

The Contract to be executed by the successful Bidder shall be in the form entitled "The Standard Form of Agreement Between Owner and Contractor where the basis for payment is a Stipulated Sum" – published by the American Institute of Architects with such insertions, additions, and changes are required by the successful Bid and Specifications. (The Owner will provide form for execution.)

IB1.10 SPECIAL PROVISIONS REGARDING RETAINAGE, BONDS AND PAYMENT OF CONTRACTORS AND SUBCONTRACTORS

The laws of the State of Indiana (IC 5-16-5.5-3 as amended) contain certain special provisions regarding retainage, bonds and payment of Contractors and Subcontractors. The contracts and subcontracts entered into between a Contractor and the Trustees of Purdue University in excess of \$200,000 will be governed by these provisions. The attention of the Bidder is called to the AIA A101 Exhibit A, Insurance and Bonds, regarding these provisions.

INSTRUCTIONS TO BIDDERS

IB1.11 LICENSED PLUMBING CONTRACTORS

To the extent that all or any portion of the work to be performed hereunder involves the installation of plumbing then each Bidder who submits a Bid must also submit, together with its Bid, evidence that the Bidder is a licensed Plumbing Contractor as defined in I.C. 25-28.5-1.

The following information will be acceptable as the required "evidence" (accompanying proof of license) for Complete Construction Bids.

Submit the proposed Subcontractor's License Number opposite the Subcontractor's Name on the PRINCIPAL SUBCONTRACTOR QUESTIONNAIRE.

At the time of submittal of the SUBCONTRACTOR LIST - MECHANICAL CONSTRUCTION include a photocopy of the Contractors License.

IB1.12 MINORITY CONTRACTORS

Bidders shall take all necessary and reasonable steps to ensure that minority business enterprises (MBE's) have the maximum opportunity to compete for and perform work included in the contract documents. For assistance in identifying MBE/WBE subcontractors and suppliers for your project, contact Purdue University's Office of Supplier Diversity Development at (765) 494-7270.

The award of the Contract will be made to the lowest and best Bidder when all other requirements have been met and good faith efforts have been taken towards meeting the stated MBE goal.

The Owner, at its discretion, may waive in part or in whole the minority business enterprise requirement if in the opinion of the Owner it would be impractical, or not in the best interest of the Owner.

MBE/WBE Program Forms:

A. With the Bid:

1. **MBE/WBE Subcontractor Plan form** - Bidders shall indicate minority business enterprises accepted by completing this form and placing (MBE/WBE) after the name listed on the Principal Subcontractor Questionnaire submitted with the Bid.
2. **MBE/WBE Program Documentation form** - Submit, on this form, an explanation of what positive efforts have been taken to achieve the stated MBE/WBE goal. Documentation of all outreach, contacts, and responses should be included. Reasons for acceptance or non- acceptance shall be so stated. Submission of incomplete explanations and documentation may result in the Bid being rejected.

INSTRUCTIONS TO BIDDERS

- B. By the date in the ADVERTISEMENT FOR BID (usually 7 days after bid opening):
1. **MBE/WBE Letter of Intent to Perform form** – The low Bidder, and the second and third, if requested, shall complete and submit as per the instructions on the form. The low Bidder, and the second and third, if requested, shall indicate MBE/WBE participation by Subcontractors and material suppliers by placing MBE/WBE after the names listed on the Subcontractor and Material Questionnaire submitted in accordance with the ADVERTISEMENT FOR BID.
 2. Bidders shall also submit proof of MBE/WBE certification for each MBE/WBE listed. Certification shall be by: State of Indiana Department of Administration Minority Business Development; Indiana Regional Minority Development Council; or Indiana Department of Transportation.
- C. During construction:
1. **Monthly MBE/WBE Utilization form** – On the larger projects (as determined by the Owner), the Contractor must submit this form monthly with their pay application as per its instructions and the provisions of § 13.8 of the General Conditions of the Contract.

IB1.13 ORGANIZATION OF SPECIFICATIONS AND DRAWINGS

Organization of the Specifications into divisions, sections and articles, and arrangement of Drawings shall not control the Contractor in dividing the work among Subcontractors or in establishing the extent of the work to be performed by any trade.

IB1.14 DRUG TESTING OF EMPLOYEES OF PUBLIC WORKS CONTRACTORS

The laws of the State of Indiana (IC 4-13-18 as amended) contain special provisions regarding drug testing of employees of public works Contractors and Subcontractors. As determined by the Owner, projects estimated to be in excess of \$150,000.00 will be governed by these provisions. The attention of the Bidder is called to the General Conditions of the Contract, §13.6, regarding these provisions.

IB1.15 SUBSTITUTIONS

- A. During Bidding, Architect will consider written requests from Prime Bidders for substitutions, received at least ten days prior to bid date; requests received after that time will not be considered.
- B. Submit two copies of request for substitution. Include in request:
1. Complete data substantiating compliance of proposed substitution with Contract Documents.
 2. Product Data:
 - a. Product identification, including manufacturer's name and address.
 - b. Manufacturer's literature:
 - i. Product description.
 - ii. Performance and test data.
 - iii. Reference standards.
 - c. Samples.

INSTRUCTIONS TO BIDDERS

- d. Name and address of similar projects on which product was used, and date of installation.
 3. Construction Methods:
 - a. Detailed description of proposed method.
 - b. Drawings illustrating methods.
 4. Itemized comparison of proposed substitution in comparison with product or method specified.
 5. Data relating to changes in construction schedule.
 6. Relation to other work.
 7. Accurate cost data on proposed substitution in comparison with product or method specified.
- C. In making request for substitution, Bidder/Contractor represents:
1. He has investigated proposed product or method, and determined that it is equal or superior in all respects to that specified.
 2. He will provide the same guarantee for substitution as for product or method specified.
 3. He will coordinate installation of accepted substitution into work, making such changes as may be required for work to be complete in all respects.
 4. He waives all claims for additional costs related to substitution which consequently become apparent.
 5. Cost data is complete and includes all related costs under this Contract.

IB1.16 (RESERVED)

IB1.17 OWNER SAFETY REQUIREMENTS

The Contractor performing work at the Project site shall, at no cost to the Owner, demonstrate commitment to workplace safety, safe work practices, and compliance with all applicable safety requirements. See Section 01 3523, Owner Safety Requirements.

The bidding contractor shall provide with the bid, their documentation in accordance with the requirements of Section 01 3523, unless the bidder is utilizing IOSHA's INSafe Program. If utilizing the INSafe Program, Contractor shall copy Purdue University with their request to INSafe for a consultation within 3 working days of being notified that they are the apparent low bidder.

IB1.18 CONTRACT AWARD AND SUBCONTRACTOR APPROVAL

Pursuant to I.C. 5-16-1-1.2 Purdue will award a contract for performance of the work to the "lowest and best bidder who submits a bid for the performance of the work." In determining the "lowest and best bidder" and the suitability of proposed subcontractors, Purdue reserves the right to consider all relevant factors including without limitation: ability and capacity, capital, character and reputation, competency and efficiency, energy, experience, facilities, faithfulness, fraud or unfairness in previous dealings, honesty, judgment, pending legal proceedings, promptness, quality of previous work, and suitability to the particular task. Information on pending litigation between Purdue and prospective bidders and subcontractors is available via the Court Records link at <http://www.tippecanoe.in.gov/>.

INSTRUCTIONS TO BIDDERS

IB1.19 CONTRACTOR PRE-QUALIFICATIONS

Pursuant to I.C. 5-16-13-10(c), bidders must be pre-qualified under I.C. 4-13.6-4 or I.C. 8-23-10. The attention of the Bidder is called to the General Conditions of the contract, § 13.15 regarding these provisions.

IB1.20 CONTRIBUTION BY TIER 1 CONTRACTOR

Pursuant to I.C. 5-16-13-9 The Tier 1 Contractor must contribute in work, material, services, or any combination thereof, at least fifteen percent (15%) of the awarded contract price. The Contractor shall execute and submit the Contribution by Tier 1 Contractor Affidavit to the Owner with its Waiver of Lien. The attention of the Bidder is called to the General Conditions of the Contract, § 13.13 regarding these provisions.

IB1.21 E-VERIFY PROGRAM

The laws of the State of Indiana (I.C. 5-16-13-11(1) and 22-5-1.7 as amended) contain special provisions regarding contractors enrolling and participating in the E-Verify program. The low Bidder (and the second and third Bidders, if requested), within seven (7) days after the date and time for receiving Bids, shall execute and submit the E-Verify Program Affidavit to the Owner. The attention of the Bidder is called to the General Conditions of the Contract, § 13.14 regarding these provisions.

SUPPLEMENTARY INSTRUCTIONS TO BIDDERS

THIS PAGE HAS BEEN LEFT BLANK INTENTIONALLY

CHECK LIST AND ASSEMBLY OF BID

Complete and assemble bids as listed below (one set to be submitted):

I. Bid Form Insert

- a. Use Bid Form No. 96 as provided filling in all information applicable and required under PART I for a complete and correctly prepared Bid Submittal.
- b. Use the Bid Form Insert, succeeding page(s), as a supplement to Bid Form No. 96.
 - i. The Bid Form Insert as prepared for this Project has spaces for the Base Bid, Complete Construction amount, Alternate Bid Proposals requested, and Addendum acknowledgment.
- c. This "Bid Form Insert" should be the first page of the bid package submitted.
- d. Do not use PART II of Bid Form 96. Use General Form No. 96A, Revised 1949, as issued with the Specifications to all Prime Bidders.

II. Bid Form No. 96

- a. The Non-collusion Affidavit located on the last page of the Bid Form No. 96, is to be signed by an officer of the company or corporation and notarized.
- b. The Bid Form No. 96 is to be signed on the lower half of the inside page, by an authorized individual or officer(s) of the company or corporation. If the Bid is signed by someone other than an officer of the company or corporation, a Board Resolution is to be submitted with the Bidding Documents giving said person signature authority.

III. Standard Questionnaire and Financial Statement for Bidders (Form 96a)

- a. Page 8 of the Form 96a is to be signed, dated and notarized.
- b. Page 9 of the Form 96a is to be dated. In no event shall the Financial Statement be dated more than 12 months prior to date of Bid. If the date is more than 90 days prior to the date of Bid, the Bidder shall submit a statement of their financial condition with their Bid as set forth in Section IB1.06(C) of the Instructions to Bidders.
- c. Statement of True Financial Condition section on page 15 of the Form 96a is to be signed and sealed as instructed.
- d. The appropriate Affidavit section on page 15 of the Form 96a is to be signed by an individual or officer of any company or corporation and notarized by a Notary Public.

IV. Combination Bid Bond & Bond for Construction

- a. The penal sum of the Contractor's Combination Bid Bond and Bond for Construction is to be for the maximum amount of the Bid. The maximum amount of the Bid is the total of the base bid plus all add alternates.
- b. The Combination Bid Bond and Bond for Construction as included in the Specifications is to be signed and dated on the second page by an officer of the company or corporation and the Bonding Company's representative. A copy of the power of attorney is to be attached to bond, authorizing said person to execute documents on behalf of the Bonding Company.

CHECK LIST AND ASSEMBLY OF BID

V. Principal Subcontractor Questionnaire

- a. If a Principal Subcontractor Questionnaire is included in the Specifications, it is to be filled out complete with one Subcontractor's name and address for each subcontract requested, and for any subcontract greater than \$150,000 (specifically requested or not) signed by an officer of the company or corporation, and submitted with the Bidding Documents.

VI. Minority Business Enterprise Program Forms

- a. Submit proof of minority business enterprises (MBE) participation in accordance with the requirements of IB1.12 MINORITY CONTRACTORS.

VII. Contractor's Written Drug Testing Program

- a. Submit contractor's written drug testing program in accordance with the requirements of IB1.14 DRUG TESTING OF EMPLOYEES OF PUBLIC WORKS CONTRACTORS. Requirement for the plan is determined by the owner's estimate of the project cost (for applicability, see Advertisement for Bid).

VIII. Compliance with Owner's Safety Requirements

- a. Submit documentation in accordance with the requirements of IB1.17 OWNER SAFETY REQUIREMENTS.

IX. Other Project Specific Documents

- a. If applicable, include any other remaining documentation required to be submitted with the bid.

BID FORM INSERT

Hampton Hall Lab Rooms 3291 and 3293 Renovation - 2024

Purdue University, West Lafayette, Indiana

Following notices given and having carefully examined the Contract Documents as well as the premises and conditions affecting the work, the undersigned proposes to furnish all labor and materials, necessary tools, expendable equipment, and all utility and transportation services and to perform all work required by and in strict accordance with the above named documents, prepared by Synthesis Incorporated, now on file in the office of the Vice President for Physical Facilities, Purdue University, West Lafayette, Indiana, and Synthesis Incorporated as stated below.

BID PROPOSALS

Bidder agrees to perform all items of work as shown on the Drawings and/or described in the Specifications or Addenda, for the amounts shown as follows: (Amount for Bids shall be shown in both words and figures. In case of discrepancy, the amount shown in words will govern).

SUBMITTED BY: _____

BASE BID: The complete construction as required by the Contract Documents for the sum of

_____ (\$ _____).

ALTERNATE PROPOSALS

Submit Alternate Bids on the respective Alternates as applicable to the Base Bid submitted. Use the space provided under the respective Alternates accordingly.

ALTERNATE NO. 1: Furnish and install ladder cable tray and gas cylinder racks.
(Add to/deduct from) the Base Bid the sum of: _____
_____ Dollars (\$ _____)

ALTERNATE NO. 2: N/A
(Add to/deduct from) the Base Bid the sum of: _____
_____ Dollars (\$ _____)

ADDENDA

The Bidder acknowledges receipt of the following Addenda:

ADDENDUM # _____ DATED _____
ADDENDUM # _____ DATED _____

PERSON AUTHORIZED TO SIGN CONTRACT (please print):

Name and Title: _____

Email: _____

PRINCIPAL SUBCONTRACTOR QUESTIONNAIRE

Hampton Hall Lab Rooms 3291 and 3293 Renovation - 2024

Purdue University, West Lafayette, Indiana

Principal Subcontractor Questionnaire

Submitted by _____

(To be submitted by each Bidder with his Bid)

Bidder to list subcontractors as requested below. **In addition to the requested subcontractors, Bidder to list all subcontractors that will have subcontracts greater than \$150,000.**

If awarded the complete construction contract, I/WE propose to have the following Subcontractors.

	<u>SUBCONTRACTOR - COMPLETE ADDRESS</u> (List the Subcontractor firms only)	Indicate if MBE/WBE/DBE
Lab Casework	_____ NAME	_____
	_____ ADDRESS	
Electrical Construction	_____ NAME	_____
	_____ ADDRESS	
Firestopping (Div 21)	_____ NAME	_____
	_____ ADDRESS	
Fire Suppression (Div 21)	_____ NAME	_____
	_____ ADDRESS	

Plumbing- Firestopping

NAME

ADDRESS

Plumbing

NAME

ADDRESS

Plumbing Insulation - Pipe

NAME

ADDRESS

HVAC Firestopping

NAME

ADDRESS

HVAC Insulation - Pipe

NAME

ADDRESS

HVAC Insulation - Duct

NAME

ADDRESS

Sheet Metal

NAME

ADDRESS

HVAC – Testing, Adjusting,
And Balancing

NAME

ADDRESS

These Subcontractors have been advised of the applicable labor provisions as set forth in the Contract Documents and these labor provisions will be included in all Subcontracts.

PRINTED NAME & TITLE

SIGNATURE

DATE

SUBCONTRACTOR AND MATERIAL QUESTIONNAIRE

SUBMITTED BY: _____

Hampton Hall Lab Rooms 3291 and 3293 Renovation - 2024

Each Bidder shall indicate under appropriate headings in the following form, the material, equipment, and specialties he proposes to incorporate in the work if awarded the Contract.

This form filled out in detail by the Bidder shall be submitted as required under "Instructions to Bidders".

The Bidder whose proposal is accepted will be required to furnish the materials, equipment and specialties he has listed herein unless such items do not, in the opinion of the Architect, comply with the requirements and intent of the Specifications and Plans. In the event that certain materials, equipment or specialties hereinafter listed by the successful Bidder do not, in the opinion of the Architect, comply with said requirements or intent, the successful Bidder will be required (as the Contractor) to furnish and substitute items which are in strict accordance with the Specifications and Plans and as approved by the Architect.

LIST OF SUBCONTRACTORS

If awarded the Construction Contract, I/We propose to employ the following listed Subcontractors:

<u>BRANCH OF WORK</u>	<u>NAME OF SUBCONTRACTOR</u>	Indicate if MBE/WBE
Lab Casework	_____	_____
Electrical Construction	_____	_____
Div 21 Firestopping	_____	_____
Fire Suppression	_____	_____
Plumbing Firestopping	_____	_____
Plumbing	_____	_____
Plumbing Insulation - Pipe	_____	_____
HVAC Firestopping	_____	_____
HVAC Insulation – Pipe	_____	_____
HVAC Insulation – Duct	_____	_____
Sheet Metal	_____	_____
HVAC Testing, Adjusting, Balancing	_____	_____

MATERIALS, EQUIPMENT, & SPECIALTIES

MANUFACTURERS (Not Subcontractors)

Resilient Base & Accessories	_____
Resilient Tile Flooring	_____
Wood Lab Casework	_____
Firestopping	_____
FS Pipe Hangers and Supports	_____
FS Steel Pipe	_____
FS Grooves Couplings	_____
FS Sprinkler Heads	_____
Plumbing (PL) Firestopping	_____

PL Copper Tubing	_____
PL Valves- Gate, Globe, Check	_____
PL Ball Valves	_____
PL Pipe Hangers and Supports	_____
PL Mechanical ID	_____
PL Mechanical Insulation:	_____
Pipe- Fiberglass	_____
Pipe- Elastomeric	_____
HVAC Firestopping	_____
HVAC Copper Tubing	_____
HVAC Strainers	_____
HVAC Valves- Gate, Globe, Check	_____
HVAC Valves- Ball	_____
HVAC Pipe Hangers and Supports	_____
HVAC Mechanical ID	_____
HVAC Mechanical Insulation:	_____
Pipe- Fiberglass	_____
Pipe- Elastomeric	_____
Duct- Fiberglass	_____
Equipment- Elastomeric	_____
HVAC Hydronic Systems	_____
HVAC Automatic Flow Control Valves	_____
HVAC Air Vents	_____
HVAC Air Distribution:	_____
Round Duct and Fittings	_____
Double Wall Round Duct and Fittings	_____
Spin-In Fittings	_____
Turning Vanes	_____
Volume Dampers	_____
Duct Access Doors	_____
Duct Liner- Fiberglass	_____
Grilles, Registers, and Diffusers	_____
Decentralized HVAC Equipment	_____
Reheat Coils	_____

ALTERNATE PROPOSALS

The base bid shall be submitted in strict accordance with the plans and specifications.

The deduction from, or addition to, the base bid for each numbered alternate shall include the cost of any changes in, additions to, or omissions from adjacent construction and materials necessary to properly install and complete the work even though such changes, additions to, or omissions are not specifically noted in the description of the alternate. No extra will be allowed for any such changes, additions, or omissions.

Each bidder shall state in their proposal the amount to be deducted from or added to the base bid for each and every alternate hereinafter described. If the base bid is not affected by any particular alternate proposal, bidder shall enter the amount of \$0.00 in the proper place on the Supplemental Bid Form.

BASE BID

State the amount required to complete all work shown on the drawings, herein specified and necessary to design and construct all scope described in the Construction Documents with the exception of the scope described in Alternate #1 below.

ALTERNATE NO. 1

Add to (or deduct from) the Base Bid the cost to furnish and install ladder cable tray and gas cylinder racks.

UNIT PRICES

SUBMITTED BY: _____

Hampton Hall Lab Rooms 3291 and 3293 Renovation - 2024

UNIT PRICES ARE NOT REQUIRED FOR THIS PROJECT.

MINORITY BUSINESS ENTERPRISE PROGRAM FORM

MBE/WBE/VBE SUBCONTRACTOR PLAN

PROJECT TITLE Hampton Hall Lab Rooms 3291 and 3293 Renovation - 2024

BIDDER _____ BID DATE _____

The following minority/women owned firms will be subcontracting on the project according to the following schedule:

Indicate MBE/WBE/VBE	MBE/WBE/VBE Firm	Trade	Amount	Contact Name	Phone

THIS DOCUMENT MUST BE INCLUDED IN YOUR SEALED BID PACKAGE

MINORITY BUSINESS ENTERPRISE PROGRAM FORM

DOCUMENTATION OF EFFORT TO MEET MBE/WBE/VBE PARTICIPATION GOAL

MBE/WBE Program Documentation is hereby submitted for the project listed below:

PROJECT TITLE Hampton Hall Lab Rooms 3291 and 3293 Renovation - 2024

BIDDER _____ BID DATE _____

Describe the efforts made to achieve the minority/women’s business enterprises participation goal for this project. Attach a copy of all solicitation efforts, e.g., ads that were published or networking events, etc.

- Unable to locate MBE/WBE/VBE engaged in _____ (Trade)
- Unable to secure competitive price in _____ (Trade)
- Other (See attached description)

LIST BELOW THE MBE/WBE/VBE FIRMS CONTACTED INDIVIDUALLY FOR THIS PROJECT

Indicate MBE/WBE/VBE	MBE/WBE/VBE Firms Contacted (list company and commodity)	Type of Attempt	Date(s) Attempted	Quote Rec'd – Not Low	No Response

THIS DOCUMENT MUST BE INCLUDED IN YOUR SEALED BID PACKAGE

MINORITY BUSINESS ENTERPRISE PROGRAM FORM

Hampton Hall Lab Rooms 3291 and 3293 Renovation - 2024

(project title)

MBE/WBE/VBE LETTER OF INTENT TO PERFORM

(To be completed by the MBE/WBE/VBE and submitted to pfpmc@purdue.edu by successful bidder prior to contract award.)

The MBE/WBE/VBE status of the undersigned must be confirmed prior to contract award. The undersigned intends to perform work in connection with the above

project as a: contractor subcontractor supplier joint venture

The undersigned has agreed to provide the following work, trades, services or supplies:

at the following price: \$ _____

The following commencement and completion dates for subcontracted work is:

Commencement Date: _____ Completion Date: _____

The undersigned will enter into formal contract or purchase order agreement with _____
_____ for the above work, trades, services or supplies contingent upon
prior execution of a contract between said company and
_____.

Name of Minority/Women/Veteran Contractor (please print)

Address

Phone No.

Company Office Name & Title (please print)

Signature

CONTRACTOR'S COMBINATION BID BOND AND BOND FOR CONSTRUCTION

Having submitted a bid or proposal ("Bid") dated _____ to enter into a binding contract ("Contract") with The Trustees of Purdue University ("Purdue") for the construction or demolition of the project known as Hampton Hall Lab Rooms 3291 and 3293 Renovation - 2024 ("Project"), in West Lafayette, Indiana the bidder/proposer _____ ("Principal") and _____ ("Surety")

represent, warrant and guarantee to Purdue that:

1. The Principal and Surety, jointly and severally, bind themselves, their heirs, executors, administrators, trustees, successors and assigns to the Owner for the performance of the Contract, which is completely incorporated by reference herein, in the penal sum of _____ Dollars (\$ _____).
2. If Purdue awards the Contract to the Principal and the Principal: a) enters into the Contract; b) performs the work required by the Contract; and c) promptly makes payment of all sums due and owing to persons making claim pursuant to the applicable provisions of I.C. 5-16-5, I.C. 5-16-5.5 or the equivalent provisions of I.C. 5-30, or I.C. 5-32, as the case may be, and defends, indemnifies and holds harmless Purdue from such claims or suits seeking payment for labor, material or equipment furnished for use in the performance of the Contract, then the Principal and Surety shall have no further obligation under this Bond.
3. If Purdue awards the Contract to the Principal pursuant to I.C. 5-16 and the Principal refuses, without substantial equitable justification, to enter into the Contract then the Principal and Surety shall be jointly and severally liable to Purdue in an amount equal to the difference between the Principal's Bid and that of the successful bidder/proposer.
4. If the Principal enters into the Contract and the Principal fails to perform in accordance with the requirements of the Contract, including without limitation the plans and specifications and any other documents identified in the Contract which establish the work to be performed by the Principal, Purdue shall give such notice to the Principal and Surety as may be required by the Contract or applicable statute and may thereafter declare the Principal to be in default and terminate the Contract. The Principal and Surety shall then be jointly and severally liable to Purdue for all costs reasonably and necessarily incurred by Purdue in completing the Project. If the Surety does not proceed to promptly make arrangements satisfactory to Purdue for completion of the Project then the Surety shall be in default of its obligations under this Bond and seven days after receipt of an additional notice from Purdue to this effect Purdue shall be entitled to enforce any remedy available to it under law.

CONTRACTOR’S COMBINATION BID BOND AND BOND FOR CONSTRUCTION

5. The Principal and Surety acknowledge Principal’s obligations under the Contract and applicable statutes to make payment to subcontractors, laborers, material-men and those furnishing or supplying labor or material for and on account of the work called for by the Contract. This Bond shall inure directly to the benefit of all persons or entities entitled to make claim pursuant to I.C. 5-16-5, I.C. 5-16-5.5, or the equivalent provisions of I.C. 5-30 or I.C. 5-32 as the case may be.
6. If the Principal enters into the Contract and claims are made, or suits filed, by persons or entities against Purdue or Purdue’s property seeking payment for labor, material or equipment furnished for use in the performance of the Contract then the Principal and Surety shall, defend, indemnify and hold harmless Purdue from and against any such claims or suits.
7. Purdue shall give Principal and Surety all notices required by the Contract or applicable statute; however, the failure of Purdue to give such notice shall not affect or invalidate the rights of the person, firm, limited liability company, or corporation to whom money may be due on account of having performed labor or service or having furnished material and shall not operate as a defense for the Surety on this Bond.
8. The Surety hereby waives notice of any change, including changes of time, to the Contract, any documents constituting a part of said Contract, or related subcontracts, purchase orders and other obligations of the Principal. No irregularity or defect in the Contract or in the letting, awarding, or execution of it or in any of the proceedings preliminary thereto shall in any way operate to release or discharge the Surety, whether or not the Surety has notice of it.

IN WITNESS THEREOF, we have hereunto set our hands and seals this _____ day of _____, 20____.

SURETY

PRINCIPAL

	Company Name	
	Signature	
	Printed Name, Title	

Bonding Agency: _____
 Agent: _____
 Email Address: _____
 Address: _____
 Phone: _____



AIA® Document A101® – 2017

Standard Form of Agreement Between Owner and Contractor where the basis of payment is a Stipulated Sum

AGREEMENT made as of _____.

BETWEEN the Owner:
(Name, legal status, address and other information)

The Trustees of Purdue University
2550 Northwestern Ave., Suite 1100
West Lafayette, IN 47906

and the Contractor:
(Name, legal status, address and other information)

for the following Project:
(Name, location and detailed description)

The Architect:
(Name, legal status, address and other information)

The Owner and Contractor agree as follows.

ADDITIONS AND DELETIONS:

The author of this document has added information needed for its completion. The author may also have revised the text of the original AIA standard form. An *Additions and Deletions Report* that notes added information as well as revisions to the standard form text is available from the author and should be reviewed. A vertical line in the left margin of this document indicates where the author has added necessary information and where the author has added to or deleted from the original AIA text.

This document has important legal consequences. Consultation with an attorney is encouraged with respect to its completion or modification.

The parties should complete A101®–2017, Exhibit A, Insurance and Bonds, contemporaneously with this Agreement. AIA Document A201®–2017, General Conditions of the Contract for Construction, is adopted in this document by reference. Do not use with other general conditions unless this document is modified.

Init.

TABLE OF ARTICLES

1	THE CONTRACT DOCUMENTS
2	THE WORK OF THIS CONTRACT
3	DATE OF COMMENCEMENT AND SUBSTANTIAL COMPLETION
4	CONTRACT SUM
5	PAYMENTS
6	DISPUTE RESOLUTION
7	TERMINATION OR SUSPENSION
8	MISCELLANEOUS PROVISIONS
9	ENUMERATION OF CONTRACT DOCUMENTS

EXHIBIT A INSURANCE AND BONDS

ARTICLE 1 THE CONTRACT DOCUMENTS

The Contract Documents consist of this Agreement, Conditions of the Contract (General, Supplementary, and other Conditions), Drawings, Specifications, Addenda issued prior to execution of this Agreement, other documents listed in this Agreement, and Modifications issued after execution of this Agreement, all of which form the Contract, and are as fully a part of the Contract as if attached to this Agreement or repeated herein. The Contract represents the entire and integrated agreement between the parties hereto and supersedes prior negotiations, representations, or agreements, either written or oral. An enumeration of the Contract Documents, other than a Modification, appears in Article 9.

ARTICLE 2 THE WORK OF THIS CONTRACT

The Contractor shall fully execute the Work described in the Contract Documents, except as specifically indicated in the Contract Documents to be the responsibility of others.

ARTICLE 3 DATE OF COMMENCEMENT AND SUBSTANTIAL COMPLETION

§ 3.1 The date of commencement of the Work shall be:

(Check one of the following boxes.)

- The date of this Agreement.
- A date set forth in a notice to proceed issued by the Owner.
- Established as follows:
(Insert a date or a means to determine the date of commencement of the Work.)

If a date of commencement of the Work is not selected, then the date of commencement shall be the date of this Agreement.

§ 3.2 The Contract Time shall be measured from the date of commencement of the Work.

§ 3.3 Substantial Completion

§ 3.3.1 Subject to adjustments of the Contract Time as provided in the Contract Documents, the Contractor shall achieve Substantial Completion of the entire Work:

(Check one of the following boxes and complete the necessary information.)

- Not later than () calendar days from the date of commencement of the Work.

Init.

/

[] By the following date:

§ 3.3.2 Subject to adjustments of the Contract Time as provided in the Contract Documents, if portions of the Work are to be completed prior to Substantial Completion of the entire Work, the Contractor shall achieve Substantial Completion of such portions by the following dates:

Portion of Work

Substantial Completion Date

§ 3.3.3 If the Contractor fails to achieve Substantial Completion as provided in this Section 3.3, liquidated damages, if any, shall be assessed as set forth in Section 4.5.

ARTICLE 4 CONTRACT SUM

§ 4.1 The Owner shall pay the Contractor the Contract Sum in current funds for the Contractor's performance of the Contract. The Contract Sum shall be (\$), subject to additions and deductions as provided in the Contract Documents.

§ 4.2 Alternates

§ 4.2.1 Alternates, if any, included in the Contract Sum:

Item

Price

§ 4.2.2 Subject to the conditions noted below, the following alternates may be accepted by the Owner following execution of this Agreement. Upon acceptance, the Owner shall issue a Modification to this Agreement. *(Insert below each alternate and the conditions that must be met for the Owner to accept the alternate.)*

Item

Price

Conditions for Acceptance

§ 4.3 Allowances, if any, included in the Contract Sum: *(Identify each allowance.)*

Item

Price

§ 4.4 Unit prices, if any:

(Identify the item and state the unit price and quantity limitations, if any, to which the unit price will be applicable.)

Item

Units and Limitations

Price per Unit (\$0.00)

§ 4.5 Liquidated damages, if any:

(Insert terms and conditions for liquidated damages, if any.)

§ 4.6 Other:

(Insert provisions for bonus or other incentives, if any, that might result in a change to the Contract Sum.)

ARTICLE 5 PAYMENTS

§ 5.1 Progress Payments

§ 5.1.1 Based upon Applications for Payment submitted to the Architect by the Contractor and Certificates for Payment issued by the Architect, the Owner shall make progress payments on account of the Contract Sum to the Contractor as provided below and elsewhere in the Contract Documents.

Init.

/

§ 5.1.2 The period covered by each Application for Payment shall be one calendar month ending on the last day of the month:

Not later than ten (10) days following the end of the period covered by the Application for Payment ninety-five percent (95%) of the portion of the Contract Sum properly allocable to labor, materials and equipment incorporated in the Work and ninety-five percent (95%) of the portion of the Contract Sum properly allocable to materials and equipment suitable stored at the site or at some other location agreed upon in writing, for the period covered by the Application for Payment, less the aggregate of previous payments made by the Owner; and upon Substantial Completion of the entire Work, a sum sufficient to increase the total payments to ninety-five percent (95%) of the Contract Sum, less such amounts as the Owner shall determine for all incomplete Work and unsettled claims as provided in the Contract Documents.

§ 5.1.3 Deleted

§ 5.1.4 Deleted

§ 5.1.5 Deleted

§ 5.1.6 Deleted

(Paragraphs deleted)

§ 5.1.7 Retainage

§ 5.1.7.1 For each progress payment made prior to Substantial Completion of the Work, the Owner may withhold the following amount, as retainage, from the payment otherwise due:

(Insert a percentage or amount to be withheld as retainage from each Application for Payment. The amount of retainage may be limited by governing law.)

The Owner shall withhold five percent (5%) of the dollar value of all work satisfactorily completed until the public work is substantially complete.

§ 5.1.7.1.1 The following items are not subject to retainage:

(Insert any items not subject to the withholding of retainage, such as general conditions, insurance, etc.)

§ 5.1.7.2

(Paragraphs deleted)

Deleted

§ 5.1.7.3

(Paragraphs deleted)

Deleted

§ 5.1.8 Deleted

§ 5.1.9 Except with the Owner's prior approval, the Contractor shall not make advance payments to suppliers for materials or equipment which have not been delivered and stored at the site.

§ 5.2 Final Payment

§ 5.2.1 Final payment, constituting the entire unpaid balance of the Contract Sum, shall be made by the Owner to the Contractor when

- .1 the Contractor has fully performed the Contract except for the Contractor's responsibility to correct Work as provided in Article 12 of modified AIA Document A201-2017, and to satisfy other requirements, if any, which extend beyond final payment; and
- .2 such final payment shall be made by the Owner as follows:

Init.

Final payment by the Owner to the Contractor shall be made sixty-one (61) days after the established Substantial Completion Date, provided that all field work has been completed and all specified documents have been submitted and approved.

§ 5.2.2 Deleted

§ 5.3 Interest

Payments due and unpaid under the Contract shall bear interest from the date payment is due at the rate stated below, or in the absence thereof, at the legal rate prevailing from time to time at the place where the Project is located.
(Insert rate of interest agreed upon, if any.)

%

ARTICLE 6 DISPUTE RESOLUTION

§ 6.1 Initial Decision Maker

The Architect will serve as the Initial Decision Maker pursuant to Article 15 of modified AIA Document A201–2017, unless the parties appoint below another individual, not a party to this Agreement, to serve as the Initial Decision Maker.

(If the parties mutually agree, insert the name, address and other contact information of the Initial Decision Maker, if other than the Architect.)

§ 6.2 Binding Dispute Resolution

For any Claim subject to, but not resolved by, mediation pursuant to Article 15 of modified AIA Document A201–2017, the method of binding dispute resolution shall be as follows:
(Check the appropriate box.)

- Arbitration pursuant to Section 15.4 of AIA Document A201–2017
- Litigation in a court of competent jurisdiction
- Other *(Specify)*

If the Owner and Contractor do not select a method of binding dispute resolution, or do not subsequently agree in writing to a binding dispute resolution method other than litigation, Claims will be resolved by litigation in a court of competent jurisdiction.

ARTICLE 7 TERMINATION OR SUSPENSION

§ 7.1 The Contract may be terminated by the Owner or the Contractor as provided in Article 14 of modified AIA Document A201–2017.

§ 7.1.1 If the Contract is terminated for the Owner’s convenience in accordance with Article 14 of modified AIA Document A201–2017, then the Owner shall pay the Contractor a termination fee as follows:

(Insert the amount of, or method for determining, the fee, if any, payable to the Contractor following a termination for the Owner’s convenience.)

§ 7.2 The Work may be suspended by the Owner as provided in Article 14 of modified AIA Document A201–2017.

Init.

ARTICLE 8 MISCELLANEOUS PROVISIONS

§ 8.1 Where reference is made in this Agreement to a provision of modified AIA Document A201–2017 or another Contract Document, the reference refers to that provision as amended or supplemented by other provisions of the Contract Documents.

§ 8.2 The Owner’s representative:
(Name, address, email address, and other information)

James K. Keefe, P.E.
Senior Director, Capital Asset Management
2550 Northwestern Ave., Suite 1100
West Lafayette, IN 47906

§ 8.3 The Contractor’s representative:
(Name, address, email address, and other information)

§ 8.4 Neither the Owner’s nor the Contractor’s representative shall be changed without ten days’ prior notice to the other party.

§ 8.5 Insurance and Bonds

§ 8.5.1 The Owner and the Contractor shall purchase and maintain insurance as set forth in modified AIA Document A101™–2017, Standard Form of Agreement Between Owner and Contractor where the basis of payment is a Stipulated Sum, Exhibit A, Insurance and Bonds, and elsewhere in the Contract Documents.

§ 8.5.2 The Contractor shall provide bonds as set forth in modified AIA Document A101™–2017 Exhibit A, and elsewhere in the Contract Documents.

§ 8.6 Notice in electronic format, pursuant to Article 1 of modified AIA Document A201–2017, may be given in accordance with AIA Document E203™–2013, Building Information Modeling and Digital Data Exhibit, if completed, or as otherwise set forth below:

(If other than in accordance with AIA Document E203–2013, insert requirements for delivering notice in electronic format such as name, title, and email address of the recipient and whether and how the system will be required to generate a read receipt for the transmission.)

§ 8.7 Other provisions:

ARTICLE 9 ENUMERATION OF CONTRACT DOCUMENTS

§ 9.1 This Agreement is comprised of the following documents:

- .1 AIA Document A101™–2017, Standard Form of Agreement Between Owner and Contractor, as modified
- .2 AIA Document A101™–2017, Exhibit A, Insurance and Bonds, as modified
- .3 AIA Document A201™–2017, General Conditions of the Contract for Construction, as modified
- .4

(Paragraphs deleted)

- Deleted
- .5 Drawings

Init.

/

Number	Title	Date
.6	Specifications	

Section	Title	Date	Pages
---------	-------	------	-------

.7 Addenda, if any:

Number	Date	Pages
--------	------	-------

Portions of Addenda relating to bidding or proposal requirements are not part of the Contract Documents unless the bidding or proposal requirements are also enumerated in this Article 9.

.8 Other Exhibits:
(Check all boxes that apply and include appropriate information identifying the exhibit where required.)

AIA Document E204™-2017, Sustainable Projects Exhibit, dated as indicated below:
(Insert the date of the E204-2017 incorporated into this Agreement.)

The Sustainability Plan:

Title	Date	Pages
-------	------	-------

Supplementary and other Conditions of the Contract:

Document	Title	Date	Pages
----------	-------	------	-------

.9 Other documents, if any, listed below:

(List here any additional documents that are intended to form part of the Contract Documents. AIA Document A201™-2017, as modified, provides that the advertisement or invitation to bid, Instructions to Bidders, sample forms, the Contractor's bid or proposal, portions of Addenda relating to bidding or proposal requirements, and other information furnished by the Owner in anticipation of receiving bids or proposals, are not part of the Contract Documents unless enumerated in this Agreement. Any such documents should be listed here only if intended to be part of the Contract Documents.)

This Agreement entered into as of the day and year first written above.

The Trustees of Purdue University

OWNER *(Signature)*

Jason S. Wasson
 Vice President for Physical Facilities and
 Chief Public Safety Officer

CONTRACTOR *(Signature)*

(Row deleted)

Init.

/



AIA® Document A101® – 2017 Exhibit A

Insurance and Bonds

This Insurance and Bonds Exhibit is part of the Agreement, between the Owner and the Contractor, dated _____.

for the following **PROJECT**:
(Name and location or address)

THE OWNER:
(Name, legal status and address)

The Trustees of Purdue University
2550 Northwestern Ave., Suite 1100
West Lafayette, IN 47906

THE CONTRACTOR:
(Name, legal status and address)

TABLE OF ARTICLES

- A.1 GENERAL
- A.2 OWNER'S INSURANCE
- A.3 CONTRACTOR'S INSURANCE AND BONDS
- A.4 SPECIAL TERMS AND CONDITIONS

ARTICLE A.1 GENERAL

The Owner and Contractor shall purchase and maintain insurance, and provide bonds, as set forth in this Exhibit. As used in this Exhibit, the term General Conditions refers to modified AIA Document A201™–2017, General Conditions of the Contract for Construction.

ARTICLE A.2 OWNER'S INSURANCE

§ A.2.1 General

Prior to commencement of the Work, the Owner shall secure the insurance, and provide evidence of the coverage, required under this Article A.2 and, upon the Contractor's request, provide a Certificate of Insurance evidencing coverage required under Article A.2.

§ A.2.2 Liability Insurance

The Owner shall be responsible for purchasing and maintaining the Owner's usual general liability insurance.

ADDITIONS AND DELETIONS:

The author of this document has added information needed for its completion. The author may also have revised the text of the original AIA standard form. An *Additions and Deletions Report* that notes added information as well as revisions to the standard form text is available from the author and should be reviewed. A vertical line in the left margin of this document indicates where the author has added necessary information and where the author has added to or deleted from the original AIA text.

This document has important legal consequences. Consultation with an attorney is encouraged with respect to its completion or modification.

This document is intended to be used in conjunction with AIA Document A201®–2017, General Conditions of the Contract for Construction. Article 11 of A201®–2017 contains additional insurance provisions.

§ A.2.3 Required Property Insurance

§ A.2.3.1 Unless this obligation is placed on the Contractor pursuant to Section A.3.3.2.1, the Owner shall purchase and maintain, from an insurance company or insurance companies lawfully authorized to issue insurance in the jurisdiction where the Project is located, property insurance written on a builder's risk broad-risk or equivalent policy form and sufficient to cover the total value of the entire Project on a replacement cost basis. The Owner's property insurance coverage shall be no less than the amount of the initial Contract Sum, plus the value of subsequent Modifications and labor performed and materials or equipment supplied by others. The property insurance shall be maintained until Substantial Completion and thereafter as provided in Section A.2.3.1.3, unless otherwise provided in the Contract Documents or otherwise agreed in writing by the parties to this Agreement. This insurance shall include the interests of the Owner, Contractor, Subcontractors, and Sub-subcontractors in the Project.

§ A.2.3.1.1 **Causes of Loss.** The insurance required by this Section A.2.3.1 shall provide coverage for direct physical loss or damage, and shall not exclude the risks of fire, explosion, theft, vandalism, malicious mischief, collapse, earthquake, flood, or windstorm.

(Paragraphs deleted)

(Table deleted)

§ A.2.3.1.2

(Paragraphs deleted)

Deleted

(Table deleted)

§ A.2.3.1.3 Unless the parties agree otherwise, upon Substantial Completion, the Owner shall continue the insurance required by Section A.2.3.1 or, if necessary, replace the insurance policy required under Section A.2.3.1 with property insurance written for the total value of the Project that shall remain in effect until expiration of the period for correction of the Work set forth in Section 12.2.2 of the General Conditions.

§ A.2.3.1.4 **Deductibles and Self-Insured Retentions.** Owner shall be responsible for all losses with the Owner's selected retention or deductible, excepting that the Contractor shall be responsible for the first \$25,000 of each and every property loss.

§ A.2.3.2 **Occupancy or Use Prior to Substantial Completion.** The Owner and the Contractor shall take no action with respect to partial occupancy or use that would cause cancellation, lapse, or reduction of insurance, unless they agree otherwise in writing.

§ A.2.3.3 Insurance for Existing Structures

If the Work involves remodeling an existing structure or constructing an addition to an existing structure, the Owner shall purchase and maintain, until the expiration of the period for correction of Work as set forth in Section 12.2.2 of the General Conditions, broad-risk property insurance, on a replacement cost basis, protecting the existing structure against direct physical loss or damage from the causes of loss identified in Section A.2.3.1, notwithstanding the undertaking of the Work. The Owner shall be responsible for all co-insurance penalties.

§ A.2.4

(Paragraphs deleted)

Deleted

(Paragraphs deleted)

§ A.2.5 Deleted

(Paragraphs deleted)

ARTICLE A.3 CONTRACTOR'S INSURANCE AND BONDS

§ A.3.1 General

§ A.3.1.1 **Certificates of Insurance.** The Contractor shall provide certificates of insurance acceptable to the Owner evidencing compliance with the requirements in this Article A.3 at the following times: (1) prior to commencement of the Work; (2) upon renewal or replacement of each required policy of insurance; and (3) upon the Owner's written request. An additional certificate evidencing continuation of commercial liability coverage, including coverage for completed operations, shall be submitted with the final Application for Payment and thereafter upon renewal or

replacement of such coverage until the expiration of the periods required by Section A.3.2.1 and Section A.3.3.1. The certificates will show the Owner as an additional insured on the Contractor's Commercial General Liability and excess or umbrella liability policy or policies.

§ A.3.1.2 Deductibles and Self-Insured Retentions. The Contractor shall disclose to the Owner any deductible or self-insured retentions applicable to any insurance required to be provided by the Contractor.

§ A.3.1.3 Additional Insured Obligations. To the fullest extent permitted by law, the Contractor shall cause the commercial general liability coverage to include (1) the Owner, the Architect, and the Architect's consultants as additional insureds for claims caused in whole or in part by the Contractor's negligent acts or omissions during the Contractor's operations; and (2) the Owner as an additional insured for claims caused in whole or in part by the Contractor's negligent acts or omissions for which loss occurs during completed operations. The additional insured coverage shall be primary and non-contributory to any of the Owner's general liability insurance policies and shall apply to both ongoing and completed operations. To the extent commercially available, the additional insured coverage shall be no less than that provided by Insurance Services Office, Inc. (ISO) forms CG 20 10 07 04, CG 20 37 07 04, and, with respect to the Architect and the Architect's consultants, CG 20 32 07 04.

§ A.3.1.4 Owner shall not be liable to any person for the failure of Contractor or any Subcontractor to carry any insurance specified or to furnish proof of such coverage to Owner.

§ A.3.2 Contractor's Required Insurance Coverage

§ A.3.2.1 The Contractor shall purchase and maintain the following types and limits of insurance from an insurance company or insurance companies lawfully authorized to issue insurance in the jurisdiction where the Project is located. The Contractor shall maintain the required insurance until the expiration of the period for correction of Work as set forth in Section 12.2.2 of the General Conditions, unless a different duration is stated below:

(If the Contractor is required to maintain insurance for a duration other than the expiration of the period for correction of Work, state the duration.)

§ A.3.2.2 Commercial General Liability

§ A.3.2.2.1 Commercial General Liability insurance for the Project written on an occurrence form with policy limits as determined by Contract Sum:

- Up to \$9,999,999
 - Each Occurrence \$2,000,000 annual aggregate \$2,000,000
- from \$10,000,000 to \$19,999,999
 - Each Occurrence \$3,000,000 annual aggregate \$3,000,000
- from \$20,000,000 to \$40,000,000
 - Each Occurrence \$4,000,000 annual aggregate \$4,000,000
- over \$40,000,000
 - Each Occurrence \$10,000,000 annual aggregate \$10,000,000

for products-completed operations hazard, providing coverage for claims including

- .1 damages because of bodily injury, sickness or disease, including occupational sickness or disease, and death of any person;
- .2 personal injury and advertising injury;
- .3 damages because of physical damage to or destruction of tangible property, including the loss of use of such property;
- .4 bodily injury or property damage arising out of completed operations; and
- .5 the Contractor's indemnity obligations under Section 3.18 of the General Conditions.

§ A.3.2.2.2 The Contractor's Commercial General Liability policy under this Section A.3.2.2 shall not contain an exclusion or restriction of coverage for the following:

- .1 Claims by one insured against another insured, if the exclusion or restriction is based solely on the fact that the claimant is an insured, and there would otherwise be coverage for the claim.

Init.

AIA Document A101® – 2017 Exhibit A. Copyright © 2017 by The American Institute of Architects. All rights reserved. The "American Institute of Architects," "AIA," the AIA Logo, "A101," and "AIA Contract Documents" are registered trademarks and may not be used without permission. This document was produced by AIA software at 13:17:52 ET on 05/21/2021 under Order No.5027455636 which expires on 07/12/2021, is not for resale, is licensed for one-time use only, and may only be used in accordance with the AIA Contract Documents® Terms of Service. To report copyright violations, e-mail copyright@aia.org.

User Notes:

(1782082899)

- .2 Claims for property damage to the Contractor's Work arising out of the products-completed operations hazard where the damaged Work or the Work out of which the damage arises was performed by a Subcontractor.
- .3 Claims for bodily injury other than to employees of the insured.
- .4 Claims for indemnity under Section 3.18 of the General Conditions arising out of injury to employees of the insured.
- .5 Claims or loss excluded under a prior work endorsement or other similar exclusionary language.
- .6 Claims or loss due to physical damage under a prior injury endorsement or similar exclusionary language.
- .7 Claims related to residential, multi-family, or other habitational projects, if the Work is to be performed on such a project.
- .8 Claims related to roofing, if the Work involves roofing.
- .9 Claims related to exterior insulation finish systems (EIFS), synthetic stucco or similar exterior coatings or surfaces, if the Work involves such coatings or surfaces.
- .10 Claims related to earth subsidence or movement, where the Work involves such hazards.
- .11 Claims related to explosion, collapse and underground hazards, where the Work involves such hazards.

§ A.3.2.3 Automobile Liability covering vehicles owned, and non-owned vehicles used, by the Contractor, with policy limits of not less than One Million Dollars (\$1,000,000.00) per accident, for bodily injury, death of any person, and property damage arising out of the ownership, maintenance and use of those motor vehicles along with any other statutorily required automobile coverage.

§ A.3.2.4 The Contractor may achieve the required limits and coverage for Commercial General Liability and Automobile Liability through a combination of primary and excess or umbrella liability insurance, provided such primary and excess or umbrella insurance policies result in the same or greater coverage as the coverages required under Section A.3.2.2 and A.3.2.3, and in no event shall any excess or umbrella liability insurance provide narrower coverage than the primary policy. The excess policy shall not require the exhaustion of the underlying limits only through the actual payment by the underlying insurers.

§ A.3.2.5 Workers' Compensation at statutory limits.

§ A.3.2.6 Employers' Liability with policy limits not less than Five Hundred Thousand Dollars (\$500,000.00) each accident, Five Hundred Thousand Dollars (\$500,000.00) each employee, and Five Hundred Thousand Dollars (\$500,000.00) policy limit.

§ A.3.2.7 Deleted

§ A.3.2.8 If the Contractor is required to furnish professional services as part of the Work, the Contractor shall procure Professional Liability insurance covering performance of the professional services, with policy limits as determined by Contract Sum:

Up to \$9,999,999

- Each Occurrence \$2,000,000 annual aggregate \$2,000,000 from \$10,000,000 to \$19,999,999

- Each Occurrence \$3,000,000 annual aggregate \$3,000,000 from \$20,000,000 to \$40,000,000

- Each Occurrence \$4,000,000 annual aggregate \$4,000,000 over \$40,000,000

- Each Occurrence \$10,000,000 annual aggregate \$10,000,000

§ A.3.2.9 If the Work involves the transport, dissemination, use, or release of pollutants, the Contractor shall procure Pollution Liability insurance, with policy limits of not less than One Million Dollars (\$1,000,000.00) per claim and One Million Dollars (\$1,000,000.00) in the aggregate.

§ A.3.2.10 Coverage under Sections A.3.2.8 and A.3.2.9 may be procured through a Combined Professional Liability and Pollution Liability insurance policy, with combined policy limits of not less than One Million Dollars (\$1,000,000.00) per claim and One Million Dollars (\$1,000,000.00) in the aggregate.

Init.

AIA Document A101® – 2017 Exhibit A. Copyright © 2017 by The American Institute of Architects. All rights reserved. The "American Institute of Architects," "AIA," the AIA Logo, "A101," and "AIA Contract Documents" are registered trademarks and may not be used without permission. This document was produced by AIA software at 13:17:52 ET on 05/21/2021 under Order No.5027455636 which expires on 07/12/2021, is not for resale, is licensed for one-time use only, and may only be used in accordance with the AIA Contract Documents® Terms of Service. To report copyright violations, e-mail copyright@aia.org.

User Notes:

(1782082899)

§ A.3.2.11 Deleted

§ A.3.2.12 Deleted

§ A.3.3 Contractor's Other Insurance Coverage

§ A.3.3.1 Insurance selected and described in this Section A.3.3 shall be purchased from an insurance company or insurance companies lawfully authorized to issue insurance in the jurisdiction where the Project is located; having an A.M. Best rating of "A" VII or better; and acceptable to Owner. The Contractor shall maintain the required insurance until the expiration of the period for correction of Work as set forth in Section 12.2.2 of the General Conditions, unless a different duration is stated below:

(If the Contractor is required to maintain any of the types of insurance selected below for a duration other than the expiration of the period for correction of Work, state the duration.)

§ A.3.3.2 The Contractor shall purchase and maintain the following types and limits of insurance in accordance with Section A.3.3.1.

(Select the types of insurance the Contractor is required to purchase and maintain by placing an X in the box(es) next to the description(s) of selected insurance. Where policy limits are provided, include the policy limit in the appropriate fill point.)

§ A.3.3.2.1 Property insurance of the same type and scope satisfying the requirements identified in Section A.2.3.1, which, if selected in this section A.3.3.2.1, relieves the Owner of the responsibility to purchase and maintain such insurance except insurance required by Section A.2.3.1.3 and Section A.2.3.3. The Contractor shall comply with all obligations of the Owner under Section A.2.3.1 except to the extent provided below. Upon request, the Contractor shall provide the Owner with a copy of the property insurance policy or policies required. The Owner shall be listed as an additional loss payee on said property insurance policy and shall adjust and settle the loss with the insurer and be the trustee of the proceeds of the property insurance in accordance with Article 11 of the General Conditions unless otherwise set forth below:

(Where the Contractor's obligation to provide property insurance differs from the Owner's obligations as described under Section A.2.3, indicate such differences in the space below. Additionally, if a party other than the Owner will be responsible for adjusting and settling a loss with the insurer and acting as the trustee of the proceeds of property insurance in accordance with Article 11 of the General Conditions, indicate the responsible party below.)

§ A.3.3.2.2 **Railroad Protective Liability Insurance**, with policy limits of not less than (\$) per claim and (\$) in the aggregate, for Work within fifty (50) feet of railroad property.

§ A.3.3.2.3 **Asbestos Abatement Liability Insurance**, with policy limits of not less than (\$) per claim and (\$) in the aggregate, for liability arising from the encapsulation, removal, handling, storage, transportation, and disposal of asbestos-containing materials.

§ A.3.3.2.4 Insurance for physical damage to property while it is in storage and in transit to the construction site on a "broad-risks" form.

§ A.3.3.2.5 Property insurance on a "broad-risks" form, covering property owned by the Contractor and used on the Project, including scaffolding and other equipment.

§ A.3.3.2.6 **Other Insurance**
(List below any other insurance coverage to be provided by the Contractor and any applicable limits.)

§ A.3.4 Performance Bond and Payment Bond

The Contractor shall provide surety bonds, from a company or companies lawfully authorized to issue surety bonds in the jurisdiction where the Project is located, as follows:

§ A.3.4.1 The laws of the State of Indiana (IC § 5-16-5.5-1 et seq.) contain certain special provisions regarding retainage, bonds and payment of Contractors and Subcontractors. Contracts in excess of \$200,000 are governed by those provisions. For purposes of this Contract, the Owner has determined to withhold as statutory retainage no more than 5 percent of the dollar value of the work satisfactorily completed until the work is substantially completed.

§ A.3.4.2 The amounts retained by the Owner from the Contractor pursuant to retainage provisions shall be placed in an escrow account in accordance with a written escrow agreement with a bank or savings and loan institution as escrow agent, selected by mutual agreement between the Contractor and Owner. This escrow agreement shall have no application to payments withheld by the Owner pursuant to provisions of the Construction Contract intended to protect the Owner from loss on account of: Defective work not remedied; claims filed on reasonable evidence; failure of the Contractor to make payments when due to Subcontractors; or for material or labor; reasonable doubt that the Contract can be completed for the balance then unpaid; damage to another Contractor; failure or refusal of the Contractor to prosecute the work in strict compliance with the Contractor's construction schedule for the work; or similar provisions.

§ A.3.4.3 Contractor shall comply with all applicable provisions of I.C. § 5-16-5-1 with respect to its Subcontractors (as the term "Subcontractor" is defined therein).

(Table deleted)

§ A.3.4.4 Contractor shall furnish Owner with a performance bond and a payment bond in the form, manner and amount required by the Instructions to Bidders.

§ A.3.4.5 Upon the request of any person or entity appearing to be a potential beneficiary of bonds covering payment of obligations arising under the Contract, the Contractor shall promptly furnish a copy of the bonds or shall authorize a copy to be furnished.

ARTICLE A.4 SPECIAL TERMS AND CONDITIONS

Special terms and conditions that modify this Insurance and Bonds Exhibit, if any, are as follows:

CERTIFICATE OF INSURANCE

ACORD™ CERTIFICATE OF LIABILITY INSURANCE		DATE (MM/DD/YYYY)
PRODUCER	THIS CERTIFICATE IS ISSUED AS A MATTER OF INFORMATION ONLY AND CONFERS NO RIGHTS UPON THE CERTIFICATE HOLDER. THIS CERTIFICATE DOES NOT AMEND, EXTEND OR ALTER THE COVERAGE AFFORDED BY THE POLICIES BELOW.	
INSURED	INSURERS AFFORDING COVERAGE	NAIC #
	INSURER A: Purdue University Insurance Services Enterprise	
	INSURER B:	
	INSURER C:	
	INSURER D:	
	INSURER E:	

COVERAGES

THE POLICIES OF INSURANCE LISTED BELOW HAVE BEEN ISSUED TO THE INSURED NAMED ABOVE FOR THE POLICY PERIOD INDICATED. NOTWITHSTANDING ANY REQUIREMENT, TERM OR CONDITION OF ANY CONTRACT OR OTHER DOCUMENT WITH RESPECT TO WHICH THIS CERTIFICATE MAY BE ISSUED OR MAY PERTAIN, THE INSURANCE AFFORDED BY THE POLICIES DESCRIBED HEREIN IS SUBJECT TO ALL THE TERMS, EXCLUSIONS AND CONDITIONS OF SUCH POLICIES. AGGREGATE LIMITS SHOWN MAY HAVE BEEN REDUCED BY PAID CLAIMS.

INSR LTR	ADDL INSR	TYPE OF INSURANCE	POLICY NUMBER	POLICY EFFECTIVE DATE (MM/DD/YY)	POLICY EXPIRATION DATE (MM/DD/YY)	LIMITS
		GENERAL LIABILITY <input type="checkbox"/> COMMERCIAL GENERAL LIABILITY <input type="checkbox"/> CLAIMS MADE <input type="checkbox"/> OCCUR GEN'L AGGREGATE LIMIT APPLIES PER: <input type="checkbox"/> POLICY <input type="checkbox"/> OBJECT <input type="checkbox"/> LOC				EACH OCCURRENCE \$ LIMITED TO RENTED PREMISES (Ea occurrence) \$ MEDICAL (Any one person) \$ PERSONAL & ADV INJURY \$ GENERAL AGGREGATE \$ PRODUCTS - COMPIOP AGG \$
		AUTOMOBILE LIABILITY <input type="checkbox"/> ANY AUTO <input type="checkbox"/> ALL OWNED AUTOS <input type="checkbox"/> SCHEDULED AUTOS <input type="checkbox"/> HIRED AUTOS <input type="checkbox"/> NON-OWNED AUTOS				UNINSURED SINGLE LIMIT (Ea accident) \$ BODILY INJURY (Per person) \$ BODILY INJURY (Per accident) \$ PROPERTY DAMAGE (Per accident) \$
		GARAGE LIABILITY <input type="checkbox"/> ANY AUTO				AUTO ONLY - EA ACCIDENT \$ OTHER THAN AUTO ONLY: EAACC \$ AGG \$
		EXCESS/UMBRELLA LIABILITY <input type="checkbox"/> OCCUR <input type="checkbox"/> CLAIMS MADE <input type="checkbox"/> DEDUCTIBLE <input type="checkbox"/> RETENTION \$				EACH OCCURRENCE \$ AGGREGATE \$ \$ \$
		WORKERS COMPENSATION AND EMPLOYERS' LIABILITY ANY PROPRIETOR/PARTNER/EXECUTIVE OFFICER/MEMBER EXCLUDED? If yes, describe under SPECIAL PROVISIONS below				WC STATUTORY LIMITS OTHER E.L. EACH ACCIDENT \$ E.L. DISEASE - EA EMPLOYEE \$ E.L. DISEASE - POLICY LIMIT \$
		OTHER				

REFERENCE COPY ONLY

USE CURRENT EDITION

DESCRIPTION OF OPERATIONS / LOCATIONS / VEHICLES / EXCLUSIONS ADDED BY ENDORSEMENT / SPECIAL PROVISIONS

CERTIFICATE HOLDER 	CANCELLATION SHOULD ANY OF THE ABOVE DESCRIBED POLICIES BE CANCELLED BEFORE THE EXPIRATION DATE THEREOF, THE ISSUING INSURER WILL ENDEAVOR TO MAIL <u>30</u> DAYS WRITTEN NOTICE TO THE CERTIFICATE HOLDER NAMED TO THE LEFT, BUT FAILURE TO DO SO SHALL IMPOSE NO OBLIGATION OR LIABILITY OF ANY KIND UPON THE INSURER, ITS AGENTS OR REPRESENTATIVES. AUTHORIZED REPRESENTATIVE
-----------------------------------	--

CONTRACT CHANGE ORDER

Purdue University

Physical Facilities Construction Department
401 S. Grant Street
West Lafayette, IN 47907-2024

Phone (765) 494-0580
Fax (765) 494-0918

TITLE: _____ **DATE:** _____
PROJECT: _____ **CONTRACT NO:** _____
TO: _____ **WBSE:** _____
FUND: _____
FUNDS COMMITMENT: _____

You are hereby requested to proceed with the following changes from the contract plans and specifications:

RE:

PP90/PCO #:

REFERENCE COPY ONLY

The Original Contract Sum was

Net Change by Previously Authorized Requests and Changes

The Contract Sum Will be Decreased

The Contract Time Will be Decreased

This document shall become an amendment to the contract and all provisions of the contract shall apply hereto. In consideration of the change order agreed to herein as complete equitable adjustment, the Contractor hereby releases the Owner of and from any and all cost, expenses, damages, or claims attributable in whole or in part to (1) the facts and circumstances giving rise to this change order and (2) the execution of this change order.

Recommended by:
ARCHITECT/ENGINEERING FIRM

Approved by:

Executed by:
THE TRUSTEES of PURDUE UNIVERSITY

Signature _____

Signature _____

Signature - FOR THE TREASURER _____

Printed Name _____

Printed Name _____

Printed Name _____

Date _____

Date _____

Date _____

CONSTRUCTION INVOICE VOUCHER

Business Services Form: CIV		Construction Invoice Voucher			Purdue University	
Vendor Number (Firm)		Vendor Number (Escrow)		PU Order Number		
Vendor (Name and Address)				Date		
Name:				Invoice #		
Remit Address:				Amount to Vendor		
City, State, Zip:				Amount to Bank (for Escrow)		
Project Title:				REFERENCE COPY ONLY ORIGINAL FORMS WILL BE SENT TO SUCCESSFUL BIDDERS		
Payment Request Number:						
Original Contract Sum		Change Orders Through No. _____		Total Installed To Date		
Total Additions		Subtotal		Materials Stored		
Total Deductions		Total Contract Amount		Total Installed and Stored		
				Less _____% Retainage		
				Total Earned Less Retainage		
				Less Previous Payments		
				This Payment		
<p>"This is to certify that in the performance of this Contract, neither the undersigned contractor nor (so far as the undersigned has knowledge) any of his subcontractors has violated the provisions of 'Nondiscrimination Provisions' of General Conditions of the Contract".</p> <p>Signed _____</p>						
For Purdue University Use Only:						
G/L Account	Amount	Cost Center	Order	WBS Element	Fund	Earmarked Funds
Held Chk?	Contact for Held Check			Campus	Phone	Audit
Department Head				Date	Dept/Building	Document #/Date
Recommended				Date	Dept/Building	
APPROVED				Date	Dept/Building	

BREAKDOWN OF APPLICATION FOR PAYMENT

Physical Facilities
Form 87, Rev. 1-80

BREAKDOWN OF APPLICATION FOR PAYMENT

PROJECT TITLE : _____
 CONTRACTOR : _____
 DATE OF ESTIMATE : _____ ESTIMATE NO: _____
 FOR PERIOD FROM : _____ TO: _____
 Application is Made For Payment, As Hereinafter Shown, In Connection With The Subject Project.

Item No.	Description of Work	Contract Amount	Materials Stored at Job Site*	Labor/Material Installed This Estimate	Labor/Material Installed To Date	%
<p>REFERENCE COPY ONLY</p>						
Subtotal or Total						

*Submit Itemized List In Accordance With Project Specifications

CONTRACTOR'S AFFIDAVIT, WAIVER OF LIEN, CERTIFICATION AND GUARANTEE

Physical Facilities Form 86
July 22, 2014

CONTRACTOR'S AFFIDAVIT, WAIVER OF LIEN, AND GUARANTEE

TO: _____

Job No: _____

Date: _____

TO WHOM IT MAY CONCERN:

We, the undersigned _____
having been employed by _____ to furnish and/or install

REFERENCE COPY ONLY

for the _____,
do hereby affirm that we have paid all charges against us for labor, materials, equipment, rentals and all other items
of expense under this contract, except as follows: (List all items of expense which you have not paid whether you
have received invoice or not.) _____

Also, we, the undersigned, for and in consideration of payments (\$ _____) made to
_____, the receipt whereof is hereby acknowledged, do
hereby waive and release any and every lien, or claim, or right of lien on said above described building and premises
on account of labor, skill, machinery, or materials, or all, furnished to

by the undersigned for said building or premises.

The undersigned further guarantees that all work is executed in strict accordance with the specifications and
contract drawings, including any changes or alterations authorized in writing, and that should any defect appear
within the periods as specified due to faulty materials or workmanship furnished in the performance of the contract,
for which payment is herein acknowledged, that the said undersigned will, in accordance with the Specifications,
repair and remedy said defects without expense to the Owner or _____
_____ when notified to do so.

Given under our hand and seal this
_____ day of _____, 20 _____

BY: _____

TITLE: _____

Subscribed and sworn to before me this _____ day of _____, 20 _____

State of _____ SS:

County of _____

My Commission Expires: _____

(Notary Public)

E-VERIFY PROGRAM AFFIDAVIT

E-VERIFY PROGRAM AFFIDAVIT

(Submit this affidavit, signed and notarized, seven days after the bid)

Contractor: _____

Project Name: _____

Date: _____

We, the undersigned, do hereby affirm that we are compliant with [IC 5-16-13-11 and 22-5-1.7]. The undersigned further affirms that the Contractor:

1. Has enrolled and is participating in the E-Verify program
2. Does not knowingly employ an unauthorized alien.

Given under our hand and seal this _____ day of _____, 20___.

 By: _____
 Title: _____

STATE OF _____)
) SS:
 COUNTY OF _____)

Subscribed and sworn to before me this _____ day of _____, 20___.

 (Notary Public)

COUNTY OF RESIDENCE

MY COMMISSION EXPIRES

CONTRIBUTION BY TIER 1 CONTRACTOR AFFIDAVIT

CONTRIBUTION BY TIER 1 CONTRACTOR AFFIDAVIT

(Submit this affidavit, signed and notarized, with Contractor's Waiver of Lien)

Contractor: _____

Project Name: _____

Date: _____

REFERENCE COPY ONLY

This is to certify that in the performance of this contract, the tier 1 Contractor contributed in work, material, or services at least fifteen percent (15%) of the awarded contract price in accordance with IC 5-16-13-9.

Given under our hand and seal this
_____ day of _____, 20____.

By: _____

Title: _____

STATE OF _____)
COUNTY OF _____) SS:

Subscribed and sworn to before me this _____ day of _____, 20____.

(Notary Public)

COUNTY OF RESIDENCE

MY COMMISSION EXPIRES



AIA® Document A201® – 2017

General Conditions of the Contract for Construction

for the following PROJECT:
(Name and location or address)

THE OWNER:
(Name, legal status and address)

The Trustees of Purdue University
2550 Northwestern Ave., Suite 1100
West Lafayette, IN 47906

THE ARCHITECT:
(Name, legal status and address)

TABLE OF ARTICLES

- 1 GENERAL PROVISIONS
- 2 OWNER
- 3 CONTRACTOR
- 4 ARCHITECT
- 5 SUBCONTRACTORS
- 6 CONSTRUCTION BY OWNER OR BY SEPARATE CONTRACTORS
- 7 CHANGES IN THE WORK
- 8 TIME
- 9 PAYMENTS AND COMPLETION
- 10 PROTECTION OF PERSONS AND PROPERTY
- 11 INSURANCE AND BONDS
- 12 UNCOVERING AND CORRECTION OF WORK
- 13 MISCELLANEOUS PROVISIONS
- 14 TERMINATION OR SUSPENSION OF THE CONTRACT
- 15 CLAIMS AND DISPUTES

ADDITIONS AND DELETIONS:

The author of this document has added information needed for its completion. The author may also have revised the text of the original AIA standard form. An *Additions and Deletions Report* that notes added information as well as revisions to the standard form text is available from the author and should be reviewed. A vertical line in the left margin of this document indicates where the author has added necessary information and where the author has added to or deleted from the original AIA text.

This document has important legal consequences. Consultation with an attorney is encouraged with respect to its completion or modification.

For guidance in modifying this document to include supplementary conditions, see AIA Document A503™, Guide for Supplementary Conditions.

INDEX

(Topics and numbers in bold are Section headings.)

NOTICE: Substantive changes have been made to these A 201 General Conditions which are not reflected in the Index below.

Acceptance of Nonconforming Work

9.6.6, 9.9.3, **12.3**

Acceptance of Work

9.6.6, 9.8.2, 9.9.3, 9.10.1, 9.10.3, 12.3

Access to Work

3.16, 6.2.1, 12.1

Accident Prevention

10

Acts and Omissions

3.2, 3.3.2, 3.12.8, 3.18, 4.2.3, 8.3.1, 9.5.1, 10.2.5,

10.2.8, 13.3.2, 14.1, 15.1.2, 15.2

Addenda

1.1.1

Additional Costs, Claims for

3.7.4, 3.7.5, 10.3.2, 15.1.5

Additional Inspections and Testing

9.4.2, 9.8.3, 12.2.1, **13.4**

Additional Time, Claims for

3.2.4, 3.7.4, 3.7.5, 3.10.2, 8.3.2, **15.1.6**

Administration of the Contract

3.1.3, **4.2**, 9.4, 9.5

Advertisement or Invitation to Bid

1.1.1

Aesthetic Effect

4.2.13

Allowances

3.8

Applications for Payment

4.2.5, 7.3.9, 9.2, **9.3**, 9.4, 9.5.1, 9.5.4, 9.6.3, 9.7, 9.10

Approvals

2.1.1, 2.3.1, 2.5, 3.1.3, 3.10.2, 3.12.8, 3.12.9,

3.12.10.1, 4.2.7, 9.3.2, 13.4.1

Arbitration

8.3.1, 15.3.2, **15.4**

ARCHITECT

4

Architect, Definition of

4.1.1

Architect, Extent of Authority

2.5, 3.12.7, 4.1.2, 4.2, 5.2, 6.3, 7.1.2, 7.3.4, 7.4, 9.2, 9.3.1, 9.4, 9.5, 9.6.3, 9.8, 9.10.1, 9.10.3, 12.1, 12.2.1, 13.4.1, 13.4.2, 14.2.2, 14.2.4, 15.1.4, 15.2.1

Architect, Limitations of Authority and Responsibility

2.1.1, 3.12.4, 3.12.8, 3.12.10, 4.1.2, 4.2.1, 4.2.2, 4.2.3, 4.2.6, 4.2.7, 4.2.10, 4.2.12, 4.2.13, 5.2.1, 7.4, 9.4.2, 9.5.4, 9.6.4, 15.1.4, 15.2

Architect's Additional Services and Expenses

2.5, 12.2.1, 13.4.2, 13.4.3, 14.2.4

Architect's Administration of the Contract

3.1.3, 3.7.4, 15.2, 9.4.1, 9.5

Architect's Approvals

2.5, 3.1.3, 3.5, 3.10.2, 4.2.7

Architect's Authority to Reject Work

3.5, 4.2.6, 12.1.2, 12.2.1

Architect's Copyright

1.1.7, 1.5

Architect's Decisions

3.7.4, 4.2.6, 4.2.7, 4.2.11, 4.2.12, 4.2.13, 4.2.14, 6.3, 7.3.4, 7.3.9, 8.1.3, 8.3.1, 9.2, 9.4.1, 9.5, 9.8.4, 9.9.1, 13.4.2, 15.2

Architect's Inspections

3.7.4, 4.2.2, 4.2.9, 9.4.2, 9.8.3, 9.9.2, 9.10.1, 13.4

Architect's Instructions

3.2.4, 3.3.1, 4.2.6, 4.2.7, 13.4.2

Architect's Interpretations

4.2.11, 4.2.12

Architect's Project Representative

4.2.10

Architect's Relationship with Contractor

1.1.2, 1.5, 2.3.3, 3.1.3, 3.2.2, 3.2.3, 3.2.4, 3.3.1, 3.4.2, 3.5, 3.7.4, 3.7.5, 3.9.2, 3.9.3, 3.10, 3.11, 3.12, 3.16, 3.18, 4.1.2, 4.2, 5.2, 6.2.2, 7, 8.3.1, 9.2, 9.3, 9.4, 9.5, 9.7, 9.8, 9.9, 10.2.6, 10.3, 11.3, 12, 13.3.2, 13.4, 15.2

Architect's Relationship with Subcontractors

1.1.2, 4.2.3, 4.2.4, 4.2.6, 9.6.3, 9.6.4, 11.3

Architect's Representations

9.4.2, 9.5.1, 9.10.1

Architect's Site Visits

3.7.4, 4.2.2, 4.2.9, 9.4.2, 9.5.1, 9.9.2, 9.10.1, 13.4

Asbestos

10.3.1

Attorneys' Fees

3.18.1, 9.6.8, 9.10.2, 10.3.3

Award of Separate Contracts

6.1.1, 6.1.2

Award of Subcontracts and Other Contracts for Portions of the Work

5.2

Basic Definitions

1.1

Bidding Requirements

1.1.1

Binding Dispute Resolution

8.3.1, 9.7, 11.5, 13.1, 15.1.2, 15.1.3, 15.2.1, 15.2.5, 15.2.6.1, 15.3.1, 15.3.2, 15.3.3, 15.4.1

Bonds, Lien

7.3.4.4, 9.6.8, 9.10.2, 9.10.3

Bonds, Performance, and Payment

7.3.4.4, 9.6.7, 9.10.3, **11.1.2**, 11.1.3, **11.5**

Building Information Models Use and Reliance

1.8

Init.

/

AIA Document A201® – 2017. Copyright © 1911, 1915, 1918, 1925, 1937, 1951, 1958, 1961, 1963, 1966, 1970, 1976, 1987, 1997, 2007 and 2017 by The American Institute of Architects. All rights reserved. The "American Institute of Architects," "AIA," the AIA Logo, "A201," and "AIA Contract Documents" are registered trademarks and may not be used without permission. This document was produced by AIA software at 15:51:23 ET on 04/27/2021 under Order No.5027455636 which expires on 07/12/2021, is not for resale, is licensed for one-time use only, and may only be used in accordance with the AIA Contract Documents® Terms of Service. To report copyright violations, e-mail copyright@aia.org.
User Notes:

(1783516235)

Building Permit

3.7.1

Capitalization

1.3

Certificate of Substantial Completion

9.8.3, 9.8.4, 9.8.5

Certificates for Payment

4.2.1, 4.2.5, 4.2.9, 9.3.3, **9.4**, 9.5, 9.6.1, 9.6.6, 9.7,

9.10.1, 9.10.3, 14.1.1.3, 14.2.4, 15.1.4

Certificates of Inspection, Testing or Approval

13.4.4

Certificates of Insurance

9.10.2

Change Orders

1.1.1, 3.4.2, 3.7.4, 3.8.2.3, 3.11, 3.12.8, 4.2.8, 5.2.3,

7.1.2, 7.1.3, **7.2**, 7.3.2, 7.3.7, 7.3.9, 7.3.10, 8.3.1,

9.3.1.1, 9.10.3, 10.3.2, 11.2, 11.5, 12.1.2

Change Orders, Definition of

7.2.1

CHANGES IN THE WORK

2.2.2, 3.11, 4.2.8, 7, 7.2.1, 7.3.1, 7.4, 8.3.1, 9.3.1.1, 11.5

Claims, Definition of

15.1.1

Claims, Notice of

1.6.2, 15.1.3

CLAIMS AND DISPUTES

3.2.4, 6.1.1, 6.3, 7.3.9, 9.3.3, 9.10.4, 10.3.3, **15**, 15.4

Claims and Timely Assertion of Claims

15.4.1

Claims for Additional Cost

3.2.4, 3.3.1, 3.7.4, 7.3.9, 9.5.2, 10.2.5, 10.3.2, **15.1.5**

Claims for Additional Time

3.2.4, 3.3.1, 3.7.4, 6.1.1, 8.3.2, 9.5.2, 10.3.2, **15.1.6**

Concealed or Unknown Conditions, Claims for

3.7.4

Claims for Damages

3.2.4, 3.18, 8.3.3, 9.5.1, 9.6.7, 10.2.5, 10.3.3, 11.3,

11.3.2, 14.2.4, 15.1.7

Claims Subject to Arbitration

15.4.1

Cleaning Up

3.15, 6.3

Commencement of the Work, Conditions Relating to

2.2.1, 3.2.2, 3.4.1, 3.7.1, 3.10.1, 3.12.6, 5.2.1, 5.2.3,

6.2.2, 8.1.2, 8.2.2, 8.3.1, 11.1, 11.2, **15.1.5**

Commencement of the Work, Definition of

8.1.2

Communications

3.9.1, **4.2.4**

Completion, Conditions Relating to

3.4.1, 3.11, 3.15, 4.2.2, 4.2.9, 8.2, 9.4.2, 9.8, 9.9.1,

9.10, 12.2, 14.1.2, 15.1.2

COMPLETION, PAYMENTS AND

9

Completion, Substantial

3.10.1, 4.2.9, 8.1.1, 8.1.3, 8.2.3, 9.4.2, 9.8, 9.9.1,

9.10.3, 12.2, 15.1.2

Compliance with Laws

2.3.2, 3.2.3, 3.6, 3.7, 3.12.10, 3.13, 9.6.4, 10.2.2, 13.1,

13.3, 13.4.1, 13.4.2, 13.5, 14.1.1, 14.2.1.3, 15.2.8,

15.4.2, 15.4.3

Concealed or Unknown Conditions

3.7.4, 4.2.8, 8.3.1, 10.3

Conditions of the Contract

1.1.1, 6.1.1, 6.1.4

Consent, Written

3.4.2, 3.14.2, 4.1.2, 9.8.5, 9.9.1, 9.10.2, 9.10.3, 13.2,

15.4.4.2

Consolidation or Joinder

15.4.4

CONSTRUCTION BY OWNER OR BY SEPARATE CONTRACTORS

1.1.4, 6

Construction Change Directive, Definition of

7.3.1

Construction Change Directives

1.1.1, 3.4.2, 3.11, 3.12.8, 4.2.8, 7.1.1, 7.1.2, 7.1.3, **7.3**,

9.3.1.1

Construction Schedules, Contractor's

3.10, 3.11, 3.12.1, 3.12.2, 6.1.3, 15.1.6.2

Contingent Assignment of Subcontracts

5.4, 14.2.2.2

Continuing Contract Performance

15.1.4

Contract, Definition of

1.1.2

CONTRACT, TERMINATION OR SUSPENSION OF THE

5.4.1.1, 5.4.2, 11.5, **14**

Contract Administration

3.1.3, 4, 9.4, 9.5

Contract Award and Execution, Conditions Relating to

3.7.1, 3.10, 5.2, 6.1

Contract Documents, Copies Furnished and Use of

1.5.2, 2.3.6, 5.3

Contract Documents, Definition of

1.1.1

Contract Sum

2.2.2, 2.2.4, 3.7.4, 3.7.5, 3.8, 3.10.2, 5.2.3, 7.3, 7.4,

9.1, 9.2, 9.4.2, 9.5.1.4, 9.6.7, 9.7, 10.3.2, 11.5, 12.1.2,

12.3, 14.2.4, 14.3.2, 15.1.4.2, **15.1.5**, **15.2.5**

Contract Sum, Definition of

9.1

Contract Time

1.1.4, 2.2.1, 2.2.2, 3.7.4, 3.7.5, 3.10.2, 5.2.3, 6.1.5,

7.2.1.3, 7.3.1, 7.3.5, 7.3.6, 7, 7, 7.3.10, 7.4, 8.1.1,

8.2.1, 8.2.3, 8.3.1, 9.5.1, 9.7, 10.3.2, 12.1.1, 12.1.2,

14.3.2, 15.1.4.2, 15.1.6.1, 15.2.5

Contract Time, Definition of

8.1.1

Init.

/

CONTRACTOR

3

Contractor, Definition of

3.1, 6.1.2

Contractor's Construction and Submittal Schedules

3.10, 3.12.1, 3.12.2, 4.2.3, 6.1.3, 15.1.6.2

Contractor's Employees

2.2.4, 3.3.2, 3.4.3, 3.8.1, 3.9, 3.18.2, 4.2.3, 4.2.6, 10.2, 10.3, 11.3, 14.1, 14.2.1.1

Contractor's Liability Insurance

11.1

Contractor's Relationship with Separate Contractors and Owner's Forces

3.12.5, 3.14.2, 4.2.4, 6, 11.3, 12.2.4

Contractor's Relationship with Subcontractors

1.2.2, 2.2.4, 3.3.2, 3.18.1, 3.18.2, 4.2.4, 5, 9.6.2, 9.6.7, 9.10.2, 11.2, 11.3, 11.4

Contractor's Relationship with the Architect

1.1.2, 1.5, 2.3.3, 3.1.3, 3.2.2, 3.2.3, 3.2.4, 3.3.1, 3.4.2, 3.5.1, 3.7.4, 3.10, 3.11, 3.12, 3.16, 3.18, 4.2, 5.2, 6.2.2, 7, 8.3.1, 9.2, 9.3, 9.4, 9.5, 9.7, 9.8, 9.9, 10.2.6, 10.3, 11.3, 12, 13.4, 15.1.3, 15.2.1

Contractor's Representations

3.2.1, 3.2.2, 3.5, 3.12.6, 6.2.2, 8.2.1, 9.3.3, 9.8.2

Contractor's Responsibility for Those Performing the Work

3.3.2, 3.18, 5.3, 6.1.3, 6.2, 9.5.1, 10.2.8

Contractor's Review of Contract Documents

3.2

Contractor's Right to Stop the Work

2.2.2, 9.7

Contractor's Right to Terminate the Contract

14.1

Contractor's Submittals

3.10, 3.11, 3.12, 4.2.7, 5.2.1, 5.2.3, 9.2, 9.3, 9.8.2, 9.8.3, 9.9.1, 9.10.2, 9.10.3

Contractor's Superintendent

3.9, 10.2.6

Contractor's Supervision and Construction

Procedures

1.2.2, 3.3, 3.4, 3.12.10, 4.2.2, 4.2.7, 6.1.3, 6.2.4, 7.1.3, 7.3.4, 7.3.6, 8.2, 10, 12, 14, 15.1.4

Coordination and Correlation

1.2, 3.2.1, 3.3.1, 3.10, 3.12.6, 6.1.3, 6.2.1

Copies Furnished of Drawings and Specifications

1.5, 2.3.6, 3.11

Copyrights

1.5, 3.17

Correction of Work

2.5, 3.7.3, 9.4.2, 9.8.2, 9.8.3, 9.9.1, 12.1.2, 12.2, 12.3, 15.1.3.1, 15.1.3.2, 15.2.1

Correlation and Intent of the Contract Documents

1.2

Cost, Definition of

7.3.4

Costs

2.5, 3.2.4, 3.7.3, 3.8.2, 3.15.2, 5.4.2, 6.1.1, 6.2.3, 7.3.3.3, 7.3.4, 7.3.8, 7.3.9, 9.10.2, 10.3.2, 10.3.6, 11.2, 12.1.2, 12.2.1, 12.2.4, 13.4, 14

Cutting and Patching

3.14, 6.2.5

Damage to Construction of Owner or Separate Contractors

3.14.2, 6.2.4, 10.2.1.2, 10.2.5, 10.4, 12.2.4

Damage to the Work

3.14.2, 9.9.1, 10.2.1.2, 10.2.5, 10.4, 12.2.4

Damages, Claims for

3.2.4, 3.18, 6.1.1, 8.3.3, 9.5.1, 9.6.7, 10.3.3, 11.3.2, 11.3, 14.2.4, 15.1.7

Damages for Delay

6.2.3, 8.3.3, 9.5.1.6, 9.7, 10.3.2, 14.3.2

Date of Commencement of the Work, Definition of

8.1.2

Date of Substantial Completion, Definition of

8.1.3

Day, Definition of

8.1.4

Decisions of the Architect

3.7.4, 4.2.6, 4.2.7, 4.2.11, 4.2.12, 4.2.13, 6.3, 7.3.4, 7.3.9, 8.1.3, 8.3.1, 9.2, 9.4, 9.5.1, 9.8.4, 9.9.1, 13.4.2, 14.2.2, 14.2.4, 15.1, 15.2

Decisions to Withhold Certification

9.4.1, 9.5, 9.7, 14.1.1.3

Defective or Nonconforming Work, Acceptance, Rejection and Correction of

2.5, 3.5, 4.2.6, 6.2.3, 9.5.1, 9.5.3, 9.6.6, 9.8.2, 9.9.3, 9.10.4, 12.2.1

Definitions

1.1, 2.1.1, 3.1.1, 3.5, 3.12.1, 3.12.2, 3.12.3, 4.1.1, 5.1, 6.1.2, 7.2.1, 7.3.1, 8.1, 9.1, 9.8.1, 15.1.1

Delays and Extensions of Time

3.2, 3.7.4, 5.2.3, 7.2.1, 7.3.1, 7.4, 8.3, 9.5.1, 9.7, 10.3.2, 10.4, 14.3.2, 15.1.6, 15.2.5

Digital Data Use and Transmission

1.7

Disputes

6.3, 7.3.9, 15.1, 15.2

Documents and Samples at the Site

3.11

Drawings, Definition of

1.1.5

Drawings and Specifications, Use and Ownership of

3.11

Effective Date of Insurance

8.2.2

Emergencies

10.4, 14.1.1.2, 15.1.5

Employees, Contractor's

3.3.2, 3.4.3, 3.8.1, 3.9, 3.18.2, 4.2.3, 4.2.6, 10.2, 10.3.3, 11.3, 14.1, 14.2.1.1

Equipment, Labor, or Materials
1.1.3, 1.1.6, 3.4, 3.5, 3.8.2, 3.8.3, 3.12, 3.13, 3.15.1,
4.2.6, 4.2.7, 5.2.1, 6.2.1, 7.3.4, 9.3.2, 9.3.3, 9.5.1.3,
9.10.2, 10.2.1, 10.2.4, 14.2.1.1, 14.2.1.2
Execution and Progress of the Work
1.1.3, 1.2.1, 1.2.2, 2.3.4, 2.3.6, 3.1, 3.3.1, 3.4.1, 3.7.1,
3.10.1, 3.12, 3.14, 4.2, 6.2.2, 7.1.3, 7.3.6, 8.2, 9.5.1,
9.9.1, 10.2, 10.3, 12.1, 12.2, 14.2, 14.3.1, 15.1.4
Extensions of Time
3.2.4, 3.7.4, 5.2.3, 7.2.1, 7.3, 7.4, 9.5.1, 9.7, 10.3.2,
10.4, 14.3, 15.1.6, **15.2.5**

Failure of Payment

9.5.1.3, **9.7**, 9.10.2, 13.5, 14.1.1.3, 14.2.1.2

Faulty Work

(See Defective or Nonconforming Work)

Final Completion and Final Payment

4.2.1, 4.2.9, 9.8.2, **9.10**, 12.3, 14.2.4, 14.4.3

Financial Arrangements, Owner's

2.2.1, 13.2.2, 14.1.1.4

GENERAL PROVISIONS

1

Governing Law

13.1

Guarantees (See Warranty)

Hazardous Materials and Substances

10.2.4, 10.3

Identification of Subcontractors and Suppliers

5.2.1

Indemnification

3.17, **3.18**, 9.6.8, 9.10.2, 10.3.3, 11.3

Information and Services Required of the Owner

2.1.2, **2.2**, 2.3, 3.2.2, 3.12.10.1, 6.1.3, 6.1.4, 6.2.5,

9.6.1, 9.9.2, 9.10.3, 10.3.3, 11.2, 13.4.1, 13.4.2,

14.1.1.4, 14.1.4, 15.1.4

Initial Decision

15.2

Initial Decision Maker, Definition of

1.1.8

Initial Decision Maker, Decisions

14.2.4, 15.1.4.2, 15.2.1, 15.2.2, 15.2.3, 15.2.4, 15.2.5

Initial Decision Maker, Extent of Authority

14.2.4, 15.1.4.2, 15.2.1, 15.2.2, 15.2.3, 15.2.4, 15.2.5

Injury or Damage to Person or Property

10.2.8, 10.4

Inspections

3.1.3, 3.3.3, 3.7.1, 4.2.2, 4.2.6, 4.2.9, 9.4.2, 9.8.3,

9.9.2, 9.10.1, 12.2.1, 13.4

Instructions to Bidders

1.1.1

Instructions to the Contractor

3.2.4, 3.3.1, 3.8.1, 5.2.1, 7, 8.2.2, 12, 13.4.2

Instruments of Service, Definition of

1.1.7

Insurance

6.1.1, 7.3.4, 8.2.2, 9.3.2, 9.8.4, 9.9.1, 9.10.2, 10.2.5, **11**

Insurance, Notice of Cancellation or Expiration

11.1.4, 11.2.3

Insurance, Contractor's Liability

11.1

Insurance, Effective Date of

8.2.2, 14.4.2

Insurance, Owner's Liability

11.2

Insurance, Property

10.2.5, 11.2, 11.4, 11.5

Insurance, Stored Materials

9.3.2

INSURANCE AND BONDS

11

Insurance Companies, Consent to Partial Occupancy

9.9.1

Insured loss, Adjustment and Settlement of

11.5

Intent of the Contract Documents

1.2.1, 4.2.7, 4.2.12, 4.2.13

Interest

13.5

Interpretation

1.1.8, 1.2.3, **1.4**, 4.1.1, 5.1, 6.1.2, 15.1.1

Interpretations, Written

4.2.11, 4.2.12

Judgment on Final Award

15.4.2

Labor and Materials, Equipment

1.1.3, 1.1.6, **3.4**, 3.5, 3.8.2, 3.8.3, 3.12, 3.13, 3.15.1,

5.2.1, 6.2.1, 7.3.4, 9.3.2, 9.3.3, 9.5.1.3, 9.10.2, 10.2.1,

10.2.4, 14.2.1.1, 14.2.1.2

Labor Disputes

8.3.1

Laws and Regulations

1.5, 2.3.2, 3.2.3, 3.2.4, 3.6, 3.7, 3.12.10, 3.13, 9.6.4,

9.9.1, 10.2.2, 13.1, 13.3.1, 13.4.2, 13.5, 14, 15.2.8,

15.4

Liens

2.1.2, 9.3.1, 9.3.3, 9.6.8, 9.10.2, 9.10.4, 15.2.8

Limitations, Statutes of

12.2.5, 15.1.2, 15.4.1.1

Limitations of Liability

3.2.2, 3.5, 3.12.10, 3.12.10.1, 3.17, 3.18.1, 4.2.6,

4.2.7, 6.2.2, 9.4.2, 9.6.4, 9.6.7, 9.6.8, 10.2.5, 10.3.3,

11.3, 12.2.5, 13.3.1

Limitations of Time

2.1.2, 2.2, 2.5, 3.2.2, 3.10, 3.11, 3.12.5, 3.15.1, 4.2.7,

5.2, 5.3, 5.4.1, 6.2.4, 7.3, 7.4, 8.2, 9.2, 9.3.1, 9.3.3,

9.4.1, 9.5, 9.6, 9.7, 9.8, 9.9, 9.10, 12.2, 13.4, 14, 15,

15.1.2, 15.1.3, 15.1.5

Materials, Hazardous

10.2.4, 10.3

Materials, Labor, Equipment and

1.1.3, 1.1.6, 3.4.1, 3.5, 3.8.2, 3.8.3, 3.12, 3.13, 3.15.1,

5.2.1, 6.2.1, 7.3.4, 9.3.2, 9.3.3, 9.5.1.3, 9.10.2,

10.2.1.2, 10.2.4, 14.2.1.1, 14.2.1.2

Means, Methods, Techniques, Sequences and Procedures of Construction

3.3.1, 3.12.10, 4.2.2, 4.2.7, 9.4.2

Mechanic's Lien

2.1.2, 9.3.1, 9.3.3, 9.6.8, 9.10.2, 9.10.4, 15.2.8

Mediation

8.3.1, 15.1.3.2, 15.2.1, 15.2.5, 15.2.6, **15.3**, 15.4.1, 15.4.1.1

Minor Changes in the Work

1.1.1, 3.4.2, 3.12.8, 4.2.8, 7.1, **7.4**

MISCELLANEOUS PROVISIONS

13

Modifications, Definition of

1.1.1

Modifications to the Contract

1.1.1, 1.1.2, 2.5, 3.11, 4.1.2, 4.2.1, 5.2.3, 7, 8.3.1, 9.7, 10.3.2

Mutual Responsibility

6.2

Nonconforming Work, Acceptance of

9.6.6, 9.9.3, **12.3**

Nonconforming Work, Rejection and Correction of
2.4, 2.5, 3.5, 4.2.6, 6.2.4, 9.5.1, 9.8.2, 9.9.3, 9.10.4, 12.2

Notice

1.6, 1.6.1, 1.6.2, 2.1.2, 2.2.2., 2.2.3, 2.2.4, 2.5, 3.2.4, 3.3.1, 3.7.4, 3.7.5, 3.9.2, 3.12.9, 3.12.10, 5.2.1, 7.4, 8.2.2, 9.6.8, 9.7, 9.10.1, 10.2.8, 10.3.2, 11.5, 12.2.2.1, 13.4.1, 13.4.2, 14.1, 14.2.2, 14.4.2, 15.1.3, 15.1.5, 15.1.6, 15.4.1

Notice of Cancellation or Expiration of Insurance

11.1.4, 11.2.3

Notice of Claims

1.6.2, 2.1.2, 3.7.4, 9.6.8, 10.2.8, **15.1.3**, 15.1.5, 15.1.6, 15.2.8, 15.3.2, 15.4.1

Notice of Testing and Inspections

13.4.1, 13.4.2

Observations, Contractor's

3.2, 3.7.4

Occupancy

2.3.1, 9.6.6, 9.8

Orders, Written

1.1.1, 2.4, 3.9.2, 7, 8.2.2, 11.5, 12.1, 12.2.2.1, 13.4.2, 14.3.1

OWNER

2

Owner, Definition of

2.1.1

Owner, Evidence of Financial Arrangements

2.2, 13.2.2, 14.1.1.4

Owner, Information and Services Required of the

2.1.2, **2.2**, 2.3, 3.2.2, 3.12.10, 6.1.3, 6.1.4, 6.2.5, 9.3.2, 9.6.1, 9.6.4, 9.9.2, 9.10.3, 10.3.3, 11.2, 13.4.1, 13.4.2, 14.1.1.4, 14.1.4, 15.1.4

Owner's Authority

1.5, 2.1.1, 2.3.32.4, 2.5, 3.4.2, 3.8.1, 3.12.10, 3.14.2, 4.1.2, 4.2.4, 4.2.9, 5.2.1, 5.2.4, 5.4.1, 6.1, 6.3, 7.2.1,

7.3.1, 8.2.2, 8.3.1, 9.3.2, 9.5.1, 9.6.4, 9.9.1, 9.10.2, 10.3.2, 11.4, 11.5, 12.2.2, 12.3, 13.2.2, 14.3, 14.4, 15.2.7

Owner's Insurance

11.2

Owner's Relationship with Subcontractors

1.1.2, 5.2, 5.3, 5.4, 9.6.4, 9.10.2, 14.2.2

Owner's Right to Carry Out the Work

2.5, 14.2.2

Owner's Right to Clean Up

6.3

Owner's Right to Perform Construction and to Award Separate Contracts

6.1

Owner's Right to Stop the Work

2.4

Owner's Right to Suspend the Work

14.3

Owner's Right to Terminate the Contract

14.2, 14.4

Ownership and Use of Drawings, Specifications and Other Instruments of Service

1.1.1, 1.1.6, 1.1.7, **1.5**, 2.3.6, 3.2.2, 3.11, 3.17, 4.2.12, 5.3

Partial Occupancy or Use

9.6.6, **9.9**

Patching, Cutting and

3.14, 6.2.5

Patents

3.17

Payment, Applications for

4.2.5, 7.3.9, 9.2, **9.3**, 9.4, 9.5, 9.6.3, 9.7, 9.8.5, 9.10.1, 14.2.3, 14.2.4, 14.4.3

Payment, Certificates for

4.2.5, 4.2.9, 9.3.3, **9.4**, 9.5, 9.6.1, 9.6.6, 9.7, 9.10.1, 9.10.3, 14.1.1.3, 14.2.4

Payment, Failure of

9.5.1.3, **9.7**, 9.10.2, 13.5, 14.1.1.3, 14.2.1.2

Payment, Final

4.2.1, 4.2.9, **9.10**, 12.3, 14.2.4, 14.4.3

Payment Bond, Performance Bond and

7.3.4.4, 9.6.7, 9.10.3, **11.1.2**

Payments, Progress

9.3, **9.6**, 9.8.5, 9.10.3, 14.2.3, 15.1.4

PAYMENTS AND COMPLETION

9

Payments to Subcontractors

5.4.2, 9.5.1.3, 9.6.2, 9.6.3, 9.6.4, 9.6.7, 14.2.1.2

PCB

10.3.1

Performance Bond and Payment Bond

7.3.4.4, 9.6.7, 9.10.3, **11.1.2**

Permits, Fees, Notices and Compliance with Laws

2.3.1, **3.7**, 3.13, 7.3.4.4, 10.2.2

PERSONS AND PROPERTY, PROTECTION OF
10

Init.

/

AIA Document A201® – 2017. Copyright © 1911, 1915, 1918, 1925, 1937, 1951, 1958, 1961, 1963, 1966, 1970, 1976, 1987, 1997, 2007 and 2017 by The American Institute of Architects. All rights reserved. The "American Institute of Architects," "AIA," the AIA Logo, "A201," and "AIA Contract Documents" are registered trademarks and may not be used without permission. This document was produced by AIA software at 15:51:23 ET on 04/27/2021 under Order No.5027455636 which expires on 07/12/2021, is not for resale, is licensed for one-time use only, and may only be used in accordance with the AIA Contract Documents® Terms of Service. To report copyright violations, e-mail copyright@aia.org.
User Notes:

(1783516235)

Polychlorinated Biphenyl
10.3.1
Product Data, Definition of
3.12.2
Product Data and Samples, Shop Drawings
3.11, **3.12**, 4.2.7
Progress and Completion
4.2.2, **8.2**, 9.8, 9.9.1, 14.1.4, 15.1.4
Progress Payments
9.3, **9.6**, 9.8.5, 9.10.3, 14.2.3, 15.1.4
Project, Definition of
1.1.4
Project Representatives
4.2.10
Property Insurance
10.2.5, **11.2**
Proposal Requirements
1.1.1
PROTECTION OF PERSONS AND PROPERTY
10
Regulations and Laws
1.5, 2.3.2, 3.2.3, 3.6, 3.7, 3.12.10, 3.13, 9.6.4, 9.9.1,
10.2.2, 13.1, 13.3, 13.4.1, 13.4.2, 13.5, 14, 15.2.8, 15.4
Rejection of Work
4.2.6, 12.2.1
Releases and Waivers of Liens
9.3.1, 9.10.2
Representations
3.2.1, 3.5, 3.12.6, 8.2.1, 9.3.3, 9.4.2, 9.5.1, 9.10.1
Representatives
2.1.1, 3.1.1, 3.9, 4.1.1, 4.2.10, 13.2.1
Responsibility for Those Performing the Work
3.3.2, 3.18, 4.2.2, 4.2.3, 5.3, 6.1.3, 6.2, 6.3, 9.5.1, 10
Retainage
9.3.1, 9.6.2, 9.8.5, 9.9.1, 9.10.2, 9.10.3
Review of Contract Documents and Field
Conditions by Contractor
3.2, 3.12.7, 6.1.3
Review of Contractor's Submittals by Owner and
Architect
3.10.1, 3.10.2, 3.11, 3.12, 4.2, 5.2, 6.1.3, 9.2, 9.8.2
Review of Shop Drawings, Product Data and Samples
by Contractor
3.12
Rights and Remedies
1.1.2, 2.4, 2.5, 3.5, 3.7.4, 3.15.2, 4.2.6, 5.3, 5.4, 6.1,
6.3, 7.3.1, 8.3, 9.5.1, 9.7, 10.2.5, 10.3, 12.2.1, 12.2.2,
12.2.4, **13.3**, 14, 15.4
Royalties, Patents and Copyrights
3.17
Rules and Notices for Arbitration
15.4.1
Safety of Persons and Property
10.2, 10.4
Safety Precautions and Programs
3.3.1, 4.2.2, 4.2.7, 5.3, **10.1**, 10.2, 10.4

Samples, Definition of
3.12.3
Samples, Shop Drawings, Product Data and
3.11, **3.12**, 4.2.7
Samples at the Site, Documents and
3.11
Schedule of Values
9.2, 9.3.1
Schedules, Construction
3.10, 3.12.1, 3.12.2, 6.1.3, 15.1.6.2
Separate Contracts and Contractors
1.1.4, 3.12.5, 3.14.2, 4.2.4, 4.2.7, 6, 8.3.1, 12.1.2
Separate Contractors, Definition of
6.1.1
Shop Drawings, Definition of
3.12.1
Shop Drawings, Product Data and Samples
3.11, **3.12**, 4.2.7
Site, Use of
3.13, 6.1.1, 6.2.1
Site Inspections
3.2.2, 3.3.3, 3.7.1, 3.7.4, 4.2, 9.9.2, 9.4.2, 9.10.1, 13.4
Site Visits, Architect's
3.7.4, 4.2.2, 4.2.9, 9.4.2, 9.5.1, 9.9.2, 9.10.1, 13.4
Special Inspections and Testing
4.2.6, 12.2.1, 13.4
Specifications, Definition of
1.1.6
Specifications
1.1.1, **1.1.6**, 1.2.2, 1.5, 3.12.10, 3.17, 4.2.14
Statute of Limitations
15.1.2, 15.4.1.1
Stopping the Work
2.2.2, 2.4, 9.7, 10.3, 14.1
Stored Materials
6.2.1, 9.3.2, 10.2.1.2, 10.2.4
Subcontractor, Definition of
5.1.1
SUBCONTRACTORS
5
Subcontractors, Work by
1.2.2, 3.3.2, 3.12.1, 3.18, 4.2.3, 5.2.3, 5.3, 5.4, 9.3.1.2,
9.6.7
Subcontractual Relations
5.3, 5.4, 9.3.1.2, 9.6, 9.10, 10.2.1, 14.1, 14.2.1
Submittals
3.10, 3.11, 3.12, 4.2.7, 5.2.1, 5.2.3, 7.3.4, 9.2, 9.3, 9.8,
9.9.1, 9.10.2, 9.10.3
Submittal Schedule
3.10.2, 3.12.5, 4.2.7
Subrogation, Waivers of
6.1.1, **11.3**
Substances, Hazardous
10.3
Substantial Completion
4.2.9, 8.1.1, 8.1.3, 8.2.3, 9.4.2, **9.8**, 9.9.1, 9.10.3, 12.2,
15.1.2

Substantial Completion, Definition of

9.8.1

Substitution of Subcontractors

5.2.3, 5.2.4

Substitution of Architect

2.3.3

Substitutions of Materials

3.4.2, 3.5, 7.3.8

Sub-subcontractor, Definition of

5.1.2

Subsurface Conditions

3.7.4

Successors and Assigns

13.2

Superintendent

3.9, 10.2.6

Supervision and Construction Procedures

1.2.2, **3.3**, 3.4, 3.12.10, 4.2.2, 4.2.7, 6.1.3, 6.2.4, 7.1.3,

7.3.4, 8.2, 8.3.1, 9.4.2, 10, 12, 14, 15.1.4

Suppliers

1.5, 3.12.1, 4.2.4, 4.2.6, 5.2.1, 9.3, 9.4.2, 9.5.4, 9.6,

9.10.5, 14.2.1

Surety

5.4.1.2, 9.6.8, 9.8.5, 9.10.2, 9.10.3, 11.1.2, 14.2.2,

15.2.7

Surety, Consent of

9.8.5, 9.10.2, 9.10.3

Surveys

1.1.7, 2.3.4

Suspension by the Owner for Convenience

14.3

Suspension of the Work

3.7.5, 5.4.2, 14.3

Suspension or Termination of the Contract

5.4.1.1, 14

Taxes

3.6, 3.8.2.1, 7.3.4.4

Termination by the Contractor

14.1, 15.1.7

Termination by the Owner for Cause

5.4.1.1, **14.2**, 15.1.7

Termination by the Owner for Convenience

14.4

Termination of the Architect

2.3.3

Termination of the Contractor Employment

14.2.2

TERMINATION OR SUSPENSION OF THE CONTRACT

14

Tests and Inspections

3.1.3, 3.3.3, 3.7.1, 4.2.2, 4.2.6, 4.2.9, 9.4.2, 9.8.3,

9.9.2, 9.10.1, 10.3.2, 12.2.1, **13.4**

TIME

8

Time, Delays and Extensions of

3.2.4, 3.7.4, 5.2.3, 7.2.1, 7.3.1, 7.4, **8.3**, 9.5.1, 9.7,

10.3.2, 10.4, 14.3.2, 15.1.6, 15.2.5

Time Limits

2.1.2, 2.2, 2.5, 3.2.2, 3.10, 3.11, 3.12.5, 3.15.1, 4.2,

5.2, 5.3, 5.4, 6.2.4, 7.3, 7.4, 8.2, 9.2, 9.3.1, 9.3.3, 9.4.1,

9.5, 9.6, 9.7, 9.8, 9.9, 9.10, 12.2, 13.4, 14, 15.1.2,

15.1.3, 15.4

Time Limits on Claims

3.7.4, 10.2.8, 15.1.2, 15.1.3

Title to Work

9.3.2, 9.3.3

UNCOVERING AND CORRECTION OF WORK

12

Uncovering of Work

12.1

Unforeseen Conditions, Concealed or Unknown

3.7.4, 8.3.1, 10.3

Unit Prices

7.3.3.2, 9.1.2

Use of Documents

1.1.1, 1.5, 2.3.6, 3.12.6, 5.3

Use of Site

3.13, 6.1.1, 6.2.1

Values, Schedule of

9.2, 9.3.1

Waiver of Claims by the Architect

13.3.2

Waiver of Claims by the Contractor

9.10.5, 13.3.2, **15.1.7**

Waiver of Claims by the Owner

9.9.3, 9.10.3, 9.10.4, 12.2.2.1, 13.3.2, 14.2.4, **15.1.7**

Waiver of Consequential Damages

14.2.4, 15.1.7

Waiver of Liens

9.3, 9.10.2, 9.10.4

Waivers of Subrogation

6.1.1, **11.3**

Warranty

3.5, 4.2.9, 9.3.3, 9.8.4, 9.9.1, 9.10.2, 9.10.4, 12.2.2,

15.1.2

Weather Delays

8.3, 15.1.6.2

Work, Definition of

1.1.3

Written Consent

1.5.2, 3.4.2, 3.7.4, 3.12.8, 3.14.2, 4.1.2, 9.3.2, 9.10.3,

13.2, 13.3.2, 15.4.4.2

Written Interpretations

4.2.11, 4.2.12

Written Orders

1.1.1, 2.4, 3.9, 7, 8.2.2, 12.1, 12.2, 13.4.2, 14.3.1

ARTICLE 1 GENERAL PROVISIONS

§ 1.1 Basic Definitions

§ 1.1.1 The Contract Documents

The Contract Documents are enumerated in the Agreement between the Owner and Contractor (hereinafter the Agreement) and consist of the Agreement, Conditions of the Contract (General, Supplementary and other Conditions), Drawings, Specifications, Addenda issued prior to execution of the Contract, other documents listed in the Agreement, and Modifications issued after execution of the Contract. A Modification is (1) a written amendment to the Contract signed by both parties, (2) a Change Order, (3) a Construction Change Directive, or (4) a written order for a minor change in the Work issued by the Architect. Unless specifically enumerated in the Agreement, the Contract Documents do not include the advertisement or invitation to bid, Instructions to Bidders, sample forms, other information furnished by the Owner in anticipation of receiving bids or proposals, the Contractor's bid or proposal, or portions of Addenda relating to bidding or proposal requirements.

§ 1.1.2 The Contract

The Contract Documents form the Contract for Construction. The Contract represents the entire and integrated agreement between the parties hereto and supersedes prior negotiations, representations, or agreements, either written or oral. The Contract may be amended or modified only by a Modification. The Contract Documents shall not be construed to create a contractual relationship of any kind (1) between the Contractor and the Architect or the Architect's consultants, (2) between the Owner and a Subcontractor or a Sub-subcontractor, (3) between the Owner and the Architect or the Architect's consultants, or (4) between any persons or entities other than the Owner and the Contractor. The Architect shall, however, be entitled to performance and enforcement of obligations under the Contract intended to facilitate performance of the Architect's duties.

§ 1.1.3 The Work

The term "Work" means the construction and services required by the Contract Documents, whether completed or partially completed, and includes all other labor, materials, equipment, and services provided or to be provided by the Contractor to fulfill the Contractor's obligations. The Work may constitute the whole or a part of the Project.

§ 1.1.4 The Project

The Project is the total construction of which the Work performed under the Contract Documents may be the whole or a part and which may include construction by the Owner and by Separate Contractors.

§ 1.1.5 The Drawings

The Drawings are the graphic and pictorial portions of the Contract Documents showing the design, location and dimensions of the Work, generally including plans, elevations, sections, details, schedules, and diagrams.

§ 1.1.6 The Specifications

The Specifications are that portion of the Contract Documents consisting of the written requirements for materials, equipment, systems, standards and workmanship for the Work, and performance of related services.

§ 1.1.7 Instruments of Service

Instruments of Service are representations, in any medium of expression now known or later developed, of the tangible and intangible creative work performed by the Architect and the Architect's consultants under their respective professional services agreements. Instruments of Service may include, without limitation, studies, surveys, models, sketches, drawings, specifications, and other similar materials.

§ 1.1.8 Initial Decision Maker

The Initial Decision Maker is the person identified in the Agreement to render initial decisions on Claims in accordance with Section 15.2. The Initial Decision Maker shall not show partiality to the Owner or Contractor and shall not be liable for results of interpretations or decisions rendered in good faith.

§ 1.1.9 Written Notice

Written notice shall mean a written instrument and shall be deemed to have been duly served if delivered in person to the individual, to a member of the firm or entity, or to an officer of the corporation for which it was intended; or if delivered at, or sent by registered or certified mail or by courier service providing proof of delivery to, the last business address known to the party giving notice.

Written Notice to the Owner shall be directed to the Project Manager identified in Division 1 of the Specifications.

Written Notice to the Contractor shall be directed to the Contractor's Project Manager.

Written Notice to the Architect shall be directed to the individual identified at the pre-construction meeting.

§ 1.2 Correlation and Intent of the Contract Documents

§ 1.2.1 The intent of the Contract Documents is to include all items necessary for the proper execution and completion of the Work by the Contractor. The Contract Documents are complementary, and what is required by one shall be as binding as if required by all; performance by the Contractor shall be required only to the extent consistent with the Contract Documents and reasonably inferable from them as being necessary to produce the indicated results. In the case of an inconsistency between Drawings and Specifications and within either Contract Document not clarified by Addendum, the better quality or greater quantity of Work shall be provided in accordance with the Architect's/Engineer's interpretation.

§ 1.2.1.1 The invalidity of any provision of the Contract Documents shall not invalidate the Contract or its remaining provisions. If it is determined that any provision of the Contract Documents violates any law, or is otherwise invalid or unenforceable, then that provision shall be revised to the extent necessary to make that provision legal and enforceable. In such case the Contract Documents shall be construed, to the fullest extent permitted by law, to give effect to the parties' intentions and purposes in executing the Contract.

§ 1.2.2 Organization of the Specifications into divisions, sections and articles, and arrangement of Drawings shall not control the Contractor in dividing the Work among Subcontractors or in establishing the extent of Work to be performed by any trade.

§ 1.2.3 Unless otherwise stated in the Contract Documents, words that have well-known technical or construction industry meanings are used in the Contract Documents in accordance with such recognized meanings.

§ 1.3 Capitalization

Terms capitalized in these General Conditions include those that are (1) specifically defined, (2) the titles of numbered articles, or (3) the titles of other documents published by the American Institute of Architects.

§ 1.4 Interpretation

In the interest of brevity the Contract Documents frequently omit modifying words such as "all" and "any" and articles such as "the" and "an," but the fact that a modifier or an article is absent from one statement and appears in another is not intended to affect the interpretation of either statement.

§ 1.5 Ownership and Use of Drawings, Specifications, and Other Instruments of Service

§ 1.5.1 The Architect and the Architect's consultants shall be deemed the authors and owners of their respective Instruments of Service, including the Drawings and Specifications, and except as may otherwise be provided in the Agreement between Owner and Architect will retain all common law, statutory, and other reserved rights, including copyrights. The Contractor, Subcontractors, Sub-subcontractors, and suppliers shall not own or claim a copyright in the Instruments of Service. Submittal or distribution to meet official regulatory requirements or for other purposes in connection with the Project is not to be construed as publication in derogation of the Owner's, Architect's or Architect's consultants' reserved rights.

§ 1.5.2 The Contractor, Subcontractors, Sub-subcontractors, and suppliers are authorized to use and reproduce the Instruments of Service provided to them, subject to any protocols established pursuant to Sections 1.7 and 1.8, solely and exclusively for execution of the Work. All copies made under this authorization shall bear the copyright notice, if any, shown on the Instruments of Service. The Contractor, Subcontractors, Sub-subcontractors, and suppliers may not use the Instruments of Service on other projects or for additions to the Project outside the scope of the Work without the specific written consent of the Owner, Architect, and the Architect's consultants.

§ 1.6 Notice

§ 1.6.1 Except as otherwise provided in Section 1.6.2, where the Contract Documents require one party to notify or give notice to the other party, such notice shall be provided in writing to the designated representative of the party to whom the notice is addressed and shall be deemed to have been duly served if delivered in person, by mail, by courier, or by electronic transmission if a method for electronic transmission is set forth in the Agreement.

Init.

§ 1.6.2 Notice of Claims as provided in Section 15.1.3 shall be provided in writing and shall be deemed to have been duly served only if delivered to the designated representative of the party to whom the notice is addressed by certified or registered mail, or by courier providing proof of delivery.

§ 1.7 Digital Data Use and Transmission

If the parties intend to transmit Instruments of Service or any other information or documentation in digital form, they shall endeavor to establish necessary protocols governing such transmissions, unless otherwise already provided in the Agreement or the Contract Documents.

§ 1.8 Building Information Models Use and Reliance

Any use of, or reliance on, all or a portion of a building information model shall be at the using or relying party's sole risk and without liability to the other party and its contractors or consultants, the authors of, or contributors to, the building information model, and each of their agents and employees.

ARTICLE 2 OWNER

§ 2.1 General

§ 2.1.1 The Owner is the person or entity identified as such in the Agreement and is referred to throughout the Contract Documents as if singular in number. The Owner shall designate in writing a representative who shall have express authority to bind the Owner with respect to all matters requiring the Owner's approval or authorization. Except as otherwise provided in Section 4.2.1, the Architect does not have such authority. The term "Owner" means the Owner or the Owner's authorized representative.

§ 2.1.2 Deleted

§ 2.2 Deleted

(Paragraphs deleted)

§ 2.3 Information and Services Required of the Owner

§ 2.3.1 Except for permits and fees that are the responsibility of the Contractor under the Contract Documents, including those required under Section 3.7.1, the Owner shall secure and pay for necessary approvals, easements, assessments and charges required for construction, use or occupancy of permanent structures or for permanent changes in existing facilities.

§ 2.3.2 The Owner shall retain an architect lawfully licensed to practice architecture, or an entity lawfully practicing architecture, in the jurisdiction where the Project is located. That person or entity is identified as the Architect in the Agreement and is referred to throughout the Contract Documents as if singular in number.

§ 2.3.3 Deleted

§ 2.3.4 The Owner shall furnish surveys describing physical characteristics, legal limitations and utility locations for the site of the Project, and a legal description of the site. The Contractor shall be entitled to rely on the accuracy of information furnished by the Owner but shall exercise proper precautions relating to the safe performance of the Work.

§ 2.3.5 The Owner shall furnish information or services required of the Owner by the Contract Documents with reasonable promptness. The Owner shall also furnish any other information or services under the Owner's control and relevant to the Contractor's performance of the Work with reasonable promptness after receiving the Contractor's written request for such information or services.

§ 2.3.6 Unless otherwise provided in the Contract Documents, the Owner shall furnish to the Contractor one copy of the Contract Documents for purposes of making reproductions pursuant to Section 1.5.2.

§ 2.4 Owner's Right to Stop the Work

If the Contractor fails to correct Work that is not in accordance with the requirements of the Contract Documents as required by Section 12.2 or repeatedly fails to carry out Work in accordance with the Contract Documents, the Owner may issue a written order to the Contractor to stop the Work, or any portion thereof, until the cause for such order has

Init.

been eliminated; however, the right of the Owner to stop the Work shall not give rise to a duty on the part of the Owner to exercise this right for the benefit of the Contractor or any other person or entity, except to the extent required by Section 6.1.3.

§ 2.5 Owner's Right to Carry Out the Work

If the Contractor defaults or neglects to carry out the Work in accordance with the Contract Documents and fails within a five-day period after receipt of notice from the Owner to commence and continue correction of such default or neglect with diligence and promptness, the Owner may, without prejudice to other remedies the Owner may have, correct such deficiencies. In such case an appropriate Change Order shall be issued deducting from payments then or thereafter due the Contractor the reasonable cost of correcting such deficiencies, including Owner's expenses and compensation for the Architect's additional services made necessary by such default, neglect or failure. If payments then or thereafter due the Contractor are not sufficient to cover such amounts, the Contractor shall pay the difference to the Owner.

ARTICLE 3 CONTRACTOR

§ 3.1 General

§ 3.1.1 The Contractor is the person or entity identified as such in the Agreement and is referred to throughout the Contract Documents as if singular in number. The Contractor shall be lawfully licensed, if required in the jurisdiction where the Project is located. The Contractor shall designate in writing a representative who shall have express authority to bind the Contractor with respect to all matters under this Contract. The term "Contractor" means the Contractor or the Contractor's authorized representative.

§ 3.1.2 The Contractor shall perform the Work in accordance with the Contract Documents.

§ 3.1.3 The Contractor shall not be relieved of its obligations to perform the Work in accordance with the Contract Documents either by activities or duties of the Architect in the Architect's administration of the Contract, or by tests, inspections or approvals required or performed by persons or entities other than the Contractor.

§ 3.2 Review of Contract Documents and Field Conditions by Contractor

§ 3.2.1 Execution of the Contract by the Contractor is a representation that the Contractor has visited the site, become generally familiar with local conditions under which the Work is to be performed, and correlated personal observations with requirements of the Contract Documents.

§ 3.2.2 Because the Contract Documents are complementary, the Contractor shall, before starting each portion of the Work, carefully study and compare the various Contract Documents relative to that portion of the Work, as well as the information furnished by the Owner pursuant to Section 2.3.4, shall take field measurements of any existing conditions related to that portion of the Work, and shall observe any conditions at the site affecting it. These obligations are for the purpose of facilitating coordination and construction by the Contractor and are not for the purpose of discovering errors, omissions, or inconsistencies in the Contract Documents; however, the Contractor shall promptly report to the Architect any errors, inconsistencies or omissions discovered by or made known to the Contractor as a request for information in such form as the Architect may require. It is recognized that the Contractor's review is made in the Contractor's capacity as a contractor and not as a licensed design professional, unless otherwise specifically provided in the Contract Documents.

§ 3.2.3 The Contractor is not required to ascertain that the Contract Documents are in accordance with applicable laws, statutes, ordinances, codes, rules and regulations, or lawful orders of public authorities, but the Contractor shall promptly report to the Architect any nonconformity discovered by or made known to the Contractor as a request for information in such form as the Architect may require.

§ 3.2.4 If the Contractor believes that additional cost or time is involved because of clarifications or instructions the Architect issues in response to the Contractor's notices or requests for information pursuant to Sections 3.2.2 or 3.2.3, the Contractor shall submit Claims as provided in Article 15. If the Contractor fails to perform the obligations of Sections 3.2.2 or 3.2.3, the Contractor shall pay such costs and damages to the Owner, as would have been avoided if the Contractor had performed such obligations. If the Contractor performs those obligations, the Contractor shall not be liable to the Owner or Architect for damages resulting from errors, inconsistencies or omissions in the Contract Documents, for differences between field measurements or conditions and the Contract Documents, or for

nonconformities of the Contract Documents to applicable laws, statutes, ordinances, codes, rules and regulations, and lawful orders of public authorities.

§ 3.3 Supervision and Construction Procedures

§ 3.3.1 The Contractor shall supervise and direct the Work, using the Contractor's best skill and attention. The Contractor shall be solely responsible for, and have control over, construction means, methods, techniques, sequences, and procedures, and for coordinating all portions of the Work under the Contract. If the Contract Documents give specific instructions concerning construction means, methods, techniques, sequences, or procedures, the Contractor shall evaluate the jobsite safety thereof and shall be solely responsible for the jobsite safety of such means, methods, techniques, sequences, or procedures. If the Contractor determines that such means, methods, techniques, sequences or procedures may not be safe, the Contractor shall give timely notice to the Owner and Architect, and shall propose alternative means, methods, techniques, sequences, or procedures. The Architect shall evaluate the proposed alternative solely for conformance with the design intent for the completed construction. Unless the Architect objects to the Contractor's proposed alternative, the Contractor shall perform the Work using its alternative means, methods, techniques, sequences, or procedures.

§ 3.3.2 The Contractor shall be responsible to the Owner for acts and omissions of the Contractor's employees, Subcontractors and their agents and employees, and other persons or entities performing portions of the Work for, or on behalf of, the Contractor or any of its Subcontractors.

§ 3.3.3 The Contractor shall be responsible for inspection of portions of Work already performed to determine that such portions are in proper condition to receive subsequent Work.

§ 3.4 Labor and Materials

§ 3.4.1 Unless otherwise provided in the Contract Documents, the Contractor shall provide and pay for labor, materials, equipment, tools, construction equipment and machinery, water, heat, utilities, transportation, and other facilities and services necessary for proper execution and completion of the Work, whether temporary or permanent and whether or not incorporated or to be incorporated in the Work.

§ 3.4.2 Except in the case of minor changes in the Work approved by the Architect in accordance with Section 3.12.8 or ordered by the Architect in accordance with Section 7.4, the Contractor may make substitutions only with the consent of the Owner, after evaluation by the Architect and in accordance with a Change Order or Construction Change Directive.

§ 3.4.3 The Contractor shall enforce strict discipline and good order among the Contractor's employees and other persons carrying out the Work. The Contractor shall not permit employment of unfit persons or persons not properly skilled in tasks assigned to them. The Owner reserves the right to require the Contractor to remove from the Project any employee of the Contractor (including the General Superintendent), any Subcontractor or employee of any Subcontractor if the Owner deems such person to be unfit or otherwise unsatisfactory.

§ 3.5 Warranty

§ 3.5.1 The Contractor warrants to the Owner and Architect that materials and equipment furnished under the Contract will be of good quality and new unless the Contract Documents require or permit otherwise. The Contractor further warrants that the Work will conform to the requirements of the Contract Documents and will be free from defects, except for those inherent in the quality of the Work the Contract Documents require or permit. Work, materials, or equipment not conforming to these requirements may be considered defective. The Contractor's warranty excludes remedy for damage or defect caused by abuse, alterations to the Work not executed by the Contractor, improper or insufficient maintenance, improper operation, or normal wear and tear and normal usage. If required by the Architect, the Contractor shall furnish satisfactory evidence as to the kind and quality of materials and equipment.

§ 3.5.2 All material, equipment, or other special warranties required by the Contract Documents shall be issued in the name of the Owner, or shall be transferable to the Owner, and shall commence in accordance with Section 9.8.4.

§ 3.6 Taxes

The Contractor shall pay sales, consumer, use and similar taxes for the Work provided by the Contractor that are legally enacted when bids are received or negotiations concluded, whether or not yet effective or merely scheduled to go into effect.

Init.

§ 3.6.1 The labor and materials furnished under this Contract will be used, when the Project is completed, by the Owner for its tax exempt purposes. Accordingly, the Indiana Gross Retail and Use Tax (sales and use tax) will not apply to the purchase of materials under this Contract by the Owner from the Contractor. The Owner will issue an appropriate exemption certificate to the Contractor to that effect.

§ 3.7 Permits, Fees, Notices and Compliance with Laws

§ 3.7.1 Unless otherwise provided in the Contract Documents, the Contractor shall secure and pay for any permits, fees, licenses, and inspections by government agencies necessary for the means and methods employed by Contractor to complete the Work that are customarily secured after execution of the Contract.

§ 3.7.2 The Contractor shall comply with and give notices required by applicable laws, statutes, ordinances, codes, rules and regulations, and lawful orders of public authorities applicable to performance of the Work regardless of whether they are specifically identified in the Contract Documents. Contractor shall furnish Architect and Owner with copies of all notices given.

§ 3.7.3 If the Contractor performs Work knowing or suspecting it to be contrary to applicable laws, statutes, ordinances, codes, rules and regulations, or lawful orders of public authorities, the Contractor shall assume full responsibility for such Work and shall bear all costs attributable to correction.

§ 3.7.4 Concealed or Unknown Conditions

If the Contractor encounters conditions at the site that are (1) subsurface or otherwise concealed physical conditions that differ materially from those indicated in the Contract Documents or (2) unknown physical conditions of an unusual nature that differ materially from those ordinarily found to exist and generally recognized as inherent in construction activities of the character provided for in the Contract Documents, the Contractor shall promptly provide notice to the Owner and the Architect before conditions are disturbed and in no event later than 14 days after first observance of the conditions. The Architect will promptly investigate such conditions and, if the Architect determines that they differ materially and cause an increase or decrease in the Contractor's cost of, or time required for, performance of any part of the Work, will recommend that an equitable adjustment be made in the Contract Sum or Contract Time, or both. If the Architect determines that the conditions at the site are not materially different from those indicated in the Contract Documents and that no change in the terms of the Contract is justified, the Architect shall promptly notify the Owner and Contractor, stating the reasons. If either party disputes the Architect's determination or recommendation, that party may submit a Claim as provided in Article 15.

§ 3.7.5 If, in the course of the Work, the Contractor encounters human remains or recognizes the existence of burial markers, archaeological sites or wetlands not indicated in the Contract Documents, the Contractor shall immediately suspend any operations that would affect them and shall notify the Owner and Architect. Upon receipt of such notice, the Owner shall promptly take any action necessary to obtain governmental authorization required to resume the operations. The Contractor shall continue to suspend such operations until otherwise instructed by the Owner but shall continue with all other operations that do not affect those remains or features. Requests for adjustments in the Contract Sum and Contract Time arising from the existence of such remains or features may be made as provided in Article 15.

§ 3.8 Allowances

§ 3.8.1 The Contractor shall include in the Contract Sum all allowances stated in the Contract Documents. Items covered by allowances shall be supplied for such amounts and by such persons or entities as the Owner may direct, but the Contractor shall not be required to employ persons or entities to whom the Contractor has reasonable objection.

§ 3.8.2 Unless otherwise provided in the Contract Documents,

- .1 allowances shall cover the cost to the Contractor of materials and equipment delivered at the site and all required taxes, less applicable trade discounts;
- .2 Contractor's costs for unloading and handling at the site, labor, installation costs, overhead, profit, and other expenses contemplated for stated allowance amounts shall be included in the Contract Sum but not in the allowances; and
- .3 whenever costs are more than or less than allowances, the Contract Sum shall be adjusted accordingly by Change Order. The amount of the Change Order shall reflect (1) the difference between actual costs and the allowances under Section 3.8.2.1 and (2) changes in Contractor's costs under Section 3.8.2.2.

§ 3.8.3 Materials and equipment under an allowance shall be selected by the Owner with reasonable promptness.

§ 3.9 Superintendent

§ 3.9.1 The Contractor shall employ a competent superintendent and necessary assistants who shall be in attendance at the Project site during performance of the Work. The superintendent shall represent the Contractor, and communications given to the superintendent shall be as binding as if given to the Contractor.

§ 3.9.2 Within seven days after Contractor's bid is received and opened the Contractor shall furnish in writing to the Owner through the Architect the name and qualifications of a proposed superintendent. The Architect may reply within 14 days to the Contractor in writing stating (1) whether the Owner or the Architect has reasonable objection to the proposed superintendent or (2) that the Architect requires additional time to review. Failure of the Architect to reply within the 14 day period shall constitute notice of no reasonable objection.

§ 3.9.3 The Contractor shall not employ a proposed superintendent to whom the Owner or Architect has made reasonable and timely objection. The Contractor shall not change the superintendent without the Owner's consent, which shall not unreasonably be withheld or delayed. Once approved, the Contractor's superintendent may not be changed without the written permission of the Owner, which shall not be unreasonably withheld.

§ 3.9.4 Contractor's superintendent shall devote his full attention to the Project and shall not superintend any other projects for the Contractor without the written consent of the Owner, which shall not be unreasonably withheld.

§ 3.10 Contractor's Construction and Submittal Schedules

§ 3.10.1 The Contractor, immediately after being awarded the Contract, shall prepare and submit for the Owner's and Architect's information a Contractor's construction schedule for the Work in accordance with the requirements of Division One of the Specifications. The schedule shall not exceed time limits current under the Contract Documents, shall be revised at monthly intervals or more often as required by the Owner, shall be related to the entire Project to the extent required by the Contract Documents, and shall provide for expeditious and practicable execution of the Work.

§ 3.10.2 The Contractor shall prepare a submittal schedule, immediately after being awarded the Contract and thereafter as necessary to maintain a current submittal schedule, and shall submit the schedule(s) for the Architect's approval. The Architect's approval shall not unreasonably be delayed or withheld. The submittal schedule shall (1) be coordinated with the Contractor's construction schedule, and (2) allow the Architect reasonable time to review submittals. If the Contractor fails to submit a submittal schedule, or fails to provide submittals in accordance with the approved submittal schedule, the Contractor shall not be entitled to any increase in Contract Sum or extension of Contract Time based on the time required for review of submittals.

§ 3.10.3 The Contractor shall perform the Work in general accordance with the most recent schedules submitted to the Owner and Architect. Contractor's failure to submit satisfactory information required by this § 3.10 shall be grounds for delaying or withholding payment to Contractor.

§ 3.10.4 The Contractor shall not interrupt, disrupt or in any way interfere with utility service to the Owner's existing buildings and structures unless required in order to properly perform the Work. Any necessary interruption, disruption or interference shall be specifically identified in Contractor's construction schedule for the Work and shall be closely coordinated with the Owner so as to minimize the impact to Owner's operations.

§ 3.11 Documents and Samples at the Site

The Contractor shall make available, at the Project site, the Contract Documents, including Change Orders, Construction Change Directives, and other Modifications, in good order and marked currently to indicate field changes and selections made during construction, and the approved Shop Drawings, Product Data, Samples, and similar required submittals. These shall be in electronic form or paper copy, available to the Architect and Owner, and delivered to the Architect for submittal to the Owner upon completion of the Work as a record of the Work as constructed.

§ 3.12 Shop Drawings, Product Data and Samples

§ 3.12.1 Shop Drawings are drawings, diagrams, schedules, and other data specially prepared for the Work by the Contractor or a Subcontractor, Sub-subcontractor, manufacturer, supplier, or distributor to illustrate some portion of the Work.

§ 3.12.2 Product Data are illustrations, standard schedules, performance charts, instructions, brochures, diagrams, and other information furnished by the Contractor to illustrate materials or equipment for some portion of the Work.

§ 3.12.3 Samples are physical examples that illustrate materials, equipment, or workmanship, and establish standards by which the Work will be judged.

§ 3.12.4 Shop Drawings, Product Data, Samples, and similar submittals are not Contract Documents. Their purpose is to demonstrate how the Contractor proposes to conform to the information given and the design concept expressed in the Contract Documents for those portions of the Work for which the Contract Documents require submittals. Review by the Architect is subject to the limitations of Section 4.2.7. Informational submittals upon which the Architect is not expected to take responsive action may be so identified in the Contract Documents. Submittals that are not required by the Contract Documents may be returned by the Architect without action.

§ 3.12.5 The Contractor shall review for compliance with the Contract Documents, approve, and submit to the Architect, Shop Drawings, Product Data, Samples, and similar submittals required by the Contract Documents, in accordance with the submittal schedule approved by the Architect or, in the absence of an approved submittal schedule, with reasonable promptness and in such sequence as to cause no delay in the Work or in the activities of the Owner or of Separate Contractors.

§ 3.12.5.1 Each Shop Drawing, Product Data, Sample or similar submittal shall bear the following wording typed or stamped thereon: "APPROVED TO BE IN ACCORDANCE WITH THE CONTRACT DOCUMENTS EXCEPT AS NOTED."

SIGNED: _____ DATED: _____

Any Shop Drawing, Product Data, Sample, or similar submittal submitted without the above wording shall be returned without review for resubmittal.

§ 3.12.6 By submitting Shop Drawings, Product Data, Samples, and similar submittals, the Contractor represents to the Owner and Architect that the Contractor has (1) reviewed and approved them, (2) determined and verified materials, field measurements and field construction criteria related thereto, or will do so, and (3) checked and coordinated the information contained within such submittals with the requirements of the Work and of the Contract Documents.

§ 3.12.7 The Contractor shall perform no portion of the Work for which the Contract Documents require submittal and review of Shop Drawings, Product Data, Samples, or similar submittals, until the respective submittal has been approved by the Architect. Any work performed by the Contractor in violation of this section shall be at Contractor's sole risk.

§ 3.12.8 The Work shall be in accordance with approved submittals except that the Contractor shall not be relieved of responsibility for deviations from the requirements of the Contract Documents by the Architect's approval of Shop Drawings, Product Data, Samples, or similar submittals, unless the Contractor has specifically notified the Architect of such deviation at the time of submittal and (1) the Architect has given written approval to the specific deviation as a minor change in the Work, or (2) a Change Order or Construction Change Directive has been issued authorizing the deviation. The Contractor shall not be relieved of responsibility for errors or omissions in Shop Drawings, Product Data, Samples, or similar submittals, by the Architect's approval thereof.

§ 3.12.9 The Contractor shall direct specific attention, in writing or on resubmitted Shop Drawings, Product Data, Samples, or similar submittals, to revisions other than those requested by the Architect on previous submittals. In the absence of such notice, the Architect's approval of a resubmission shall not apply to such revisions.

§ 3.12.10 The Contractor shall not be required to provide professional services that constitute the practice of architecture or engineering unless such services are specifically required by the Contract Documents for a portion of the Work or unless the Contractor needs to provide such services in order to carry out the Contractor's responsibilities for construction means, methods, techniques, sequences, and procedures. The Contractor shall not be required to provide professional services in violation of applicable law.

§ 3.12.10.1 If professional design services or certifications by a design professional related to systems, materials, or equipment are specifically required of the Contractor by the Contract Documents, the Owner and the Architect will specify all performance and design criteria that such services must satisfy. The Contractor shall cause such services or certifications to be provided by a properly licensed design professional, whose signature and seal shall appear on all drawings, calculations, specifications, certifications, Shop Drawings, and other submittals prepared by such professional. Shop Drawings, and other submittals related to the Work, designed or certified by such professional, if prepared by others, shall bear such professional's written approval when submitted to the Architect. The Owner and the Architect shall be entitled to rely upon the adequacy, accuracy and completeness of the services, certifications, and approvals performed or provided by such design professionals, provided the Owner and Architect have specified to the Contractor all performance and design criteria that such services must satisfy. Pursuant to this Section 3.12.10, the Architect will review, approve or take other appropriate action on submittals only for the limited purpose of checking for conformance with information given and the design concept expressed in the Contract Documents. The Contractor shall not be responsible for the adequacy of the performance and design criteria specified in the Contract Documents.

§ 3.12.10.2 If the Contract Documents require the Contractor's design professional to certify that the Work has been performed in accordance with the design criteria, the Contractor shall furnish such certifications to the Architect at the time and in the form specified by the Architect.

§ 3.13 Use of Site

The Contractor shall confine operations at the site to areas permitted by applicable laws, statutes, ordinances, codes, rules and regulations, lawful orders of public authorities, and the Contract Documents and shall not unreasonably encumber the site with materials or equipment. Contractor's use of the site shall be limited to performance of the Work.

§ 3.14 Cutting and Patching

§ 3.14.1 The Contractor shall be responsible for cutting, fitting, or patching required to complete the Work or to make its parts fit together properly. All areas requiring cutting, fitting, or patching shall be restored to the condition existing prior to the cutting, fitting, or patching, unless otherwise required by the Contract Documents.

§ 3.14.2 The Contractor shall not damage or endanger a portion of the Work or fully or partially completed construction of the Owner or Separate Contractors by cutting, patching, or otherwise altering such construction, or by excavation. The Contractor shall not cut or otherwise alter construction by the Owner or a Separate Contractor except with written consent of the Owner and of the Separate Contractor. Consent shall not be unreasonably withheld. The Contractor shall not unreasonably withhold, from the Owner or a Separate Contractor, its consent to cutting or otherwise altering the Work.

§ 3.15 Cleaning Up

§ 3.15.1 The Contractor shall at all times keep the premises and surrounding area free from accumulation of waste materials and rubbish caused by operations under the Contract. At completion of the Work, the Contractor shall remove waste materials, rubbish, the Contractor's tools, construction equipment, machinery, and surplus materials from and about the Project and leave the Work "broom clean" and ready for use.

§ 3.15.2 If the Contractor fails to clean up as provided in the Contract Documents, the Owner may do so and the Owner shall be entitled to reimbursement from the Contractor.

§ 3.15.3 The Contractor shall keep all public and Owner-owned drives and streets cleaned of spilled or tracked materials from trucking operations.

§ 3.16 Access to Work

The Contractor shall provide the Owner and Architect with access to the Work in preparation and progress wherever located.

Init.

§ 3.17 Royalties, Patents and Copyrights

The Contractor shall pay all royalties and license fees. The Contractor shall defend suits or claims for infringement of copyrights and patent rights and shall hold the Owner and Architect harmless from loss on account thereof, but shall not be responsible for defense or loss when a particular design, process, or product of a particular manufacturer or manufacturers is required by the Contract Documents, or where the copyright violations are contained in Drawings, Specifications, or other documents prepared by the Owner or Architect. However, if an infringement of a copyright or patent is discovered by, or made known to, the Contractor, the Contractor shall be responsible for the loss unless the information is promptly furnished to the Architect.

§ 3.18 Indemnification

§ 3.18.1 To the fullest extent permitted by law, the Contractor shall defend, indemnify and hold harmless the Owner, its related and affiliated foundations and entities, individually or collectively, and their respective consultants, agents and employees from and against any and all claims, damages, losses, and expenses, including but not limited to attorneys' fees, arising out of or resulting from performance of the Work, provided that such claim, damage, loss or expense is attributable to bodily injury, sickness, disease or death, or to the injury to or destruction of tangible property (other than the Work itself), including any loss of use therefrom. Contractor's obligation to defend, indemnify and hold harmless shall apply regardless of whether it is alleged that any person or entity to be indemnified hereunder, or their respective consultants, agents or employees contributed in any way to the alleged wrongdoing or are otherwise liable on account of the alleged breach of a non-delegable duty.

§ 3.18.2 In claims against any person or entity indemnified under this Section 3.18 by an employee of the Contractor, a Subcontractor, anyone directly or indirectly employed by them, or anyone for whose acts they may be liable, the indemnification obligation under Section 3.18.1 shall not be limited by a limitation on amount or type of damages, compensation, or benefits payable by or for the Contractor or a Subcontractor under workers' compensation acts, disability benefit acts, or other employee benefit acts.

ARTICLE 4 ARCHITECT

§ 4.1 General

§ 4.1.1 The Architect is the person or entity retained by the Owner pursuant to Section 2.3.2 and identified as such in the Agreement.

§ 4.1.2 Duties, responsibilities, and limitations of authority of the Architect as set forth in the Contract Documents shall not be restricted, modified, or extended without written consent of the Owner, Contractor, and Architect. Consent shall not be unreasonably withheld.

§ 4.2 Administration of the Contract

§ 4.2.1 The Architect will provide administration of the Contract as described in the Contract Documents and will be an Owner's representative during construction until the date the Architect issues the final Certificate for Payment. The Architect will have authority to act on behalf of the Owner only to the extent provided in the Contract Documents.

§ 4.2.2 The Architect will visit the site at intervals appropriate to the stage of construction, or as otherwise agreed with the Owner, to become generally familiar with the progress and quality of the portion of the Work completed, and to determine in general if the Work observed is being performed in a manner indicating that the Work, when fully completed, will be in accordance with the Contract Documents. However, the Architect will not be required to make exhaustive or continuous on-site inspections to check the quality or quantity of the Work. The Architect will not have control over, charge of, or responsibility for the construction means, methods, techniques, sequences or procedures, or for the safety precautions and programs in connection with the Work, since these are solely the Contractor's rights and responsibilities under the Contract Documents.

§ 4.2.3 On the basis of the site visits, the Architect will keep the Owner reasonably informed about the progress and quality of the portion of the Work completed, and promptly report to the Owner (1) known deviations from the Contract Documents, (2) known deviations from the most recent construction schedule submitted by the Contractor, and (3) defects and deficiencies observed in the Work. The Architect will not be responsible for the Contractor's failure to perform the Work in accordance with the requirements of the Contract Documents. The Architect will not have control over or charge of, and will not be responsible for acts or omissions of, the Contractor, Subcontractors, or their agents or employees, or any other persons or entities performing portions of the Work.

Init.

§ 4.2.4 Communications

The Owner and Contractor shall include the Architect in all communications that materially affect the Architect's services or professional responsibilities. The Owner shall promptly notify the Architect of the substance of any direct communications between the Owner and the Contractor otherwise relating to the Project. Communications by and with the Architect's consultants shall be through the Architect. Communications by and with Subcontractors and suppliers shall be through the Contractor. Communications by and with Separate Contractors shall be through the Owner. The Contract Documents may specify other communication protocols.

§ 4.2.5 Based on the Architect's evaluations of the Contractor's Applications for Payment, the Architect will review and certify the amounts due the Contractor and will issue Certificates for Payment in such amounts.

§ 4.2.6 The Architect has authority to reject Work that does not conform to the Contract Documents. Whenever the Architect considers it necessary or advisable, the Architect will have authority to require inspection or testing of the Work in accordance with Sections 13.4.2 and 13.4.3, whether or not the Work is fabricated, installed or completed. However, neither this authority of the Architect nor a decision made in good faith either to exercise or not to exercise such authority shall give rise to a duty or responsibility of the Architect to the Contractor, Subcontractors, suppliers, their agents or employees, or other persons or entities performing portions of the Work.

§ 4.2.7 The Architect will review and approve, or take other appropriate action upon, the Contractor's submittals such as Shop Drawings, Product Data, and Samples, but only for the limited purpose of checking for conformance with information given and the design expressed in the Contract Documents. The Architect's action will be taken in accordance with the submittal schedule approved by the Architect with reasonable promptness while allowing sufficient time in the Architect's professional judgment to permit adequate review. Review of such submittals is not conducted for the purpose of determining the accuracy and completeness of other details such as dimensions and quantities, or for substantiating instructions for installation or performance of equipment or systems, all of which remain the responsibility of the Contractor as required by the Contract Documents. The Architect's review of the Contractor's submittals shall not relieve the Contractor of the obligations under Sections 3.3, 3.5, and 3.12. The Architect's review shall not constitute approval of safety precautions or, unless otherwise specifically stated by the Architect, of any construction means, methods, techniques, sequences, or procedures. The Architect's approval of a specific item shall not indicate approval of an assembly of which the item is a component.

§ 4.2.8 The Architect will prepare Change Orders and Construction Change Directives, and may order minor changes in the Work as provided in Section 7.4. The Architect will investigate and make determinations and recommendations regarding concealed and unknown conditions as provided in Section 3.7.4.

§ 4.2.9 The Architect will conduct inspections to determine the date or dates of Substantial Completion and the date of final completion; issue Certificates of Substantial Completion pursuant to Section 9.8; receive and forward to the Owner, for the Owner's review and records, written warranties and related documents required by the Contract and assembled by the Contractor pursuant to Section 9.10; and issue a final Certificate for Payment pursuant to Section 9.10.

§ 4.2.10 If the Owner and Architect agree, the Architect will provide one or more Project representatives to assist in carrying out the Architect's responsibilities at the site. The Owner shall notify the Contractor of any change in the duties, responsibilities and limitations of authority of the Project representatives.

§ 4.2.11 The Architect will interpret and decide matters concerning performance under, and requirements of, the Contract Documents on written request of either the Owner or Contractor. The Architect's response to such requests will be made in writing within any time limits agreed upon or otherwise with reasonable promptness.

§ 4.2.12 Interpretations and decisions of the Architect will be consistent with the intent of, and reasonably inferable from, the Contract Documents and will be in writing or in the form of drawings. When making such interpretations and decisions, the Architect will endeavor to secure faithful performance by both Owner and Contractor, will not show partiality to either, and will not be liable for results of interpretations or decisions rendered in good faith.

§ 4.2.13 The Architect's decisions on matters relating to aesthetic effect will be final if consistent with the intent expressed in the Contract Documents.

Init.

§ 4.2.14 The Architect will review and respond to requests for information about the Contract Documents. The Architect's response to such requests will be made in writing within any time limits agreed upon or otherwise with reasonable promptness. If appropriate, the Architect will prepare and issue supplemental Drawings and Specifications in response to the requests for information.

ARTICLE 5 SUBCONTRACTORS

§ 5.1 Definitions

§ 5.1.1 A Subcontractor is a person or entity who has a direct contract with the Contractor to perform a portion of the Work at the site. The term "Subcontractor" is referred to throughout the Contract Documents as if singular in number and means a Subcontractor or an authorized representative of the Subcontractor. The term "Subcontractor" does not include a Separate Contractor or the subcontractors of a Separate Contractor.

§ 5.1.2 A Sub-subcontractor is a person or entity who has a direct or indirect contract with a Subcontractor to perform a portion of the Work at the site. The term "Sub-subcontractor" is referred to throughout the Contract Documents as if singular in number and means a Sub-subcontractor or an authorized representative of the Sub-subcontractor.

§ 5.2 Award of Subcontracts and Other Contracts for Portions of the Work

§ 5.2.1 Unless otherwise stated in the Contract Documents or the bidding requirements, the Contractor, as soon as practicable after award of the Contract, shall notify the Owner and Architect of the persons or entities proposed for each principal portion of the Work, including those who are to furnish materials or equipment fabricated to a special design. Within 14 days of receipt of the information, the Architect may notify the Contractor whether the Owner or the Architect (1) has reasonable objection to any such proposed person or entity or (2) requires additional time for review. Failure of the Architect to provide notice within the 14-day period shall constitute notice of no reasonable objection.

§ 5.2.2 The Contractor shall not contract with a proposed person or entity to whom the Owner or Architect has made reasonable and timely objection. The Contractor shall not be required to contract with anyone to whom the Contractor has made reasonable objection.

§ 5.2.3 If the Owner or Architect has reasonable objection to a person or entity proposed by the Contractor, the Contractor shall propose another to whom the Owner or Architect has no reasonable objection.

§ 5.2.4 The Contractor shall not substitute a Subcontractor, person, or entity for one previously selected if the Owner or Architect makes reasonable objection to such substitution.

§ 5.3 Subcontractual Relations

By appropriate written agreement, the Contractor shall require each Subcontractor, to the extent of the Work to be performed by the Subcontractor, to be bound to the Contractor by terms of the Contract Documents, and to assume toward the Contractor all the obligations and responsibilities, including the responsibility for safety of the Subcontractor's Work that the Contractor, by these Contract Documents, assumes toward the Owner and Architect. Each subcontract agreement shall preserve and protect the rights of the Owner and Architect under the Contract Documents with respect to the Work to be performed by the Subcontractor so that subcontracting thereof will not prejudice such rights, and shall allow to the Subcontractor, unless specifically provided otherwise in the subcontract agreement, the benefit of all rights, remedies, and redress against the Contractor that the Contractor, by the Contract Documents, has against the Owner. Where appropriate, the Contractor shall require each Subcontractor to enter into similar agreements with Sub-subcontractors. The Contractor shall make available to each proposed Subcontractor, prior to the execution of the subcontract agreement, copies of the Contract Documents to which the Subcontractor will be bound, and, upon written request of the Subcontractor, identify to the Subcontractor terms and conditions of the proposed subcontract agreement that may be at variance with the Contract Documents. Subcontractors will similarly make copies of applicable portions of such documents available to their respective proposed Sub-subcontractors.

§ 5.3.1 Contractor shall comply with all statutory provisions regarding the payment of Subcontractors, including but not limited to I.C. §5-16-5.5-6 or its equivalent.

§ 5.4 Contingent Assignment of Subcontracts

§ 5.4.1 Each subcontract agreement for a portion of the Work is assigned by the Contractor to the Owner, provided that

- .1 assignment is effective only after termination of the Contract by the Owner for cause pursuant to Section 14.2 and only for those subcontract agreements that the Owner accepts by notifying the Subcontractor and Contractor; and
- .2 assignment is subject to the prior rights of the surety, if any, obligated under bond relating to the Contract.

When the Owner accepts the assignment of a subcontract agreement, the Owner assumes the Contractor's rights and obligations under the subcontract.

§ 5.4.2 Upon such assignment, if the Work has been suspended for more than 30 days, the Subcontractor's compensation shall be equitably adjusted for increases in cost resulting from the suspension.

§ 5.4.3 Upon assignment to the Owner under this Section 5.4, the Owner may further assign the subcontract to a successor contractor or other entity. If the Owner assigns the subcontract to a successor contractor or other entity, the Owner shall nevertheless remain legally responsible for all of the successor contractor's obligations under the subcontract.

ARTICLE 6 CONSTRUCTION BY OWNER OR BY SEPARATE CONTRACTORS

§ 6.1 Owner's Right to Perform Construction and to Award Separate Contracts

§ 6.1.1 The term "Separate Contractor(s)" shall mean other contractors retained by the Owner under separate agreements. The Owner reserves the right to perform construction or operations related to the Project with the Owner's own forces, and with Separate Contractors retained under Conditions of the Contract substantially similar to those of this Contract, including those provisions of the Conditions of the Contract related to insurance and waiver of subrogation.

§ 6.1.2 When separate contracts are awarded for different portions of the Project or other construction or operations on the site, the term "Contractor" in the Contract Documents in each case shall mean the Contractor who executes each separate Owner-Contractor Agreement.

§ 6.1.3 The Owner shall provide for coordination of the activities of the Owner's own forces and of each Separate Contractor with the Work of the Contractor, who shall cooperate with them. The Contractor shall participate with any Separate Contractors and the Owner in reviewing their construction schedules. The Contractor shall make any revisions to its construction schedule deemed necessary after a joint review and mutual agreement. The construction schedules shall then constitute the schedules to be used by the Contractor, Separate Contractors, and the Owner until subsequently revised.

§ 6.1.4 Unless otherwise provided in the Contract Documents, when the Owner performs construction or operations related to the Project with the Owner's own forces or with Separate Contractors, the Owner or its Separate Contractors shall have the same obligations and rights that the Contractor has under the Conditions of the Contract, including, without excluding others, those stated in Article 3, this Article 6, and Articles 10, 11, and 12.

§ 6.2 Mutual Responsibility

§ 6.2.1 The Contractor shall afford the Owner and Separate Contractors reasonable opportunity for introduction and storage of their materials and equipment and performance of their activities, and shall connect and coordinate the Contractor's construction and operations with theirs as required by the Contract Documents.

§ 6.2.2 If part of the Contractor's Work depends for proper execution or results upon construction or operations by the Owner or a Separate Contractor, the Contractor shall, prior to proceeding with that portion of the Work, promptly notify the Architect of apparent discrepancies or defects in the construction or operations by the Owner or Separate Contractor that would render it unsuitable for proper execution and results of the Contractor's Work. Failure of the Contractor to notify the Architect of apparent discrepancies or defects prior to proceeding with the Work shall constitute an acknowledgment that the Owner's or Separate Contractor's completed or partially completed construction is fit and proper to receive the Contractor's Work. The Contractor shall not be responsible for discrepancies or defects in the construction or operations by the Owner or Separate Contractor that are not apparent.

§ 6.2.3 The Contractor shall reimburse the Owner for costs the Owner incurs that are payable to a Separate Contractor because of the Contractor's delays, improperly timed activities or defective construction. The Owner shall be

responsible to the Contractor for costs the Contractor incurs because of a Separate Contractor's delays, improperly timed activities, damage to the Work or defective construction.

§ 6.2.4 The Contractor shall promptly remedy damage that the Contractor wrongfully causes to completed or partially completed construction or to property of the Owner or Separate Contractor as provided in Section 10.2.5.

§ 6.2.5 The Owner and each Separate Contractor shall have the same responsibilities for cutting and patching as are described for the Contractor in Section 3.14.

§ 6.3 Owner's Right to Clean Up

If a dispute arises among the Contractor, Separate Contractors, and the Owner as to the responsibility under their respective contracts for maintaining the premises and surrounding area free from waste materials and rubbish, the Owner may clean up and the Architect will allocate the cost among those responsible.

ARTICLE 7 CHANGES IN THE WORK

§ 7.1 General

§ 7.1.1 Changes in the Work may be accomplished after execution of the Contract, and without invalidating the Contract, by Change Order, Construction Change Directive or order for a minor change in the Work, subject to the limitations stated in this Article 7 and elsewhere in the Contract Documents.

§ 7.1.2 A Change Order shall be based upon agreement among the Owner, Contractor, and Architect. A Construction Change Directive requires agreement by the Owner and Architect and may or may not be agreed to by the Contractor. An order for a minor change in the Work may be issued by the Architect alone.

§ 7.1.3 Changes in the Work shall be performed under applicable provisions of the Contract Documents. The Contractor shall proceed promptly with changes in the Work, unless otherwise provided in the Change Order, Construction Change Directive, or order for a minor change in the Work. Except as permitted in Section 7.3, a change in the Contract Sum or the Contract Time shall be accomplished only by Change Order. Accordingly, no course of conduct or dealing between the parties, nor express or implied acceptance of alterations or addition to the Work, and no claim that the Owner has been unjustly enriched by any alteration of or addition to the Work, shall be the basis of any claim to an increase in any amounts due under the Contract Documents or a change in any time period provided for in the Contract Documents.

§ 7.1.4 A change in the Contract Sum or the Contract Time may only be accomplished through a Change Order or a Construction Change Directive. No course of dealing, express or implied acceptance of alterations or additions to the Work, or claim that the Owner has been unjustly enriched by an alteration or addition to the Work shall entitle the Contractor to an increase in the Contract Sum or the Contract Time.

§ 7.1.5 If the Contractor claims that any instructions, by drawings or otherwise, involve extra cost under this Contract, Contractor shall provide the Architect and Owner with Written Notice in accordance with the requirements of Article 15 before proceeding to execute the work. The timely giving of such Written Notice shall constitute a condition precedent to the Contractor's entitlement to compensation for such extra costs. Failure of the Contractor to give such Written Notice shall also constitute a waiver of any such claim for extra compensation.

§ 7.2 Change Orders

§ 7.2.1 A Change Order is a written instrument prepared by the Architect and signed by the Owner, Contractor, and Architect stating their agreement upon all of the following:

- .1 The change in the Work;
- .2 The amount of the adjustment, if any, in the Contract Sum; and
- .3 The extent of the adjustment, if any, in the Contract Time.

§ 7.2.2 An executed Change Order shall become an amendment to the Contract Documents and all provisions of the Contract Documents shall apply thereto. In consideration of the Change Order as a complete equitable adjustment, the Contractor releases the Owner of and from any and all costs, expenses, damages or claims attributable in whole or in part to:

- .1 The facts and circumstances giving rise to the Change Order; and
- .2 The execution of the Change Order.

Init.

§ 7.2.3 For any adjustments in the Contract Sum, the Contractor overhead and profit shall be calculated as follows:

- .1 Cost of labor payroll, not to exceed the actual wages paid on this project, plus applicable payroll taxes and insurance, plus 10%; Costs of the material, including rentals, plus 10%.
- .2 For work by Subcontractors, or a lower tier Contractor, the Contractor performing the Work shall be permitted to mark up its costs in accordance with Section 7.2.3.1, and each succeeding Contractor, including the Prime Contractor, shall add 10%.

§ 7.3 Construction Change Directives

§ 7.3.1 A Construction Change Directive is a written order prepared by the Architect and signed by the Owner and Architect, directing a change in the Work prior to agreement on adjustment, if any, in the Contract Sum or Contract Time, or both. The Owner may by Construction Change Directive, without invalidating the Contract, order changes in the Work within the general scope of the Contract consisting of additions, deletions, or other revisions, the Contract Sum and Contract Time being adjusted accordingly.

§ 7.3.2 A Construction Change Directive shall be used in the absence of total agreement on the terms of a Change Order.

§ 7.3.3 If the Construction Change Directive provides for an adjustment to the Contract Sum, the adjustment shall be based on one of the following methods:

- .1 Mutual acceptance of a lump sum properly itemized and supported by sufficient substantiating data to permit evaluation;
- .2 Unit prices stated in the Contract Documents or subsequently agreed upon;
- .3 Cost to be determined in a manner agreed upon by the parties and a mutually acceptable fixed or percentage fee; or
- .4 As provided in Section 7.3.4.

§ 7.3.4 If the Contractor does not respond promptly or disagrees with the method for adjustment in the Contract Sum, the Architect shall determine the adjustment on the basis of reasonable expenditures and savings of those performing the Work attributable to the change, including, in case of an increase in the Contract Sum, an amount for overhead and profit as set forth in the Agreement, or if no such amount is set forth in the Agreement, a reasonable amount. In such case, and also under Section 7.3.3.3, the Contractor shall keep and present, in such form as the Architect may prescribe, an itemized accounting together with appropriate supporting data. Unless otherwise provided in the Contract Documents, costs for the purposes of this Section 7.3.4 shall be limited to the following:

- .1 Costs of labor, including applicable payroll taxes, fringe benefits required by agreement or custom, workers' compensation insurance, and other employee costs approved by the Architect;
- .2 Costs of materials, supplies, and equipment, including cost of transportation, whether incorporated or consumed;
- .3 Rental costs of machinery and equipment, exclusive of hand tools, whether rented from the Contractor or others;
- .4 Costs of premiums for all bonds and insurance, permit fees, and sales, use, or similar taxes, directly related to the change; and
- .5 Costs of supervision and field office personnel directly attributable to the change.

§ 7.3.5 If the Contractor disagrees with the adjustment in the Contract Time, the Contractor may make a Claim in accordance with applicable provisions of Article 15.

§ 7.3.6 Upon receipt of a Construction Change Directive, the Contractor shall promptly proceed with the change in the Work involved and advise the Architect of the Contractor's agreement or disagreement with the method, if any, provided in the Construction Change Directive for determining the proposed adjustment in the Contract Sum or Contract Time.

§ 7.3.7 A Construction Change Directive signed by the Contractor indicates the Contractor's agreement therewith, including adjustment in Contract Sum and Contract Time or the method for determining them. Such agreement shall be effective immediately and shall be recorded as a Change Order.

§ 7.3.8 The amount of credit to be allowed by the Contractor to the Owner for a deletion or change that results in a net decrease in the Contract Sum shall be actual net cost as confirmed by the Architect. When both additions and credits covering related Work or substitutions are involved in a change, the allowance for overhead and profit shall be figured on the basis of net increase, if any, with respect to that change.

§ 7.3.9 Deleted

§ 7.3.10 When the Owner and Contractor agree with a determination made by the Architect concerning the adjustments in the Contract Sum and Contract Time, or otherwise reach agreement upon the adjustments, such agreement shall be effective immediately and the Architect will prepare a Change Order. Change Orders may be issued for all or any part of a Construction Change Directive.

§ 7.4 Minor Changes in the Work

The Architect may order minor changes in the Work that are consistent with the intent of the Contract Documents and do not involve an adjustment in the Contract Sum or an extension of the Contract Time. The Architect's order for minor changes shall be in writing. If the Contractor believes that the proposed minor change in the Work will affect the Contract Sum or Contract Time, the Contractor shall notify the Architect and shall not proceed to implement the change in the Work. If the Contractor performs the Work set forth in the Architect's order for a minor change without prior notice to the Architect that such change will affect the Contract Sum or Contract Time, the Contractor waives any adjustment to the Contract Sum or extension of the Contract Time.

ARTICLE 8 TIME

§ 8.1 Definitions

§ 8.1.1 Unless otherwise provided, Contract Time is the period of time, including authorized adjustments, allotted in the Contract Documents for Substantial Completion of the Work.

§ 8.1.2 The date of commencement of the Work is the date established in the Agreement.

§ 8.1.3 The date of Substantial Completion is the date certified by the Architect in accordance with Section 9.8.

§ 8.1.4 The term "day" as used in the Contract Documents shall mean calendar day unless otherwise specifically defined.

§ 8.2 Progress and Completion

§ 8.2.1 Time limits stated in the Contract Documents are of the essence of the Contract. By executing the Agreement, the Contractor confirms that the Contract Time is a reasonable period for performing the Work.

§ 8.2.2 The Contractor shall not knowingly, except by agreement or instruction of the Owner in writing, commence the Work prior to the effective date of insurance required to be furnished by the Contractor and Owner.

§ 8.2.3 The Contractor shall proceed expeditiously with adequate forces and shall achieve Substantial Completion within the Contract Time.

§ 8.3 Delays and Extensions of Time

§ 8.3.1 If the Contractor is delayed at any time in the commencement or progress of the Work by an act or neglect of the Owner or Architect, or of an employee of either, or of a Separate Contractor employed by the Owner; or by changes ordered in the Work; or by labor disputes not caused by wrongful or unlawful acts of Contractor, fire, unusual delay in deliveries, unavoidable casualties or other causes beyond the Contractor's control ("Excusable Delay"), then the Contract Time shall be extended by Change Order for a period of time equal to the duration of the Excusable Delay.

§ 8.3.2 Claims relating to time shall be made in accordance with applicable provisions of Article 15.

§ 8.3.3 Except as provided in Sections 3.7.4 and 10.3.3, an extension of time for Excusable Delay, as defined above, shall be the Contractor's exclusive remedy in the event of such a delay, no matter how or by whom caused.

Contractor further specifically acknowledges that it shall have no claim for increase in the Contract Sum or damages of any kind because of any delays whatsoever to all or any part of the Work whether foreseen or unforeseen, and whether caused by any person's hindrance or active interference.

ARTICLE 9 PAYMENTS AND COMPLETION

§ 9.1 Contract Sum

§ 9.1.1 The Contract Sum is stated in the Agreement and, including authorized adjustments, is the total amount payable by the Owner to the Contractor for performance of the Work under the Contract Documents.

§ 9.1.2 If unit prices are stated in the Contract Documents or subsequently agreed upon, and if quantities originally contemplated are materially changed in a proposed Change Order or Construction Change Directive so that application of such unit prices to quantities of Work proposed will cause substantial inequity to the Owner or Contractor, the applicable unit prices shall be equitably adjusted. Unit prices include Contractor's overhead and profit.

§ 9.2 Schedule of Values

Where the Contract is based on a stipulated sum or Guaranteed Maximum Price, the Contractor shall submit a schedule of values to the Architect before the first Application for Payment, allocating the entire Contract Sum to the various portions of the Work. The schedule of values shall be prepared in the form, and supported by the data to substantiate its accuracy, required by the Architect. This schedule, unless objected to by the Architect, shall be used as a basis for reviewing the Contractor's Applications for Payment. Any changes to the schedule of values shall be submitted to the Architect and supported by such data to substantiate its accuracy as the Architect may require, and unless objected to by the Architect, shall be used as a basis for reviewing the Contractor's subsequent Applications for Payment.

§ 9.3 Applications for Payment

§ 9.3.1 At least ten days before the date established for each progress payment, the Contractor shall submit to the Architect an itemized Application for Payment prepared in accordance with the schedule of values, if required under Section 9.2, for completed portions of the Work. The application shall be notarized, if required, and supported by all data substantiating the Contractor's right to payment that the Owner or Architect require, such as copies of requisitions, and releases and waivers of liens from Subcontractors and suppliers, and shall reflect retainage if provided for in the Contract Documents.

§ 9.3.1.1 Deleted

§ 9.3.1.2 Applications for Payment shall not include requests for payment for portions of the Work for which the Contractor does not intend to pay a Subcontractor or supplier, unless such Work has been performed by others whom the Contractor intends to pay.

§ 9.3.2 Unless otherwise provided in the Contract Documents, payments shall be made on account of materials and equipment delivered and suitably stored at the site for subsequent incorporation in the Work. If approved in advance by the Owner, payment may similarly be made for materials and equipment suitably stored off the site at a location agreed upon in writing. Payment for materials and equipment stored on or off the site shall be conditioned upon compliance by the Contractor with procedures satisfactory to the Owner to establish the Owner's title to such materials and equipment or otherwise protect the Owner's interest, and shall include the costs of applicable insurance, storage, and transportation to the site, for such materials and equipment stored off the site.

§ 9.3.3 The Contractor warrants that title to all Work covered by an Application for Payment will pass to the Owner no later than the time of payment. The Contractor further warrants that upon submittal of an Application for Payment all Work for which Certificates for Payment have been previously issued and payments received from the Owner shall, to the best of the Contractor's knowledge, information, and belief, be free and clear of liens, claims, security interests, or encumbrances, in favor of the Contractor, Subcontractors, suppliers, or other persons or entities that provided labor, materials, and equipment relating to the Work.

§ 9.3.4 The Contractor's final Application for Payment shall contain evidence satisfactory to the Architect and the Owner that all payrolls, material bills, and other indebtedness connected with the Work has been paid. The final Application for Payment shall be accompanied by the Contractor's Compliance Affidavit, Contractor's Affidavit,

Init.

Waiver of Claims and Liens, and Guarantee in the form included in the Specifications properly completed and executed by the Contractor, each of the Contractor's Subcontractors, and by each of Contractor's major material suppliers.

§ 9.4 Certificates for Payment

§ 9.4.1 The Architect will, within seven days after receipt of the Contractor's Application for Payment, either (1) issue to the Owner a Certificate for Payment in the full amount of the Application for Payment, with a copy to the Contractor; or (2) issue to the Owner a Certificate for Payment for such amount as the Architect determines is properly due, and notify the Contractor and Owner of the Architect's reasons for withholding certification in part as provided in Section 9.5.1; or (3) withhold certification of the entire Application for Payment, and notify the Contractor and Owner of the Architect's reason for withholding certification in whole as provided in Section 9.5.1.

§ 9.4.2 The issuance of a Certificate for Payment will constitute a representation by the Architect to the Owner, based on the Architect's evaluation of the Work and the data in the Application for Payment, that, to the best of the Architect's knowledge, information, and belief, the Work has progressed to the point indicated, the quality of the Work is in accordance with the Contract Documents, and that the Contractor is entitled to payment in the amount certified. The foregoing representations are subject to an evaluation of the Work for conformance with the Contract Documents upon Substantial Completion, to results of subsequent tests and inspections, to correction of minor deviations from the Contract Documents prior to completion, and to specific qualifications expressed by the Architect. However, the issuance of a Certificate for Payment will not be a representation that the Architect has (1) made exhaustive or continuous on-site inspections to check the quality or quantity of the Work; (2) reviewed construction means, methods, techniques, sequences, or procedures; (3) reviewed copies of requisitions received from Subcontractors and suppliers and other data requested by the Owner to substantiate the Contractor's right to payment; or (4) made examination to ascertain how or for what purpose the Contractor has used money previously paid on account of the Contract Sum.

§ 9.4.3 Upon receipt of Architect's Certificate for Payment the Owner will, within 14 days, either issue payment to the Contractor in the amount of the Certification or make such payment as is undisputed and offer explanation of the disputed items. When the reasons for withholding are removed, payment will be made for amounts withheld.

§ 9.5 Decisions to Withhold Certification

§ 9.5.1 The Architect may withhold a Certificate for Payment in whole or in part, to the extent reasonably necessary to protect the Owner, if in the Architect's opinion the representations to the Owner required by Section 9.4.2 cannot be made. If the Architect is unable to certify payment in the amount of the Application, the Architect will notify the Contractor and Owner as provided in Section 9.4.1. If the Contractor and Architect cannot agree on a revised amount, the Architect will promptly issue a Certificate for Payment for the amount for which the Architect is able to make such representations to the Owner. The Architect may also withhold a Certificate for Payment or, because of subsequently discovered evidence, may nullify the whole or a part of a Certificate for Payment previously issued, to such extent as may be necessary in the Architect's opinion to protect the Owner from loss for which the Contractor is responsible, including loss resulting from acts and omissions described in Section 3.3.2, because of

- .1 defective Work not remedied;
- .2 third party claims filed or reasonable evidence indicating probable filing of such claims, unless security acceptable to the Owner is provided by the Contractor;
- .3 failure of the Contractor to make payments properly to Subcontractors or suppliers for labor, materials or equipment;
- .4 reasonable evidence that the Work cannot be completed for the unpaid balance of the Contract Sum;
- .5 damage to the Owner or a Separate Contractor;
- .6 reasonable evidence that the Work will not be completed within the Contract Time, and that the unpaid balance would not be adequate to cover actual or liquidated damages for the anticipated delay;
- .7 repeated failure to carry out the Work in accordance with the Contract Documents; or
- .8 failure to defend, indemnify or hold harmless the Owner and other required indemnitees as required by the Contract Documents.

§ 9.5.2 When either party disputes the Architect's decision regarding a Certificate for Payment under Section 9.5.1, in whole or in part, that party may submit a Claim in accordance with Article 15.

§ 9.5.3 When the reasons for withholding certification are removed, certification will be made for amounts previously withheld.

§ 9.5.4 If the Architect withholds certification for payment under Section 9.5.1.3, the Owner may, at its sole option, issue joint checks to the Contractor and to any Subcontractor or supplier to whom the Contractor failed to make payment for Work properly performed or material or equipment suitably delivered. If the Owner makes payments by joint check, the Owner shall notify the Architect and the Contractor shall reflect such payment on its next Application for Payment.

§ 9.6 Progress Payments

§ 9.6.1 After the Architect has issued a Certificate for Payment, the Owner shall make payment in the manner and within the time provided in the Contract Documents, and shall so notify the Architect.

§ 9.6.2 The Contractor shall pay each Subcontractor, no later than seven days after receipt of payment from the Owner, the amount to which the Subcontractor is entitled, reflecting percentages actually retained from payments to the Contractor on account of the Subcontractor's portion of the Work. The Contractor shall, by appropriate agreement with each Subcontractor, require each Subcontractor to make payments to Sub-subcontractors in a similar manner.

§ 9.6.3 The Architect will, on request, furnish to a Subcontractor, if practicable, information regarding percentages of completion or amounts applied for by the Contractor and action taken thereon by the Architect and Owner on account of portions of the Work done by such Subcontractor.

§ 9.6.4 The Owner has the right to request written evidence from the Contractor that the Contractor has properly paid Subcontractors and suppliers amounts paid by the Owner to the Contractor for subcontracted Work. If the Contractor fails to furnish such evidence within seven days, the Owner shall have the right to contact Subcontractors and suppliers to ascertain whether they have been properly paid. Neither the Owner nor Architect shall have an obligation to pay, or to see to the payment of money to, a Subcontractor or supplier, except as may otherwise be required by law.

§ 9.6.5 The Contractor's payments to suppliers shall be treated in a manner similar to that provided in Sections 9.6.2, 9.6.3 and 9.6.4.

§ 9.6.6 A Certificate for Payment, a progress payment, or partial or entire use or occupancy of the Project by the Owner shall not constitute acceptance of Work not in accordance with the Contract Documents.

§ 9.6.7 Deleted

§ 9.6.8 Provided the Owner has fulfilled its payment obligations under the Contract Documents, the Contractor shall defend and indemnify the Owner from all loss, liability, damage or expense, including reasonable attorney's fees and litigation expenses, arising out of any lien claim or other claim for payment by any Subcontractor or supplier of any tier. Upon receipt of notice of a lien claim or other claim for payment, the Owner shall notify the Contractor. If approved by the applicable court, when required, the Contractor may substitute a surety bond for the property against which the lien or other claim for payment has been asserted.

§ 9.7 Failure of Payment

§ 9.7.1 A final Certificate for Payment shall not be issued until all labor and materials required in the Contract Documents have been furnished, installed and completed, all claims have been disposed of and all claims for extra work materials and allowances for omissions have been rendered, considered and, if agreed to, made a part of such Certificate of Payment.

§ 9.7.2 If, pursuant to the Contract Documents, the Owner is entitled to any reimbursement or payment from the Contractor, Contractor shall make such payment within 14 days of demand by the Owner. Notwithstanding anything in the Contract Documents to the contrary, if Contractor fails to make any payment due the Owner, or if the Owner incurs any costs and expenses to cure any default of Contractor or to correct defective Work, the Owner shall have the right to either (1) deduct an amount equal to that which the Owner is entitled from any payment then or thereafter due Contractor from the Owner, or (2) issue a written notice to the Contractor reducing the Contract Sum by an amount equal to that which the Owner is entitled.

§ 9.8 Substantial Completion

§ 9.8.1 Substantial Completion is the stage in the progress of the Work when:

- .1 The Work or designated portion thereof is sufficiently complete in accordance with the Contract Documents so that the Owner can occupy or utilize the Work for its intended use; and
- .2 The Owner has received from any governmental authority having jurisdictional authority thereof all certificates of occupancy and all other permits, approvals, licenses or other documents necessary for the beneficial occupancy of the Project.

§ 9.8.2 When the Contractor considers that the Work, or a portion thereof which the Owner agrees to accept separately, is substantially complete, the Contractor shall prepare and submit to the Architect a comprehensive list of items to be completed or corrected prior to final payment. Failure to include an item on such list does not alter the responsibility of the Contractor to complete all Work in accordance with the Contract Documents.

§ 9.8.3 Upon receipt of the Contractor's list, the Architect and Owner will make an inspection to determine whether the Work or designated portion thereof is substantially complete. If the inspection discloses any item, whether or not included on the Contractor's list, which is not sufficiently complete in accordance with the Contract Documents so that the Owner can occupy or utilize the Work or designated portion thereof for its intended use, the Contractor shall, before issuance of the Certificate of Substantial Completion, complete or correct such item upon notification by the Architect. In such case, the Contractor shall then submit a request for another inspection by the Architect to determine Substantial Completion.

§ 9.8.4 When the Work or designated portion thereof is substantially complete, the Architect will prepare a Certificate of Substantial Completion that shall establish the date of Substantial Completion; establish responsibilities of the Owner and Contractor for security, maintenance, heat, utilities, damage to the Work and insurance; and fix the time within which the Contractor shall finish all items on the list accompanying the Certificate. Warranties required by the Contract Documents shall commence on the date of Substantial Completion of the Work or designated portion thereof unless otherwise provided in the Certificate of Substantial Completion.

§ 9.8.5 The Certificate of Substantial Completion shall be submitted to the Owner and Contractor for their written acceptance of responsibilities assigned to them in the Certificate. Upon such acceptance, and consent of surety if any, the Owner shall make payment of retainage applying to the Work or designated portion thereof. Such payment shall be adjusted for Work that is incomplete or not in accordance with the requirements of the Contract Documents.

§ 9.9 Partial Occupancy or Use

§ 9.9.1 The Owner may occupy or use any completed or partially completed portion of the Work at any stage when such portion is designated by separate agreement with the Contractor. Such partial occupancy or use may commence whether or not the portion is substantially complete, provided the Owner and Contractor have accepted in writing the responsibilities assigned to each of them for payments, retainage, security, maintenance, heat, utilities, damage to the Work and insurance, and have agreed in writing concerning the period for correction of the Work and commencement of warranties required by the Contract Documents. When the Contractor considers a portion substantially complete, the Contractor shall prepare and submit a list to the Architect as provided under Section 9.8.2. Consent of the Contractor to partial occupancy or use shall not be unreasonably withheld. The stage of the progress of the Work shall be determined by written agreement between the Owner and Contractor or, if no agreement is reached, by decision of the Architect.

§ 9.9.2 Immediately prior to such partial occupancy or use, the Owner, Contractor, and Architect shall jointly inspect the area to be occupied or portion of the Work to be used in order to determine and record the condition of the Work.

§ 9.9.3 Unless otherwise agreed upon, partial occupancy or use of a portion or portions of the Work shall not constitute acceptance of Work not complying with the requirements of the Contract Documents or a waiver of any right under the Contract Documents.

§ 9.10 Final Completion and Final Payment

§ 9.10.1 Upon receipt of the Contractor's notice that the Work is ready for final inspection and acceptance and upon receipt of a final Application for Payment, the Architect will promptly make such inspection. When the Architect finds the Work acceptable under the Contract Documents and the Contract fully performed, the Architect will promptly

issue a final Certificate for Payment stating that to the best of the Architect's knowledge, information and belief, and on the basis of the Architect's on-site visits and inspections, the Work has been completed in accordance with the Contract Documents and that the entire balance found to be due the Contractor and noted in the final Certificate is due and payable. The Architect's final Certificate for Payment will constitute a further representation that conditions listed in Section 9.10.2 as precedent to the Contractor's being entitled to final payment have been fulfilled.

§ 9.10.2 Neither final payment nor any remaining retained percentage shall become due until the Contractor submits to the Architect (1) an affidavit that payrolls, bills for materials and equipment, and other indebtedness connected with the Work for which the Owner or the Owner's property might be responsible or encumbered (less amounts withheld by Owner) have been paid or otherwise satisfied, (2) a certificate evidencing that insurance required by the Contract Documents to remain in force after final payment is currently in effect and will not be canceled or allowed to expire until at least 30 days' prior written notice has been given to the Owner, (3) a written statement that the Contractor knows of no substantial reason that the insurance will not be renewable to cover the period required by the Contract Documents, (4) consent of surety to final payment (5), if required by the Owner, other data establishing payment or satisfaction of obligations, such as receipts, releases and waivers of liens, claims, security interests or encumbrances arising out of the Contract, to the extent and in such form as may be designated by the Owner, and (6) all "As Built" drawings, complete operating instructions for equipment and accessories, maintenance manuals, documentation of any special warranties, such as manufacturers' warranties or specific subcontractor warranties, and bonds, certificates and guarantees required by the Contract Documents.

§ 9.10.3 If, after Substantial Completion of the Work, final completion thereof is materially delayed through no fault of the Contractor or by issuance of Change Orders affecting final completion, and the Architect so confirms, the Owner shall, upon application by the Contractor and certification by the Architect, and without terminating the Contract, make payment of the balance due for that portion of the Work fully completed, corrected, and accepted. If the remaining balance for Work not fully completed or corrected is less than retainage stipulated in the Contract Documents, and if bonds have been furnished, the written consent of the surety to payment of the balance due for that portion of the Work fully completed and accepted shall be submitted by the Contractor to the Architect prior to certification of such payment. Such payment shall be made under terms and conditions governing final payment, except that it shall not constitute a waiver of Claims.

§ 9.10.4 The making of final payment shall constitute a waiver of Claims by the Owner except those arising from

- .1 liens, Claims, security interests, or encumbrances arising out of the Contract and unsettled;
- .2 failure of the Work to comply with the requirements of the Contract Documents;
- .3 terms of special warranties required by the Contract Documents; or
- .4 audits performed by the Owner, if permitted by the Contract Documents, after final payment.

§ 9.10.5 Acceptance of final payment by the Contractor, a Subcontractor, or a supplier, shall constitute a waiver of claims by that payee except those previously made in writing and identified by that payee as unsettled at the time of final Application for Payment.

ARTICLE 10 PROTECTION OF PERSONS AND PROPERTY

§ 10.1 Safety Precautions and Programs

The Contractor shall be responsible for initiating, maintaining, and supervising all safety precautions and programs in connection with the performance of the Contract.

§ 10.1.1 The Contractor shall administer and comply with all the rules, standards, and regulations of the Construction Safety Act (40 U.S.C. 333) and the Williams-Stieger Occupational Safety and Health Act (OSHA) of 1970 (29 U.S.C. 650 et seq.) as administered and enforced by the Occupational Safety and Health Administration, Department of Labor. The Contractor shall further administer and comply with all the provisions, standards, rules and regulations of the Indiana Occupational Health and Safety Act (OSHA) of 1971 (I.C. § 22-8-1.1-1, et seq) including, but not limited to, 29 C.F.R. 1926, Subpart P (trench safety systems).

The Contractor shall not require or permit any laborer or mechanic, including apprentices and trainees, employed in the performance of this Contract to work in surroundings or under conditions which are unsanitary, hazardous or dangerous to health as determined under construction safety and health standards promulgated by the Secretary of Labor by regulation (29 CFR Part 1926, 36 FR 7340, April 17, 1971) pursuant to Section 107 of the Contract Work Hours and Safety Standards Act.

Init.

COMPLIANCE AFFIDAVIT

Each application for payment shall be accompanied by an affidavit, dated and signed by the Contractor, substantially as follows:

This is to certify that in the performance of this Contract, neither the undersigned Contractor nor (so far as the undersigned has knowledge) any of its Subcontractors, has violated the "Occupational Safety and Health Act" provisions of the General Conditions of the Contract.

§ 10.1.2 Contractor shall establish a program to coordinate the exchange of material safety data sheets or other hazard communication required to be made available to or exchanged between or among employers at the site in accordance with applicable laws or regulations. At all times during performance of the work, Contractor shall be responsible for administering the hazard communication program and coordinating the hazard communication. Contractor shall provide Superintendent with copies of all material safety data sheets or other hazard communication exchanged among or made available to employers at the site.

COMPLIANCE AFFIDAVIT

Each application for payment shall be accompanied by an affidavit, dated and signed by the Contractor, substantially as follows:

This is to certify that in the performance of this Contract, neither the undersigned Contractor, nor (so far as the undersigned has knowledge) any of its Subcontractors, has violated the "Hazard Communication" provision of the General Conditions of the Contract.

§ 10.2 Safety of Persons and Property

§ 10.2.1 The Contractor shall take reasonable precautions for safety of, and shall provide reasonable protection to prevent damage, injury, or loss to

- .1 employees on the Work and other persons who may be affected thereby;
- .2 the Work and materials and equipment to be incorporated therein, whether in storage on or off the site, under care, custody, or control of the Contractor, a Subcontractor, or a Sub-subcontractor; and
- .3 other property at the site or adjacent thereto, such as trees, shrubs, lawns, walks, pavements, roadways, structures, and utilities not designated for removal, relocation, or replacement in the course of construction.

§ 10.2.2 The Contractor shall comply with, and give notices required by applicable laws, statutes, ordinances, codes, rules and regulations, and lawful orders of public authorities, bearing on safety of persons or property or their protection from damage, injury, or loss.

§ 10.2.3 The Contractor shall implement, erect, and maintain, as required by existing conditions and performance of the Contract, reasonable safeguards for safety and protection, including posting danger signs and other warnings against hazards; promulgating safety regulations; and notifying the owners and users of adjacent sites and utilities of the safeguards.

§ 10.2.4 When use or storage of explosives or other hazardous materials or equipment, or unusual methods are necessary for execution of the Work, the Contractor shall exercise utmost care and carry on such activities under supervision of properly qualified personnel.

§ 10.2.5 The Contractor shall promptly remedy damage and loss (other than damage or loss insured under property insurance required by the Contract Documents) to property referred to in Sections 10.2.1.2 and 10.2.1.3 caused in whole or in part by the Contractor, a Subcontractor, a Sub-subcontractor, or anyone directly or indirectly employed by any of them, or by anyone for whose acts they may be liable and for which the Contractor is responsible under Sections 10.2.1.2 and 10.2.1.3, except damage or loss attributable to acts or omissions of the Owner or Architect or anyone directly or indirectly employed by either of them, or by anyone for whose acts either of them may be liable, and not attributable to the fault or negligence of the Contractor. The foregoing obligations of the Contractor are in addition to the Contractor's obligations under Section 3.1.8.

Init.

§ 10.2.6 The Contractor shall designate a responsible member of the Contractor's organization at the site whose duty shall be the prevention of accidents. This person shall be the Contractor's superintendent unless otherwise designated by the Contractor in writing to the Owner and Architect.

§ 10.2.7 The Contractor shall not permit any part of the construction or site to be loaded so as to cause damage or create an unsafe condition.

§ 10.2.8 Injury or Damage to Person or Property

If either party suffers injury or damage to person or property because of an act or omission of the other party, or of others for whose acts such party is legally responsible, notice of the injury or damage, whether or not insured, shall be given to the other party within a reasonable time not exceeding 48 hours after discovery. The notice shall provide sufficient detail to enable the other party to investigate the matter.

§ 10.3 Hazardous Materials and Substances

§ 10.3.1 The Contractor is responsible for compliance with any requirements included in the Contract Documents regarding hazardous materials.

§ 10.3.2 Owner shall be responsible for any hazardous materials, including asbestos, polychlorinated biphenyl ("PCBs"), petroleum (for example, oil, petroleum, fuel oil, oil sludge, oil refuse, gasoline, kerosene and oil mixed with other non-hazardous materials), Hazardous Waste (as defined in Section 1004 of the Solid Waste Disposal Act [42 U.S.C. Section 6903] as amended from time to time) or Radioactive Material (including source, special nuclear, or byproduct material as defined by the Atomic Energy Act of 1954 [52 U.S.C. Section 2011 et seq.] as amended from time to time) which are uncovered or revealed at the site and which were not shown or indicated in Drawings or Specifications or identified in the Contract Documents to be within the scope of the Work and which may present a substantial danger to persons or property exposed thereto in connection with the work at the site.

§ 10.3.3 To the extent that Hazardous Materials are shown or indicated in Drawings or Specifications or identified in the Contract Documents, but are not made the subject of supplementary conditions, then Contractor shall be responsible for the Hazardous Materials so shown, identified or indicated. In no event shall Owner be responsible for any Hazardous Materials brought to the site by Contractor, Subcontractors, Suppliers or anyone else for whom Contractor is responsible.

§ 10.3.4 To the extent that Contractor discovers Hazardous Materials (as described above) or that Contractor discovers materials which it either believes, or has reason to believe, may constitute Hazardous Materials, and which were not shown or indicated in the Drawings or Specifications or not identified in the Contract Documents then the Contractor shall:

- .1 immediately report the same to the Owner by the most expedient means available and confirm the report in writing; and
- .2 immediately cease all work in the vicinity of the materials believed to be hazardous.

The Owner shall then take measures, reasonable and appropriate under the circumstances, to ascertain the true character of the materials believed to be hazardous and the measures, if any, necessary to make the job site reasonably safe for the Contractor's completion of the work. Upon receiving notice from the Owner (which shall be confirmed in writing) to complete performance of the Work, Contractor shall immediately resume performance of the Work.

§ 10.3.5 The Owner shall not be responsible under this Section 10.3 for materials or substances the Contractor brings to the site unless such materials or substances are required by the Contract Documents. The Owner shall be responsible for materials or substances required by the Contract Documents, except to the extent of the Contractor's fault or negligence in the use and handling of such materials or substances.

§ 10.3.6 The Contractor shall indemnify the Owner for the cost and expense the Owner incurs (1) for remediation of a material or substance the Contractor brings to the site and negligently handles, or (2) where the Contractor fails to perform its obligations under Section 10.3.1, except to the extent that the cost and expense are due to the Owner's sole fault or negligence.

§ 10.4 Emergencies

In an emergency affecting safety of persons or property, the Contractor shall act, at the Contractor's discretion, to prevent threatened damage, injury, or loss. Additional compensation or extension of time claimed by the Contractor on account of an emergency shall be determined as provided in Article 15 and Article 7.

ARTICLE 11 INSURANCE AND BONDS

§ 11.1 Contractor's Insurance and Bonds

§ 11.1.1 Contractor shall purchase and maintain insurance of the types and limits of liability, containing the endorsements, and subject to the terms and conditions, as described in the Agreement or elsewhere in the Contract Documents. The Contractor shall purchase and maintain the required insurance from an insurance company or insurance companies lawfully authorized to issue insurance in the jurisdiction where the Project is located. The Owner, Architect, and Architect's consultants shall be named as additional insureds under the Contractor's commercial general liability policy or as otherwise described in the Contract Documents.

§ 11.1.2 The Contractor shall provide surety bonds of the types, for such penal sums, and subject to such terms and conditions as required by the Contract Documents. The Contractor shall purchase and maintain the required bonds from a company or companies lawfully authorized to issue surety bonds in the jurisdiction where the Project is located.

§ 11.1.3 Upon the request of any person or entity appearing to be a potential beneficiary of bonds covering payment of obligations arising under the Contract, the Contractor shall promptly furnish a copy of the bonds or shall authorize a copy to be furnished.

§ 11.1.4 **Notice of Cancellation or Expiration of Contractor's Required Insurance.** Within three (3) business days of the date the Contractor becomes aware of an impending or actual cancellation or expiration of any insurance required by the Contract Documents, the Contractor shall provide notice to the Owner of such impending or actual cancellation or expiration. Upon receipt of notice from the Contractor, the Owner shall, unless the lapse in coverage arises from an act or omission of the Owner, have the right to stop the Work until the lapse in coverage has been cured by the procurement of replacement coverage by the Contractor. The furnishing of notice by the Contractor shall not relieve the Contractor of any contractual obligation to provide any required coverage.

§ 11.2 Owner's Insurance

§ 11.2.1 The Owner shall be responsible for purchasing and maintaining the Owner's usual liability insurance.

§ 11.2.2 **Failure to Purchase Required Property Insurance.** If the Owner fails to purchase and maintain the required property insurance, with all of the coverages and in the amounts described in the Agreement or elsewhere in the Contract Documents, the Owner shall inform the Contractor in writing prior to commencement of the Work. Upon receipt of notice from the owner, the Contractor may obtain insurance that will protect the interests of the Contractor, Subcontractors, and Sub Subcontractors in the Work. The cost of the insurance shall be charged to the Owner by a Change Order. If the Owner does not provide written notice, and the Contractor is damaged by the failure or neglect of the Owner to purchase or maintain the required insurance, the Owner shall reimburse the Contractor for all reasonable costs and damages attributable thereto.

§ 11.2.3 Deleted

§ 11.3 Waivers of Subrogation

§ 11.3.1 The Owner and Contractor waive all rights against (1) each other and any of their subcontractors, sub-subcontractors, agents, and employees, each of the other; (2) the Architect and Architect's consultants; and (3) Separate Contractors, if any, and any of their subcontractors, sub-subcontractors, agents, and employees, for damages caused by fire, or other causes of loss, to the extent those losses are covered by property insurance required by the Agreement or other property insurance applicable to the Project, except such rights as they have to proceeds of such insurance. The Owner or Contractor, as appropriate, shall require similar written waivers in favor of the individuals and entities identified above from the Architect, Architect's consultants, Separate Contractors, subcontractors, and sub-subcontractors. The policies of insurance purchased and maintained by each person or entity agreeing to waive claims pursuant to this section 11.3.1 shall not prohibit this waiver of subrogation. This waiver of subrogation shall be effective as to a person or entity (1) even though that person or entity would otherwise have a duty of indemnification,

contractual or otherwise, (2) even though that person or entity did not pay the insurance premium directly or indirectly, or (3) whether or not the person or entity had an insurable interest in the damaged property.

§ 11.3.2 Deleted

(Paragraphs deleted)

§ 11.4 Deleted

§11.5 Adjustment and Settlement of Insured Loss

§ 11.5.1 A loss insured under the property insurance required by this Agreement shall be adjusted by the Owner.

§ 11.5.2 Prior to settlement of an insured loss, the Owner shall notify the Contractor of the terms of the proposed settlement as well as the proposed allocation of the insurance proceeds. The Contractor shall have 5 days from receipt of notice to object to the proposed settlement or allocation of the proceeds. If the Contractor does not object, the Owner shall settle the loss and the Contractor shall be bound by the settlement and allocation. If the Contractor timely objects to either the terms of the proposed settlement or the allocation of the proceeds, the Owner may proceed to settle the insured loss, and any dispute between the Owner and Contractor arising out of the settlement or allocation of the proceeds shall be resolved pursuant to Article 15. Pending resolution of any dispute, the Owner may issue a Construction Change Directive for the reconstruction of the damaged or destroyed Work.

§11.6 Refer to AIA Document A101™ - 2017 Exhibit A, as modified, for insurance requirements.

ARTICLE 12 UNCOVERING AND CORRECTION OF WORK

§ 12.1 Uncovering of Work

§ 12.1.1 If a portion of the Work is covered contrary to the Architect's request or to requirements specifically expressed in the Contract Documents, it must, if requested in writing by the Architect, be uncovered for the Architect's examination and be replaced at the Contractor's expense without change in the Contract Time.

§ 12.1.2 If a portion of the Work has been covered that the Architect has not specifically requested to examine prior to its being covered, the Architect may request to see such Work and it shall be uncovered by the Contractor. If such Work is in accordance with the Contract Documents, the Contractor shall be entitled to an equitable adjustment to the Contract Sum and Contract Time as may be appropriate. If such Work is not in accordance with the Contract Documents, the costs of uncovering the Work, and the cost of correction, shall be at the Contractor's expense.

§ 12.2 Correction of Work

§ 12.2.1 Before Substantial Completion

The Contractor shall promptly correct Work rejected by the Architect or failing to conform to the requirements of the Contract Documents, discovered before Substantial Completion and whether or not fabricated, installed or completed. Costs of correcting such rejected Work, including additional testing and inspections, the cost of uncovering and replacement, and compensation for the Architect's services and expenses made necessary thereby, shall be at the Contractor's expense.

§ 12.2.2 After Substantial Completion

§ 12.2.2.1 In addition to the Contractor's obligations under Section 3.5, if, within one year after the date of Substantial Completion of the Work or designated portion thereof or after the date for commencement of warranties established under Section 9.9.1, or by terms of any applicable special warranty required by the Contract Documents, any of the Work is found to be not in accordance with the requirements of the Contract Documents, the Contractor shall correct it promptly after receipt of notice from the Owner to do so, unless the Owner has previously given the Contractor a written acceptance of such condition. The Owner shall give such notice promptly after discovery of the condition. If the Contractor fails to correct nonconforming Work within a reasonable time during that period after receipt of notice from the Owner or Architect, the Owner may correct it in accordance with Section 2.5.

§ 12.2.2.2 The one-year period for correction of Work shall be extended with respect to portions of Work first performed after Substantial Completion by the period of time between Substantial Completion and the actual completion of that portion of the Work.

§ 12.2.2.3 The one-year period for correction of Work shall not be extended by corrective Work performed by the Contractor pursuant to this Section 12.2.

§ 12.2.3 The Contractor shall remove from the site portions of the Work that are not in accordance with the requirements of the Contract Documents and are neither corrected by the Contractor nor accepted by the Owner.

§ 12.2.4 The Contractor shall bear the cost of correcting destroyed or damaged construction of the Owner or Separate Contractors, whether completed or partially completed, caused by the Contractor's correction or removal of Work that is not in accordance with the requirements of the Contract Documents.

§ 12.2.5 Nothing contained in this Section 12.2 shall be construed to establish a period of limitation with respect to other obligations the Contractor has under the Contract Documents. Establishment of the one-year period for correction of Work as described in Section 12.2.2 relates only to the specific obligation of the Contractor to correct the Work, and has no relationship to the time within which the obligation to comply with the Contract Documents may be sought to be enforced, nor to the time within which proceedings may be commenced to establish the Contractor's liability with respect to the Contractor's obligations other than specifically to correct the Work.

§ 12.3 Acceptance of Nonconforming Work

If the Owner prefers to accept Work that is not in accordance with the requirements of the Contract Documents, the Owner may do so instead of requiring its removal and correction, in which case the Contract Sum will be reduced as appropriate and equitable. Such adjustment shall be effected whether or not final payment has been made.

ARTICLE 13 MISCELLANEOUS PROVISIONS

§ 13.1 Governing Law

The Contract shall be governed by the law of the State of Indiana. Any action by Contractor or Owner to enforce rights or obligations, or to assert Claims arising out of this Agreement (including cross-claims and third-party claims) shall be brought and maintained only in a court of competent jurisdiction in Tippecanoe County, Indiana.

§ 13.2 Successors and Assigns

§ 13.2.1 The Owner and Contractor respectively bind themselves, their partners, successors, assigns, and legal representatives to covenants, agreements, and obligations contained in the Contract Documents. Except as provided in Section 13.2.2, neither party to the Contract shall assign the Contract as a whole without written consent of the other. If either party attempts to make an assignment without such consent, that party shall nevertheless remain legally responsible for all obligations under the Contract. Contractor shall not assign, or permit the assignment of, any Claim arising out of this Agreement.

§ 13.2.2 The Owner may, without consent of the Contractor, assign the Contract to a lender providing construction financing for the Project, if the lender assumes the Owner's rights and obligations under the Contract Documents. The Contractor shall execute all consents reasonably required to facilitate the assignment.

§ 13.3 Rights and Remedies

§ 13.3.1 Duties and obligations imposed by the Contract Documents and rights and remedies available thereunder shall be in addition to and not a limitation of duties, obligations, rights, and remedies otherwise imposed or available by law.

§ 13.3.2 No action or failure to act by the Owner, Architect, or Contractor shall constitute a waiver of a right or duty afforded them under the Contract, nor shall such action or failure to act constitute approval of or acquiescence in a breach thereunder, except as may be specifically agreed upon in writing.

§ 13.4 Tests and Inspections

§ 13.4.1 Tests, inspections, and approvals of portions of the Work shall be made as required by the Contract Documents and by applicable laws, statutes, ordinances, codes, rules, and regulations or lawful orders of public authorities. Unless otherwise provided, the Contractor shall make arrangements for such tests, inspections, and approvals with an independent testing laboratory or entity retained by the Owner. The Contractor shall give the Architect and the Owner timely notice of when and where tests and inspections are to be made so that the Architect and Owner may be present for such procedures.

§ 13.4.2 If the Architect, Owner, or public authorities having jurisdiction determine that portions of the Work require additional testing, inspection, or approval not included under Section 13.4.1, the Architect will, upon written authorization from the Owner, instruct the Contractor to make arrangements for such additional testing, inspection, or approval, by an entity retained by the Owner, and the Contractor shall give timely notice to the Architect and Owner of when and where tests and inspections are to be made so that the Architect and Owner may be present for such procedures. Such costs, except as provided in Section 13.4.3, shall be at the Owner's expense.

§ 13.4.3 If procedures for testing, inspection, or approval under Sections 13.4.1 and 13.4.2 reveal failure of the portions of the Work to comply with requirements established by the Contract Documents, all costs made necessary by such failure, including those of repeated procedures and compensation for the Architect's services and expenses, shall be at the Contractor's expense.

§ 13.4.4 Required certificates of testing, inspection, or approval shall, unless otherwise required by the Contract Documents, be secured by the Contractor and promptly delivered to the Architect and Contractor.

§ 13.4.5 If the Architect is to observe tests, inspections, or approvals required by the Contract Documents, the Architect will do so promptly and, where practicable, at the normal place of testing.

§ 13.4.6 Tests or inspections conducted pursuant to the Contract Documents shall be made promptly to avoid unreasonable delay in the Work.

§ 13.5 Interest

Payments due and unpaid under the Contract Documents shall bear interest from the date payment is due at the rate the parties agree upon in writing or, in the absence thereof, at the legal rate prevailing from time to time at the place where the Project is located.

§ 13.6 Drug Testing Program

The laws of the State of Indiana (IC 4-13-18 as amended) contain certain special provisions regarding drug testing of employees of public works Contractors and Subcontractors. As determined by the Owner, projects estimated to be in excess of \$150,000.00 will be governed by these provisions. These provisions require, among other things, that the Contractor submit with the bid a written plan for a program to test the Contractor's employees for drugs. In addition, each successful Bidder will be required to comply with all applicable provisions of the statute referred to above with respect to each Bidder's Subcontractors, as the term "Subcontractor" is defined in the statute referred to above.

COMPLIANCE AFFIDAVIT

Each application for payment shall be accompanied by an affidavit, dated and signed by the Contractor, substantially as follows:

This is to certify that in the performance of this Contract, neither the undersigned Contractor, nor (so far as the undersigned has knowledge) any of its Subcontractors, has violated the "Drug Testing Program" provision of the General Conditions of the Contract.

§ 13.7 Background Checks and Security Clearance

Contractor shall perform security clearance background checks on all of its officers, agents, employees assigned to have access to Purdue's facilities to identify whether any such individual is a registered sex offender pursuant to Zachary's Law, Ind. Code § 11-8-8 et. seq. or the equivalent law of the individual's state of residence. Contractor shall either perform such checks on the officers, agents or employees of subcontractors of any tier or shall require that such subcontractors certify to the Contractor and the Owner that such checks have been performed. Neither Contractor nor any subcontractor (of any tier) shall assign an individual identified as a registered sex offender to perform work or services at Purdue's facilities. Purdue reserves the right to immediately remove any individuals identified as registered sex offenders from Purdue's facilities. Purdue reserves the right to require additional background checks be made on any of Contractor's and its subcontractor(s)'s officers, agents, employees or volunteers assigned to have access to Purdue's premises. Contractor shall indemnify Purdue and hold it harmless from and against all liability, losses,

damages, claims, liens, and expense (including reasonable legal fees) arising out of or connected with Contractor's failure to comply with the requirements of this Article of the General Conditions.

COMPLIANCE AFFIDAVIT

Each application for payment shall be accompanied by an affidavit, dated and signed by the Contractor, substantially as follows:

This is to certify that in the performance of this Contract, neither the undersigned Contractor, nor (so far as the undersigned has knowledge) any of its Subcontractors, has violated the "Background Checks and Security Clearance" provision of the General Conditions of the Contract.

§ 13.8 Subcontractor Spend Data

Contractor shall monitor its payments to its subcontractors and material suppliers and report, on a monthly basis, its disbursement of each Project payment received from the Owner.

COMPLIANCE AFFIDAVIT

Each pay application for payment shall be accompanied by an affidavit dated and signed by the Contractor, substantially as follows:

This is to certify that the Contractor has received the Owner's payment of its prior application for payment, subject to any disputed items, and has disbursed payment to its subcontractors and material suppliers as set forth below:

Subcontractor	Amount	Date
_____	_____	_____

§ 13.9 Nondiscrimination

§ 13.9.1 The Contractor shall perform, observe and comply with all applicable State, Municipal and Federal laws, rules, regulations and Executive Orders pertaining to nondiscrimination against employees or applicants for employment because of race, color, religion, sex, handicap, disability, national origin or ancestry. During the performance of this Contract, the Contractor agrees to comply with all applicable requirements of the Americans with Disabilities Act of 1990 and the regulations promulgated thereunder. When required by such laws, rules, regulations and Executive Orders, the Contractor shall include nondiscrimination provisions in all contracts and purchase orders.

§ 13.9.2 The Contractor agrees that:

- .1 In the hiring of employees for the performance of work under this Contract or any subcontract hereunder, neither the Contractor, any Subcontractor, nor any person acting on behalf of the Contractor or Subcontractor, shall, by reason of race, religion, color, sex, national origin or ancestry or handicap, discriminate against any citizen of the State of Indiana who is qualified and available to perform the work to which the employment relates;
- .2 Neither the Contractor, Subcontractor, nor any person on their behalf shall, in any manner, discriminate against or intimidate any employee hired for the performance of work under this Contract on account of race, religion, color, sex, national origin or ancestry, or handicap;
- .3 There may be deducted from the amount payable to the Contractor by the Owner, under this Contract, a penalty of five dollars (\$5.00) for each person for each calendar day during which such person was discriminated against or intimidated in violation of these nondiscrimination provisions; and
- .4 This Contract may be canceled or terminated by the Owner, and all money due or to become due hereunder may be forfeited, for a second or any subsequent violation of the terms or conditions of these nondiscrimination provisions.

§ 13.9.3 By the act of submitting a Bid, each Bidder shall be deemed to have certified to the Owner that it has at all times complied with the nondiscrimination provisions of Senate Enrolled Act No. 484 - Section 4 enacted by the First

Init.

Regular Session 99th General Assembly 1975, unless such Bidder states otherwise in a written statement submitted with the Bid. The Owner will refrain from entering into any contract with any Bidder who states that it has failed to comply with said nondiscrimination provisions of said Senate Enrolled Act. No. 484 - Section 4. The applicable portion of Senate Enrolled Act No. 484 - Section 4 is as follows:

"SECTION 4. IC1971, 22 0-10, as amended by Acts 1971, P.L. 347, SECTION 7, is amended to read as follows: Sec. 10. Every contract to which the state or any of its political or civil subdivisions is a party, including franchises granted to public utilities, shall contain a provision requiring the Contractor and his Subcontractors not to discriminate against any employee or applicant for employment, to be employed in the performance of such contract, with respect to his hire, tenure, terms, conditions or privileges of employment or any matter directly or indirectly related to employment, because of his race, religion, color, sex, handicap, national origin or ancestry. Breach of this covenant may be regarded as a material breach of the contract.

Each application for payment shall be accompanied by a nondiscrimination certificate.

COMPLIANCE AFFIDAVIT

Each application for payment shall be accompanied by a certificate, dated and signed by the Contractor, substantially as follows:

"This is to certify that in the performance of this Contract, neither the undersigned Contractor nor (so far as the undersigned has knowledge) any of its Subcontractors has violated the provisions of 'Nondiscrimination Provisions' of these General Conditions".

§ 13.10 American Steel

To the extent that the Contractor's performance of the Work entails the use of purchase of steel products (as defined in I.C. 5-16-8-1, as amended from time to time), then Contractor warrants that only steel products made in the United States shall be used and supplied in the performance of the Contract and in the performance of any subcontracts.

§ 13.11 Open Competition

Where in the Specifications one or more certain materials, trade names, or articles of certain manufacture are mentioned, it is done for the express purpose of establishing a basis of durability and efficiency and not for the purpose of limiting competition. Other names or materials can be used, if in the opinion of the Architect they are equal in durability and efficiency to those mentioned and of a design in harmony within the work as outlined and the Architect gives written approval of a substitution before the articles and material are ordered by the Contractor.

§ 13.12 Parking Regulations

The contractor and its employees are to conform to the University's Motor Vehicle and Traffic Regulations. See Division 1 of the Specifications.

§ 13.13 Contribution by Tier 1 Contractor

The laws of the State of Indiana (IC 5-16-13-9 as amended) contain certain special provisions regarding contribution by the Tier 1 Contractor on public works projects. The Tier 1 Contractor must contribute in work, material, services, or any combination thereof, at least fifteen percent (15%) of the awarded contract price.

COMPLIANCE AFFIDAVIT

Each application for payment shall be accompanied by an affidavit, dated and signed by the Contractor, substantially as follows:

This is to certify that in the performance of this Contract the undersigned Contractor has not violated the "Contribution by Tier 1 Contractor" provision of the General Conditions of the Contract.

§ 13.14 E-Verify Program

The laws of the State of Indiana (I.C. 22-5-1.7-11.1 as amended) contain certain special provisions regarding

enrollment and participation in the E-Verify program by public works Contractors and Subcontractors. These provisions require, among other things, that the Contractor signs an affidavit affirming that the contractor does not knowingly employ an unauthorized alien. In addition, each successful Bidder will be required to comply with all applicable provisions of the statute referred to above with respect to each Bidder's Subcontractors, as the term "Subcontractor" is defined in the statute referred to above. A Contractor is not required to verify the work eligibility status of all newly hired employees of the contractor through the E-verify program if E-verify no longer exists.

COMPLIANCE AFFIDAVIT

Each application for payment shall be accompanied by an affidavit, dated and signed by the Contractor, substantially as follows:

This is to certify that in the performance of this Contract, neither the undersigned Contractor, nor (so far as the undersigned has knowledge) any of its Subcontractors, has violated the "E-Verify Program" provision of the General Conditions of the Contract.

§ 13.15 Contractor Pre-Qualifications

The laws of the State of Indiana (I.C. 5-16-13-10(c) as amended) contain certain special provisions regarding pre-qualification of contractors on public works projects. Contractors must be pre-qualified under I.C. 4-13.6-4 or I.C. 8-23-10.

COMPLIANCE AFFIDAVIT

Each application for payment shall be accompanied by an affidavit, dated and signed by the Contractor, substantially as follows:

This is to certify that in the performance of this Contract the undersigned Contractor and its Subcontractors are in compliance with the "Contractor Pre-Qualifications" requirements set forth in I.C. 5-16-13-10(c).

ARTICLE 14 TERMINATION OR SUSPENSION OF THE CONTRACT

§ 14.1 Termination by the Contractor

§ 14.1.1 The Contractor may terminate the Contract if the Work is stopped for a period of 30 consecutive days through no act or fault of the Contractor, a Subcontractor, a Sub-subcontractor, their agents or employees, or any other persons or entities performing portions of the Work, for any of the following reasons:

- .1 Issuance of an order of a court or other public authority having jurisdiction that requires all Work to be stopped;
- .2 An act of government, such as a declaration of national emergency, that requires all Work to be stopped;
- .3 Because the Architect has not issued a Certificate for Payment and has not notified the Contractor of the reason for withholding certification as provided in Section 9.4.1, or because the Owner has not made payment on a Certificate for Payment within the time stated in the Contract Documents; or

(Paragraph deleted)

§ 14.1.2 The Contractor may terminate the Contract if, through no act or fault of the Contractor, a Subcontractor, a Sub-subcontractor, their agents or employees, or any other persons or entities performing portions of the Work, repeated suspensions, delays, or interruptions of the entire Work by the Owner as described in Section 14.3, constitute in the aggregate more than 100 percent of the total number of days scheduled for completion, or 120 days in any 365-day period, whichever is less.

§ 14.1.3 If one of the reasons described in Section 14.1.1 or 14.1.2 exists, the Contractor may, upon seven days' notice to the Owner and Architect, terminate the Contract and recover from the Owner payment for Work executed, as well as reasonable overhead and profit on Work not executed, and costs incurred by reason of such termination.

§ 14.1.4 If the Work is stopped for a period of 60 consecutive days through no act or fault of the Contractor, a Subcontractor, a Sub-subcontractor, or their agents or employees or any other persons or entities performing portions of the Work because the Owner has repeatedly failed to fulfill the Owner's obligations under the Contract Documents

Init.

with respect to matters important to the progress of the Work, the Contractor may, upon seven additional days' notice to the Owner and the Architect, terminate the Contract and recover from the Owner as provided in Section 14.1.3.

§ 14.2 Termination by the Owner for Cause

§ 14.2.1 The Owner may terminate the Contract if the Contractor

- .1 repeatedly refuses or fails to supply enough properly skilled workers or proper materials;
- .2 fails to make payment to Subcontractors or suppliers in accordance with the respective agreements between the Contractor and the Subcontractors or suppliers;
- .3 repeatedly disregards applicable laws, statutes, ordinances, codes, rules and regulations, or lawful orders of a public authority; or
- .4 otherwise is guilty of substantial breach of a provision of the Contract Documents.

§ 14.2.2 When any of the above reasons described in Section 14.2.1 exist, the Owner may, without prejudice to any other rights or remedies of the Owner and after giving the Contractor and the Contractor's surety, if any, seven days' notice, terminate employment of the Contractor and may, subject to any prior rights of the surety:

- .1 Exclude the Contractor from the site and take possession of all materials, equipment, tools, and construction equipment and machinery thereon owned by the Contractor;
- .2 Accept assignment of subcontracts pursuant to Section 5.4; and
- .3 Finish the Work by whatever reasonable method the Owner may deem expedient. Upon written request of the Contractor, the Owner shall furnish to the Contractor a detailed accounting of the costs incurred by the Owner in finishing the Work.

§ 14.2.3 When the Owner terminates the Contract for one of the reasons stated in Section 14.2.1, the Contractor shall not be entitled to receive further payment until the Work is finished.

§ 14.2.4 If the unpaid balance of the Contract Sum exceeds costs of finishing the Work, including compensation for the Architect's services and expenses made necessary thereby, and other damages incurred by the Owner and not expressly waived, such excess shall be paid to the Contractor. If such costs and damages exceed the unpaid balance, the Contractor shall pay the difference to the Owner. The amount to be paid to the Contractor or Owner, as the case may be, shall be certified by the Initial Decision Maker, upon application, and this obligation for payment shall survive termination of the Contract.

§ 14.3 Suspension by the Owner for Convenience

§ 14.3.1 The Owner may, without cause, order the Contractor in writing to suspend, delay or interrupt the Work, in whole or in part for such period of time as the Owner may determine.

§ 14.3.2 The Contract Sum and Contract Time shall be adjusted for increases in the cost and time caused by suspension, delay, or interruption under Section 14.3.1. Adjustment of the Contract Sum shall include profit. No adjustment shall be made to the extent

- .1 that performance is, was, or would have been, so suspended, delayed, or interrupted, by another cause for which the Contractor is responsible; or
- .2 that an equitable adjustment is made or denied under another provision of the Contract.

§ 14.4 Termination by the Owner for Convenience

§ 14.4.1 The Owner may, at any time, terminate the Contract for the Owner's convenience and without cause.

§ 14.4.2 Upon receipt of notice from the Owner of such termination for the Owner's convenience, the Contractor shall

- .1 cease operations as directed by the Owner in the notice;
- .2 take actions necessary, or that the Owner may direct, for the protection and preservation of the Work; and
- .3 except for Work directed to be performed prior to the effective date of termination stated in the notice, terminate all existing subcontracts and purchase orders and enter into no further subcontracts and purchase orders.

§ 14.4.3 In case of such termination for the Owner's convenience, the Contractor shall be entitled to receive payment for Work properly executed and costs actually and reasonably incurred by reason of such termination.

§ 14.4.4 When the Owner terminates the Contractor's services pursuant to this Section, the termination shall not affect the rights or remedies of the Owner against the Contractor then existing or which may thereafter accrue.

ARTICLE 15 CLAIMS AND DISPUTES

§ 15.1 Claims

§ 15.1.1 Definition

A Claim is a demand or assertion by one of the parties seeking, as a matter of right, payment of money, a change in the Contract Time, or other relief with respect to the terms of the Contract. The term "Claim" also includes other disputes and matters in question between the Owner and Contractor arising out of or relating to the Contract. The responsibility to substantiate Claims shall rest with the party making the Claim. This Section 15.1.1 does not require the Owner to file a Claim in order to impose liquidated damages in accordance with the Contract Documents.

§ 15.1.2 Time Limits on Claims

Any litigation filed by the Contractor or its Subcontractors asserting any right, claim or cause of action against the Owner arising out of or related in any way to the Contract or Contractor's performance of the Work must be commenced within one year of Substantial Completion. The Owner shall be entitled to the immediate dismissal of any such litigation brought more than one year after Substantial Completion. Any such right, claim or cause of action asserted by the Contractor or its Subcontractors against the Owner more than one year after Substantial Completion is waived by the Contractor.

§ 15.1.3 Notice of Claims

§ 15.1.3.1 Claims by either the Owner or Contractor where the condition giving rise to the Claim is first discovered prior to the expiration of the period for correction of the Work set forth in Section 12.2.2, shall be initiated by Notice to the other party and to the Initial Decision Maker with a copy sent to the Architect, if the Architect is not serving as the Initial Decision Maker. Claims by either party must be initiated within the specific time period required by the Contract Documents and in the absence of a specific time period then no later than 21 days after occurrence of the event giving rise to such Claim or within 21 days after the claimant first recognizes the condition giving rise to the Claim, whichever is later. The timely giving of Notice shall be a condition precedent to any entitlement to adjustment in the Contract Time or the Contract Sum. The failure to provide timely Notice of a Claim constitutes an irremovable waiver of such Claim.

§ 15.1.3.2 Claims by either the Owner or Contractor, where the condition giving rise to the Claim is first discovered after expiration of the period for correction of the Work set forth in Section 12.2.2, shall be initiated by notice to the other party. In such event, no decision by the Initial Decision Maker is required.

§ 15.1.4 Continuing Contract Performance

§ 15.1.4.1 Pending final resolution of a Claim, except as otherwise agreed in writing or as provided in Section 9.7 and Article 14, the Contractor shall proceed diligently with performance of the Contract and the Owner shall continue to make payments in accordance with the Contract Documents.

§ 15.1.4.2 The Contract Sum and Contract Time shall be adjusted in accordance with the Initial Decision Maker's decision, subject to the right of either party to proceed in accordance with this Article 15. The Architect will issue Certificates for Payment in accordance with the decision of the Initial Decision Maker.

§ 15.1.5 Claims for Additional Cost

If the Contractor wishes to make a Claim for an increase in the Contract Sum, notice as provided in Section 15.1.3 shall be given before proceeding to execute the portion of the Work that is the subject of the Claim. Prior notice is not required for Claims relating to an emergency endangering life or property arising under Section 10.4.

§ 15.1.6 Claims for Additional Time

§ 15.1.6.1 If the Contractor wishes to make a Claim for an increase in the Contract Time, notice as provided in Section 15.1.3 shall be given. The Contractor's Claim shall include an estimate of cost and of probable effect of delay on progress of the Work. In the case of a continuing delay, only one Claim is necessary. In the case of a continuing delay occurring on consecutive days, only one Claim is necessary; provided, however, that within ten days after the cessation of the cause of the continuing delay, the Contractor shall notify the Owner and Architect in writing that the cause of the delay has ceased. The failure to give timely notice of the cessation of the cause of the continuing delay will constitute an irrevocable waiver of any Claim based on the continuing delay.

Init.

§ 15.1.6.2 If adverse weather conditions are the basis for a Claim for additional time, such Claim shall be documented by data substantiating that weather conditions were abnormal for the period of time, could not have been reasonably anticipated, and had an adverse effect on the scheduled construction. Notwithstanding any other provision of the Contract Documents to the contrary, the Contract Time will not be adjusted on account of the impact of any normal adverse weather on any of the Work or on account of the impact of any abnormal adverse weather on non-critical elements of the Work. The support for and evaluation of all adverse weather Claims shall be based upon average weather conditions during the 10 years immediately preceding the dates at issue in the Claim as such weather conditions were recorded at the government controlled weather-recording facility nearest to the project.

(Paragraphs deleted)

§ 15.1.7 Deleted

§ 15.2 Initial Decision

§ 15.2.1 Claims, excluding those where the condition giving rise to the Claim is first discovered after expiration of the period for correction of the Work set forth in Section 12.2.2 or arising under Sections 10.3, 10.4, and 11.5, shall be referred to the Initial Decision Maker for initial decision. The Architect will serve as the Initial Decision Maker, unless otherwise indicated in the Agreement. Except for those Claims excluded by this Section 15.2.1, an initial decision shall be required as a condition precedent to mediation of any Claim. If an initial decision has not been rendered within 30 days after the Claim has been referred to the Initial Decision Maker, the party asserting the Claim may demand mediation and binding dispute resolution without a decision having been rendered. Unless the Initial Decision Maker and all affected parties agree, the Initial Decision Maker will not decide disputes between the Contractor and persons or entities other than the Owner.

§ 15.2.2 The Initial Decision Maker will review Claims and within ten days of the receipt of a Claim take one or more of the following actions: (1) request additional supporting data from the claimant or a response with supporting data from the other party, (2) reject the Claim in whole or in part, (3) approve the Claim, (4) suggest a compromise, or (5) advise the parties that the Initial Decision Maker is unable to resolve the Claim if the Initial Decision Maker lacks sufficient information to evaluate the merits of the Claim or if the Initial Decision Maker concludes that, in the Initial Decision Maker's sole discretion, it would be inappropriate for the Initial Decision Maker to resolve the Claim.

§ 15.2.3 In evaluating Claims, the Initial Decision Maker may, but shall not be obligated to, consult with or seek information from either party or from persons with special knowledge or expertise who may assist the Initial Decision Maker in rendering a decision. The Initial Decision Maker may request the Owner to authorize retention of such persons at the Owner's expense.

§ 15.2.4 If the Initial Decision Maker requests a party to provide a response to a Claim or to furnish additional supporting data, such party shall respond, within ten days after receipt of the request, and shall either (1) provide a response on the requested supporting data, (2) advise the Initial Decision Maker when the response or supporting data will be furnished, or (3) advise the Initial Decision Maker that no supporting data will be furnished. Upon receipt of the response or supporting data, if any, the Initial Decision Maker will either reject or approve the Claim in whole or in part.

§ 15.2.5 The Initial Decision Maker will render an initial decision approving or rejecting the Claim, or indicating that the Initial Decision Maker is unable to resolve the Claim. This initial decision shall (1) be in writing; (2) state the reasons therefor; and (3) notify the parties and the Architect, if the Architect is not serving as the Initial Decision Maker, of any change in the Contract Sum or Contract Time or both. The initial decision shall be final and binding on the parties but subject to mediation and, if the parties fail to resolve their dispute through mediation, to binding dispute resolution.

§ 15.2.6 Either party may file for mediation of an initial decision at any time.

§ 15.2.6.1 Deleted

§ 15.2.7 In the event of a Claim against the Contractor, the Owner may, but is not obligated to, notify the surety, if any, of the nature and amount of the Claim. If the Claim relates to a possibility of a Contractor's default, the Owner may, but is not obligated to, notify the surety and request the surety's assistance in resolving the controversy.

Init.

§ 15.2.8 If a Claim relates to or is the subject of a mechanic's lien or verified claim, the party asserting such Claim may proceed in accordance with applicable law to comply with the lien notice or filing deadlines.

§ 15.3 Mediation

§ 15.3.1 Claims, disputes, or other matters in controversy arising out of or related to the Contract, except those waived as provided for in Sections 9.10.4, and 9.10.5, shall be subject to mediation as a condition precedent to binding dispute resolution.

§ 15.3.2 The parties shall endeavor to resolve their Claims by mediation. A request for mediation shall be made in writing, delivered to the other party to the Contract, and filed with the person or entity administering the mediation. The request may be made concurrently with the filing of binding dispute resolution proceedings but, in such event, mediation shall proceed in advance of binding dispute resolution proceedings, which shall be stayed pending mediation for a period of 60 days from the date of filing, unless stayed for a longer period by agreement of the parties or court order.

§ 15.3.3 Either party may, within 30 days from the date that mediation has been concluded without resolution of the dispute or 60 days after mediation has been demanded without resolution of the dispute, demand in writing that the other party file for binding dispute resolution. If such a demand is made and the party receiving the demand fails to file for binding dispute resolution within 60 days after receipt thereof, then both parties waive their rights to binding dispute resolution proceedings with respect to the initial decision.

§ 15.3.4 The parties shall share the mediator's fee and any filing fees equally. The mediation shall be held in the place where the Project is located, unless another location is mutually agreed upon. Agreements reached in mediation shall be enforceable as settlement agreements in any court having jurisdiction thereof.

§ 15.4 Deleted

(Paragraphs deleted)

AACC	Asian American and Asian Resource and Cultural Center F6	KRAN	Krannert Building H8	VLAB	Veterinary Laboratory Animal Building G10
AAPF	Ag Alumni Seed Phenotyping Facility F8	KRCH	Krach Leadership Center E6	VMIF	Veterinary Medicine Isolation Facility G10
ABE	Agricultural and Biological Engineering F9	LAMB	Lambert (Ward L.) Fieldhouse and Gymnasium G4	VOIN	Voinoff (Samuel) Golf Pavilion C1
ADDL	Animal Disease Diagnostic Laboratory G10	LCCP	Latino Cultural Center at Purdue F6	VPRB	Veterinary Pathobiology Research Building F9, 10
ADM	ADM Agricultural Innovation Center E11	LG	Lambert Green G4	VPTH	Veterinary Pathology Building G9
■	Admissions, Office of (Stewart Center 102) H7	■	Library, Main (see HIKS) H8	WADE	Wade (Walter W.) Utility Plant H11
ADPA-C	Aspire at Discovery Park D8	LILY	Lilly Hall of Life Sciences F8	WALC	Wilmeth (Thomas S. and Harvey D.) Active Learning Center G6
AERO	Aerospace Science Laboratory C11	LMBS	Lambertus Hall H6	WANG	Wang (Seng-Liang) Hall H5
AGAD	Agricultural Administration Building G8	LMSB	Laboratory Materials Storage Building H11	■	Welcome Center (see STEW) H7
AHF	Animal Holding Facility G10	LMST	Laboratory Materials Storage Trailer H11	WEST	Westwood (President's Home) A5, 6
AQUA	Burke (Morgan J.) Boilermaker Aquatic Center D6	LOLC	Land O'Lakes Center for Experiential Learning and Purina Pavilion F9	WGLR	Women's Golf Locker Room D1
AR	Armory F6	LSA	Life Science Animal Building F8	WSLR	Whistler (Roy L.) Hall of Agricultural Research G8
ARMS	Armstrong (Neil) Hall of Engineering G5	LSPS	Life Science Plant and Soils Laboratory F8	WTHR	Wetherill (Richard Benbridge) Laboratory of Chemistry G7
ASB	Airport Service Building (Shop Services) A11-12	LSR	Life Science Ranges (Greenhouse and Service Building) F8	YONG	Young (Ernest C.) Hall H8
BALY	Bailey (Ralph and Bettye) Hall H6-7	LWSN	Lawson (Richard and Patricia) Computer Science Building F6	† ZL1	Combustion Research Laboratory
BCC	Black Cultural Center F6	LYLE	Lyles-Porter Hall F9	† ZL2	Gas Dynamics Research Laboratory
BCHM	Biochemistry Building F8	LYNN	Lynn (Charles J.) Hall of Veterinary Medicine G10	† ZL3	High Pressure Research Laboratory
BHEE	Brown (Max W & Maileen) Family Hall H6	MACK	Mackey (Guy J.) Arena F, G4	† ZL4	Propulsion Research Laboratory
BIDC	Bechtel Innovation Design Center F6	MANN	Mann (Gerald D. and Edna E.) Hall D8	† ZL5	Turbomachinery Fluid Dynamics Laboratory
BIND	Bindley Bioscience Center D8	MATH	Mathematical Sciences Building G7	† ZL8	High Pressure Combustion Laboratory
BOWN	Bowen (Robert L. & Terry L.) Laboratory H12 (Inset)	ME	Mechanical Engineering Building H6		
BREQ	Brunner (David and Bonnie) Equine Hospital G10	MJIS	Jischke (Martin C.) Hall of Biomedical Engineering E9	Residence & Dining Facilities	
BRES	Brees (Drew and Brittany) Student-Athlete Academic Center F3	MMDC	Materials Management and Distribution Center F11	CARY	Cary (Franklin Levering) Quadrangle F4
BRFM	Brunner (David and Bonnie) Farm Animal Hospital H10	MMSI	Materials Management Storage Building 1 F12	* DUHM	Duhme (Ophelia) Residence Hall E7
BRUN	Brunner (David and Bonnie) Small Animal Hospital G10	MOLL	Mollenkopf Athletic Center F3	ERHT	Earhart (Amelia) Residence Hall D7
BRK	Birck Nanotechnology Center D8	MRGN	Morgan (Burton D.) Center for Entrepreneurship D8	FORD	Ford (Fred and Mary) Dining Court E4
BRNG	Beering (Steven C.) Hall of Liberal Arts and Education G7	MRRT	Marriott Hall F7,8	FST	First Street Towers D7
BRWN	Brown (Herbert C.) Laboratory of Chemistry H7	MSEE	Materials and Electrical Engineering Building H5	HARR	Harrison (Benjamin) Residence Hall C7
BTV	Boiler Television Building E3	MTHW	Matthews Hall F8	HAWK	Hawkins (George A.) Hall H8
■	Car/Van Rentals and Charter Bus (MMDC) F11	NACC	Native American Educational and Cultural Center F6	HCRN	Honors College and Residences North E7
† CHAF	Chaffee Hall A9	NISW	Niswonger Aviation Technology Building B11	HCRS	Honors College and Residences South E7
CHAS	Chaney-Hale Hall of Science G6	NLSN	Nelson (Philip E.) Hall of Food Science G9	HILL	Hillenbrand Residence Hall C7
CL50	Class of 1950 Lecture Hall G7	OLMN	Ollman (Melvin L.) Golfcart Barn C1	HLTP	Hilltop Apartments E3
COMP	Composites Laboratory C11	PAGE	Page (Thomas A.) Pavilion H12 (Inset)	MCUT	McCutcheon (John T.) Residence Hall C7
CONV	Convergence C8	■	Parking Facilities (MMDC) F11	MRDH	Meredith (Virginia C.) Residence Hall D7
CREC	Córdova (France A.) Recreational Sports Center E6	PAO	Pao (Yue-Kong) Hall of Visual and Performing Arts H8	MRDS	Meredith (Virginia C.) Residence Hall South D7
CRTN	Creighton (Hobart and Russell) Hall of Animal Sciences F9	PFEN	Pfendler (David C.) Hall of Agriculture G8	OWEN	Owen (Richard) Residence Hall E4
† DANL	Daniel (William H.) Turfgrass Research Center B1	PFSB	Physical Facilities Service Building F12	PKRF	Parker (Frieda) Residence Hall (formerly Griffin Residence Halls) E6
DAUC	Dauch (Dick and Sandy) Alumni Center H9	PGSC	Purdue Graduate Student Center H5	PKRW	Parker (Winifred) Residence Hall (formerly Griffin Residence Halls) E6
DLR	Hall for Discovery and Learning Research E9	■	Pharmacy (Purdue University Retail Pharmacy - RHPH) G5	PVAB	Purdue Village Administration Building D9
DMNT	DeMent (Clayton W.) Fire Station D6	PHYS	Physics Building G5	PVCC	Purdue Village Community Center C8
DOYL	Doyle (Leo Philip) Laboratory G10	PJEC	Jischke (Patty) Early Care and Education Center C8	PVIL	Purdue Village C, D9, 10
DRUG	Drug Discovery F9	PMRI	Purdue Magnetic Resonance Imaging Facility G9	* SHLY	Shealy (Frances M.) Residence Hall E7
DSCB	Data Science G6	PMU	Purdue Memorial Union H7	SHRV	Shreve (Eleanor B.) Residence Hall D7
DUDL	Dudley Hall H6	PMUC	Purdue Memorial Union Club H7	SMLY	Smalley (John C.) Center for Housing and Food Services Administration D6
DYE	Pete Dye Clubhouse C1	POTR	Potter (A.A.) Engineering Center H6	TARK	Tarkington (Newton Booth) Residence Hall E5
ECEC	Purdue University Early Care and Education Center A7	PRCE	Peirce Hall G7	* VAWT	Vawter (Everett B.) Residence Hall E6
EEL	Entomology Environmental Laboratory G8	PRSV	Printing Services Facility F11	* WARN	Warren (Martha E. and Eugene K.) Residence Hall E7
EHSA	Equine Health Sciences Annex G10	PSYC	Psychological Sciences Building G6, 7	WDCT	Wiley Dining Court E6
EHSB	Equine Health Sciences Building G10	PTCA	Purdue Technology Center Aerospace A8 (West Campus inset)	WILY	Wiley (Harvey W.) Residence Hall E6
ELLT	Elliott (Edward C.) Hall of Music G6	PUSH	Purdue University Student Health Center F, G5	* WOOD	Wood (Elizabeth G. and William R.) Residence Hall E7
FLEX	Flex Laboratories D9	PVAB	Purdue Village Administration Building D9		
FOPN	Flight Operations Building B11	RAIL	American Railway Building H6	Northwest Athletic Complex (C2-3 inset)	
FORS	Forestry Building G8	RAWL	Rawls (Jerry S.) Hall H8	BBCH	Purdue Baseball Clubhouse
FPRD	Forest Products Building G8	RHPH	Heine (Robert E.) Pharmacy Building G5	BBPB	Purdue Baseball Press Box
FRNY	Forney Hall of Chemical Engineering G5	SC	Stanley Coulter Hall G7	SBCH	Purdue Softball Clubhouse
FWLR	Fowler (Harriet O. and James M., Jr.) Memorial House E7	SCHM	Helen B. Schleman Hall G7	SBPB	Purdue Softball Press Box
GCMB	Golf Course Maintenance Barn C2	SCHO	Global Policy Research Institute (Schowe House) F1	SCHW	Schwartz (Dennis J. and Mary Lou) Tennis Center
GMF	Grounds Maintenance Facility F11	SCPA	Slayter Center of Performing Arts E4	SOCC	Purdue Women's Soccer Building
GMGF	Grounds Maintenance Greenhouse Facilities E11	SIML	Holleman-Niswonger Simulator Center A11		
■	The Graduate School (Young Hall - first floor) H8	SMLY	Smalley (John C.) Center for Housing and Food Services Administration D6		
■	Grand Prix Track (see Northwest Athletic Complex Inset)	SMTH	Smith Hall F8		
GRIS	Grissom Hall H7	SOIL	Soil Erosion Laboratory, National E9		
GRS	Grounds Service Building E8	SPUR	Spurgeon (Tom) Golf Training Center C1		
GSMB	Golf Storage Maintenance Building C2	STDM	Ross-Ade Stadium (includes Ross-Ade Pavilion [RAP]) F3		
HAAS	Haas (Felix) Hall G7	STEM	See CHAS G6		
HAGL	Hagle (Marc and Sharon) Hall F6	STEW	Stewart Center (includes Welcome Center) H7		
HAMP	Hampton (Delon and Elizabeth) Hall of Civil Engineering G5	STON	Stone (Winthrop E.) Hall G8		
HANS	Hansen (Arthur G.) Life Sciences Research Building F9	■	Student Health Center (see PUSH) G5		
HEAV	Heavilon Hall H7	TEL	Telecommunications Building F7		
HERL	Herrick Acoustics E8	TERM	Terminal Building B11		
HGR4-7	Hangars, Numbers 4 through 7 A11,12	TERY	Terry (Oliver P.) House E8, 9		
HGRH	Horticultural Greenhouse G9	TREC	Turf Recreation Exercise Center D6		
HIKS	Hicks (John W.) Undergraduate Library H8	TSWF	Transportation Service Wash Facility G12		
HLAB	Herrick Laboratories E8	UC	University Church I7		
HMMT	Hazardous Materials Management Trailer H11	UNIV	University Hall G7		
HNLY	Hanley (Bill and Sally) Hall E7	UPOB	Utility Plant Office Building H11		
HOCK	Hockmeyer (Wayne T. and Mary T.) Hall of Structural Biology E9	UPOF	Utility Plant Office Facility H10		
HORT	Horticulture Building G9	UPSB	Utility Plant Storage Building G11		
HOVD	Hovde (Frederick L.) Hall of Administration G6	VA1	Veterinary Animal Isolation Building 1 G10		
HULL	Hull All-American Marching Band D6	VA2	Veterinary Animal Isolation Building 2 G10		
JNSN	Johnson (Helen R.) Hall of Nursing G6	VCPR	Veterinary Center for Paralysis Research G10		
KCTR	Krannert Center for Executive Education and Research H8				
KFPC	Kozuch Football Performance Complex F3				
KNOY	Knoy (Maurice G.) Hall of Technology H6				

* Windsor Residence Halls

† Part of Maurice J. Zucrow Laboratories

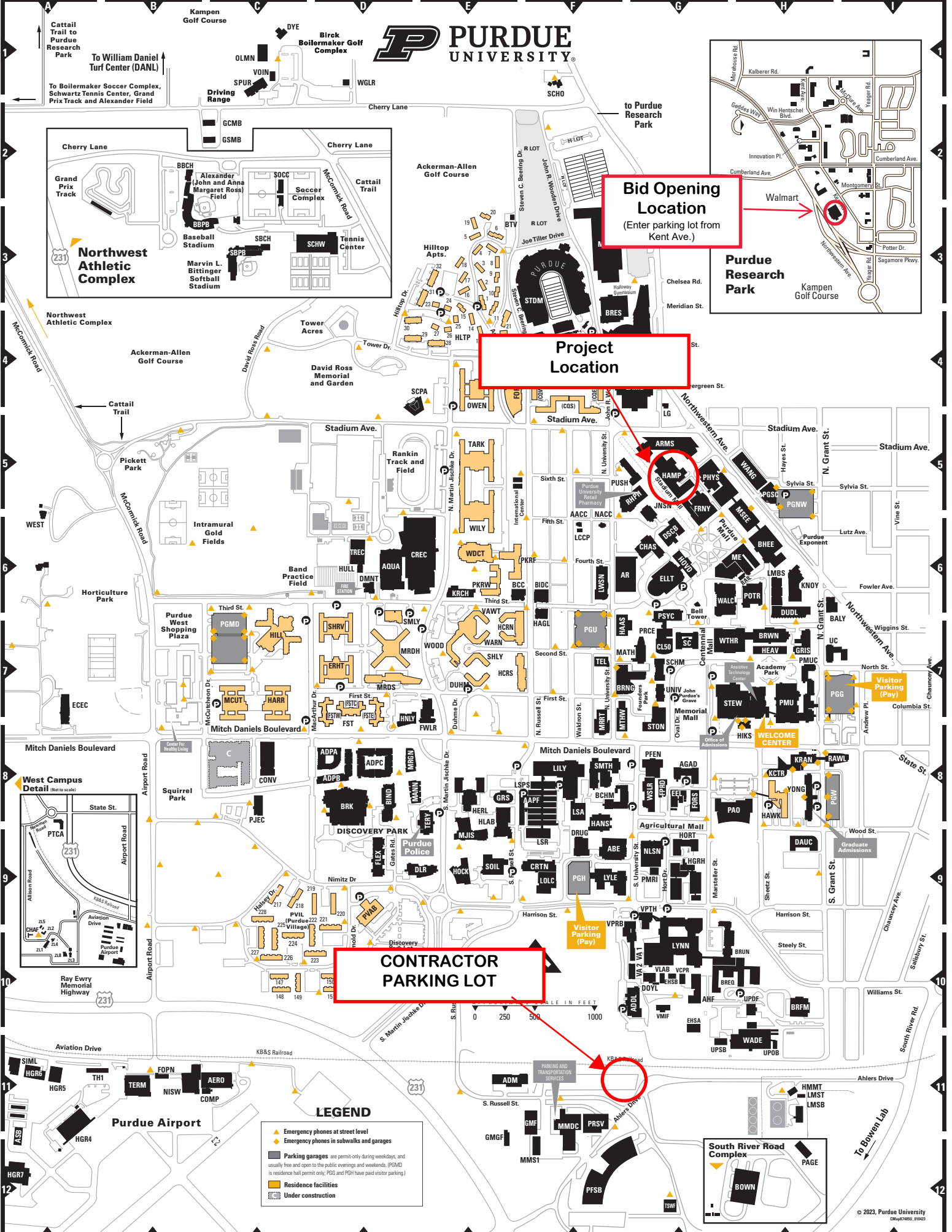

Bid Opening Location
(Enter parking lot from Kent Ave.)

Project Location

CONTRACTOR PARKING LOT

- LEGEND**
- ▲ Emergency phones at street level
 - ▲ Emergency phones in subwalks and garages
 - Parking garages are permit-only during weekdays, and usually free and open to the public evenings and weekends. (PGMD is residence hall permit only; PGH and PGH have paid visitor parking.)
 - Residence facilities
 - Under construction

SECTION 01 0100 - PROJECT REQUIREMENTS

SECTION 01 0100 - PROJECT REQUIREMENTS

PART 1: GENERAL

1.01 SCOPE OF PROJECT

- A. The project is the renovation of two (2) existing rooms in Hampton Hall for use as laboratory spaces. Scope includes selective demolition, laboratory casework, finishes, coordination and connection with a new rooftop exhaust equipment being installed in a separate contract, and new electrical and plumbing distribution to accommodate new laboratory layout.
- B. Contract: Construction work under unified fixed price contract.

1.02 PROJECT MANAGER

- A. Project Manager for this project is Mike Greene, Physical Facilities, Purdue University, (765) 336-9366

1.03 COMMENCEMENT AND COMPLETION OF THE WORK

- A. Refer to the General Conditions of the Contract, Article 8.
- B. Work on the project shall begin immediately following Award of Contract and must be completed no later than January 31, 2025.
- C. Prior to the Owner's preparation of a Project Punch List, the Contractor shall prepare his own punch list and submit to the Owner.

1.04 JOBSITE VISITS

- A. Any Bidder wishing to make on-site job visits to inspect and verify conditions shall contact Mike Greene, Senior Project Manager, (765) 336-9366, to make arrangements.
- B. All questions about the Contract Documents shall be directed to the Architect of Record.

1.05 PAYMENT

- A. See General Conditions of the Contract, Article 9.

1.06 CONTRACTOR'S USE OF PREMISES

- A. Contractor(s) shall confine his use of premises to the limits of construction shown on the Drawings or as directed by the Owner's Project Manager.

SECTION 01 0100 - PROJECT REQUIREMENTS

1. Use of premises for work and storage shall be limited to allow for Owner's occupancy.
 2. Access to the project area shall be coordinated with the Owner's Project Manager.
- B. Assume full responsibility for protection and safe keeping of products stored on premises.
- C. See Section "Temporary Facilities and Controls" for storage within existing buildings.

1.07 CONTRACTOR PARKING

- A. Contractor shall purchase needed contractor parking permits through Purdue University Parking Facilities office. See www.purdue.edu/parking for details.
1. Parking at the Project Site: 2 spaces will be available within the proximity of the Project Site. These parking spaces require green "Contractor Parking" permits and a location to be determined by the Purdue Project Manager. These permits shall be requested by the Contractor through the Purdue Project Manager. Contractor shall submit the approved request form to Parking Facilities to purchase the permit.
 2. Contractor Personnel Parking: Contractor personnel shall park in the Contractor Parking Lot located east of the airport (see map). An orange "Contractor Personnel" parking permit is required for this lot. These permits may be purchased by the Contractor without Purdue Project Manager involvement.

1.08 OWNER'S OCCUPANCY

- A. It shall be understood that all occupied buildings in the project area shall operate in a normal manner, without disruption of essential services to the satisfaction of the Owner during construction operations.
- B. Suitable means of ingress and egress shall be maintained to these areas at all times.
- C. Cooperate with Owner in all construction operations to minimize conflict and to facilitate Owner's usage.
- D. If a dispute over time of use or interruption of use of the facilities develop, the Owner's requirements shall take precedence.

1.09 PROTECTION

- A. Existing Property:
1. Protect existing property from damage during the work required by these Contract Documents. Any damage done to existing property shall be repaired satisfactorily to the approval of the Owner.

SECTION 01 0100 - PROJECT REQUIREMENTS

2. Existing property includes, but shall not be limited to, buildings, sidewalks, curbs, lawns, grass and shrubs.
- B. Work in Progress:
1. In the event of temporary suspension of work for inclement weather or for any other reasons, the Contractor shall protect all work and materials against damage or injury. If damage or injury results from failure to protect, such work and materials shall be removed and replaced at no additional cost to the Owner.
- C. Utilities:
1. All existing water and gas pipe, sewers, drains, electrical ducts and other duly authorized structures shall be properly supported and protected by and at the expense of the Contractor during the construction of work under or near them and so as not to interfere with their use. They shall be left in as good condition on completion of the work as when found by the Contractor.
- 1.10 ASBESTOS AFFIDAVIT
- A. As a part of the project close-out documentation, the Contractor, each of his Subcontractors and each of the material suppliers shall sign an affidavit stating that no materials containing asbestos have been used and/or installed on this project.
- 1.11 SMOKE-FREE CAMPUS POLICY
- A. As per Purdue University's Smoke-Free Campus Policy effective July 1, 2010, smoking is prohibited on campus except in designated smoking areas. Construction job sites must comply with this policy.
- B. A map of the designated smoking areas on campus may be requested at the pre-construction meeting.
- C. Smoking is only permitted in the designated areas or inside privately owned, closed vehicles.
- 1.12 UTILITY TUNNELS AND BUILDING LATERALS
- A. The utility tunnels and building laterals are classified as a confined space (not a permit required confined space) under normal operating conditions. Prior to commencing its work, Contractor shall determine whether the area should be reclassified to a permit required confined space due to the Contractor's performance of hot work, painting or any other action. Contractor shall communicate any such determination in writing to the Project Manager and take all action necessary to ensure worker health and safety including compliance with any applicable safety regulation and the Contractor's own safety guidelines.

SECTION 01 0100 - PROJECT REQUIREMENTS

END OF SECTION 01 0100

SECTION 01 2900 – PAYMENT PROCEDURES

SECTION 01 2900 – PAYMENT PROCEDURES

PART 1: GENERAL

1.01 RELATED DOCUMENTS

- A. Drawings and general provisions of the Contract, including General and Supplementary Conditions and other Division 1 Specification Sections, apply to this Section.

1.02 SCHEDULE OF VALUES

- A. Coordination: Coordinate preparation of the Schedule of Values with preparation of Contractor's Construction Schedule
- B. Format and Content: Use the Project Manual table of contents as a guide to establish line items for the Schedule of Values. Provide at least one line item for each Specification Section
 - 1. Breakdown shall include separate line items for material and labor for Divisions 2 through 48.
 - 2. Round amounts to nearest whole dollar.
 - 3. O&M and As Built Drawings shall be listed as a separate item in the Schedule of Values with a value of 3% of the contract sum but not less than \$1,000 or more than \$250,000.
 - 4. Provide a separate line item in the Schedule of Values for each Allowance, if applicable.

1.03 APPLICATIONS FOR PAYMENT

- A. Each Application for Payment shall be consistent with previous applications and payments as certified and paid for by Owner.
- B. Pencil copies of Application for Payment shall be submitted to the Owner's Representative and Purdue Project Manager for approval (5) days prior to formal submission.
- C. Payment Application Forms: use forms provided by Owner for Applications for Payment.
 - 1. Include amounts of Change Orders approved before last day of construction period covered by application.
- D. Transmittal: Submit a signed and notarized original copy of each Application for Payment to Purdue University. Include all required attachments described or prescribed elsewhere in the Contract Documents.
- E. Initial Application for Payment: Administrative actions and submittals that must precede or coincide with submittal of first Application for Payment include the following:

SECTION 01 2900 – PAYMENT PROCEDURES

1. Schedule of Subcontractors, Manufacturers and Products.
 2. Schedule of Values
 3. Contractor's Construction Schedule.
 4. Submittal Schedule.
 5. List of Contractor's staff and principal assignments.
 6. Copies of building permits and other authorizations for performance of the Work.
 7. Certificates of insurance and insurance policies.
 8. Certified Schedule of Wages or Certified Payroll, if required.
- F. Application for Payment at Substantial Completion: After issuing the Certificate of Substantial Completion, submit an Application for Payment showing 100 percent completion for portion of the Work claimed as substantially complete.
1. This application shall reflect Certificates of Partial Substantial Completion issued previously for Owner occupancy of designated portions of the Work.
- G. Final Payment Application: Submit final Application for Payment with releases and supporting documentation not previously submitted and accepted, including, but not limited, to the following:
1. Evidence of completion of Project closeout requirements.
 2. Insurance certificates for products and completed operations where required and proof that taxes, fees, and similar obligations were paid.
 3. Final statement, accounting for final changes to the Contract Sum.
 4. Contractor's Affidavit, Waiver of Lien, and Guarantee.
 5. Evidence that claims have been settled.
 6. Final, liquidated damages settlement statement.

PART 2 – PRODUCTS (Not Used)

PART 3 – EXECUTION (Not Used)

END OF SECTION 01 2900

SECTION 01 3100 – PROJECT MANAGEMENT AND COORDINATION

SECTION 01 3100 – PROJECT MANAGEMENT AND COORDINATION

PART 1: GENERAL

1.01 RELATED DOCUMENTS

- A. Drawings and general provisions of the Contract, including General and Supplementary Conditions and other Division 1 Specification Sections, apply to this Section.

1.02 SUMMARY

- A. This Section includes administrative provisions for coordinating construction operations on Project.

1.03 COORDINATION

- A. Coordination: Coordinate construction operations included in various Sections of the Specifications to ensure efficient and orderly installation of each part of the Work. Coordinate construction operations, included in different Sections that depend on each other for proper installation, connection, and operation.
 - 1. The layout of fire protection, plumbing, mechanical, and electrical systems, equipment, fixtures, piping, ductwork, conduit, specialty items, accessories shown on the drawings and in diagrammatic form, and all variations in alignment, elevation and details required to avoid interferences and satisfy all architectural and structural limitations are not necessarily shown.
 - 2. Actual layout of the Work shall be carried out without affecting the architectural or structural integrity and limitations of the Work and shall be performed in such sequence and manner as to avoid conflicts, provide clear access to all control points, including valves, strainers, control devices and specialty items of every nature related to such systems and equipment, obtain maximum headroom, and provide clearances as required for operation and maintenance.
- B. Administrative Procedures: Coordinate scheduling and timing of required administrative procedures with other construction activities and activities of other contractors to avoid conflicts and to ensure orderly progress of the Work. Such administrative activities include, but are not limited to, the following:
 - 1. Preparation of Contractor's Construction Schedule.
 - 2. Preparation of the Schedule of Values.
 - 3. Installation and removal of temporary facilities and controls.
 - 4. Delivery and processing of submittals.
 - 5. Progress meetings.
 - 6. Pre-installation conferences.
 - 7. Project closeout activities.

SECTION 01 3100 – PROJECT MANAGEMENT AND COORDINATION

- C. Conservation: Coordinate construction activities to ensure that operations are carried out with consideration given to conservation of energy, water, and materials.

1.04 SUBMITTALS

- A. Construction Schedule: Submit a comprehensive, horizontal bar chart or CPM construction schedule within 10 days of the Notice to Proceed.
- B. Preparation: Indicate each significant construction activity separately. Identify first workday of each week with a continuous vertical line.

1.05 PROJECT MEETINGS

- A. General: Schedule and conduct meetings and conferences at Project site, unless otherwise indicated.
 - 1. Attendees: Inform participants and others whose presence is required, of date and time of each meeting. Notify Owner and Architect of dates and times.
 - 2. Minutes: Record and distribute the meeting minutes to everyone concerned within five days of the meeting.
- B. Preconstruction Conference: A/E will schedule a preconstruction conference before starting construction, at a time convenient to Owner and Architect, at Project site or another convenient location.
 - 1. Agenda: Discuss items of significance that could affect progress, including the following:
 - a. Tentative construction schedule.
 - b. Phasing/Critical work sequencing.
 - c. Designation of responsible personnel.
 - d. Procedures for processing field decisions and Change Orders.
 - e. Procedures for processing Applications for Payment.
 - f. Submittal procedures.
 - g. Preparation of Record Documents.
 - h. Use of the premises.
 - i. Responsibility for temporary facilities and controls.
 - j. Parking availability.
 - k. Office, work, and storage areas.
 - l. Equipment deliveries and priorities.
 - m. Security.
 - n. Progress cleaning.
 - o. Working hours.
- C. Pre-installation Conferences: Conduct a pre-installation conference at Project site before each construction activity that requires coordination with other construction.

SECTION 01 3100 – PROJECT MANAGEMENT AND COORDINATION

1. Attendees: Installer and representatives of manufacturers and fabricators involved in or affected by the installation and its coordination or integration with other materials and installations that have preceded or will follow, shall attend the meeting.
 2. Agenda: Review progress of other construction activities and preparations for the particular activity under consideration, including requirements for the following:
 - a. Deliveries.
 - b. Submittals and mockups.
 - c. Possible conflicts, substrate acceptability and compatibility problems.
 - d. Time and weather limitations.
 - e. Manufacturer's written recommendations.
 - f. Warranty requirements.
 - g. Space and access limitations.
 - h. Regulations of authorities having jurisdiction.
 - i. Testing and inspecting requirements and required performance results.
 3. Record significant conference discussions, agreements, and disagreements.
 4. Do not proceed with installation if the conference cannot be successfully concluded. Initiate whatever actions are necessary to resolve impediments to performance of the Work and reconvene the conference at earliest feasible date.
- D. Progress Meetings: Contractor will conduct progress meetings at bi-weekly intervals.
1. Attendees: In addition to representatives of Owner and Architect, each contractor, subcontractor, supplier, and other entity concerned with current progress or involved in planning, coordination, or performance of future activities shall be represented at these meetings. All participants at the conference shall be familiar with Project and authorized to conclude matters relating to the Work.
 2. Agenda: Review and correct or approve minutes of previous progress meeting. Review other items of significance that could affect progress. Review the present and future needs of each entity present, including such items as:
 - a. Contractor's Construction Schedule: Review progress since the last meeting. Determine whether each activity is on time, ahead of schedule, or behind schedule, in relation to Contractor's Construction Schedule. Determine how construction behind schedule will be expedited; secure commitments from parties involved to do so. Discuss whether schedule revisions are required to ensure that current and subsequent activities will be completed within the Contract Time.
 - b. Interface requirements
 - c. Time and sequences
 - d. Access and Site utilization
 - e. RFI's, Submittals, Change Orders
 - f. Off-site fabrication problems
 - g. Housekeeping
 - h. Quality and Work Standards

SECTION 01 3100 – PROJECT MANAGEMENT AND COORDINATION

- i. Documentation of information for payment requests
 - j. Hours of work
 - k. Schedule Updating: Contractor shall revise its Construction Schedule after each progress meeting where revisions to the schedule have been made or recognized. Issue revised schedule at the next meeting. The schedule baseline shall be maintained throughout the life of the project and used to compare against the actual progress of the work.
- E. Contractor Coordination Meetings: Conduct Project coordination meetings at weekly intervals and as needed for the resolution of unanticipated issues. Project coordination meetings are in addition to specific meetings held for other purposes, such as progress meetings and pre-installation conferences.
- 1. Reporting: Record meeting results and distribute copies to everyone in attendance, Owner and Architect, and others affected by decisions or actions resulting from each meeting.

PART 2: PRODUCTS (Not Used)

PART 3: EXECUTION (Not Used)

END OF SECTION 01 3100

SECTION 01 3216 – CONSTRUCTION PROGRESS SCHEDULES

SECTION 01 3216 – CONSTRUCTION PROGRESS SCHEDULES

PART 1: GENERAL

1.01 RELATED DOCUMENTS

- A. Drawings and general provisions of the Contract, including General and Supplementary Conditions and other Division 1 Specification Sections, apply to this Section.

1.02 SUMMARY

- A. The contractor will create a construction schedule of the Critical Path Method (CPM) type to monitor the project. The contractor will be responsible for providing all information concerning the sequencing and durations of all activities as well as providing the initial CPM logic diagram. Once the initial logic diagram is accepted by Purdue University, the contractor will be responsible for maintaining and providing periodic updates.
- B. If the scope is on multiple levels of a building, each level will be broken out. The electrical, mechanical and general scope will be detailed separately.
- C. This schedule shall be the Contractor's working schedule and used to plan, organize and execute the work, record and report actual performance and progress and outlines how the Contractor plans to complete all remaining work.

1.03 SUBMITTALS

- A. Within ten (10) days after notice of award of contract, the Contractor shall submit for review and approval a framework schedule, along with a work breakdown structure and activity code breakdown structure, and a 60 day detailed schedule. The schedule will be reviewed by Purdue University and returned to the Contractor within fourteen (14) days. Receipt and review of the schedule is a requirement for issuance of the first progress payment.
- B. Within forty-five (45) days after notice of award of the contract, the Contractor shall submit for review and approval the completed schedule, incorporating the 60 day schedule. Progress payments are contingent upon approval of the completed schedule.
- C. Updates of the schedule and the Excel spreadsheet will be sent to Purdue University on the last Friday of every month. Once Red-Zone is reached, updates become required every Friday. Updates are to be delivered in electronic format. Updates are required in electronic schedule software format.

SECTION 01 3216 – CONSTRUCTION PROGRESS SCHEDULES

PART 2: PRODUCTS

2.01 SOFTWARE

- A. The following software packages are acceptable:
 - 1. Primavera Project Planner (P6 XER format)
 - 2. Primavera Suretrack
 - 3. Microsoft Project
- B. Owner supported activities shall be updated in Microsoft Excel format matching the spreadsheet format given to the Contractor.

PART 3: EXECUTION

3.01 NETWORK DETAILS

- A. Detailed Network Diagram: The detailed network diagram shall show all activities required to complete the project and their dependency relationships. Include intermediate milestones as necessary to track important events such as phased completion dates, permanent power, outages, owner furnished equipment delivery, etc., and all items specified in the "Other Conditions" of the contract. Each activity should have an associated activity identification, activity description, duration, early and late start and finish dates, and total float. Logic relationships may include start-to-start, start-to-finish, and finish-to-finish with lags times as required. Finish-to-start lags are not allowed. Start-to-start lags shall be no longer than ten (10) days. Each activity shall have at least one precedent and/or successor activity.
- B. Calendar: List all non-work days to include weekends and holidays. Include other days that university personnel will not be available (refer to current University Academic calendar).
- C. Required Activities: Activities to be included in the network shall be: construction activities; submittal/shop drawing preparation activities; submittal/shop drawing review activities; purchase, manufacture/fabricate, and delivery for major equipment and materials activities; critical inspection activities; utility shutdown activities; and close-out activities.
 - 1. The Contractor will be given a disk with a Microsoft Excel file containing a list of the required milestones. This list of the required milestones is attached in this Specification Section as Attachment "A". The Contractor may add to this list, but may not delete any milestones from it.

SECTION 01 3216 – CONSTRUCTION PROGRESS SCHEDULES

D. Activity Detail: The activities shall meet the following criteria:

1. Unique numbering system to include project number and CSI coding. Include coding for building, phase, area, sub-area, floor, contractor, subcontractor as applicable. Coordinate coding with schedule of values.
2. Whole day units.
3. Construction activities shall have a maximum duration of 15 days.
4. Resource loading in man-hours for each activity. Include proposed resource flow of subcontractors through the building.

3.02 UPDATING

A. The updates will cover the project schedule and the milestones. Update will be compared to the baseline schedule (or accepted revised baseline schedule). Previous months' schedule update will not be used. Update shall include as a minimum the following:

1. Actual start/finish dates
2. Projected remaining durations for activities in progress
3. Logic changes to correct out-of-sequence progress only
4. Narrative to include: reasons for changes and associated impact, progress on the critical path and critical path shifting, total float usage, average number of days activities started early/late, activities which did not start but should have, added/deleted activities.
5. If schedule has slipped, a recovery schedule indicating the logic changes and duration changes required to recover the schedule.

3.03 CHANGE ORDERS

F. If a change in scope influences the project schedule, then a revised project schedule will be submitted with the request for change in contract amount. This revised project schedule will show the change or delay on the current contract schedule completion date. This revised project schedule shall be submitted by the Contractor for review by Purdue University.

END OF SECTION 01 3216

SECTION 01 3523 – OWNER SAFETY REQUIREMENTS

SECTION 01 3523 – OWNER SAFETY REQUIREMENTS

PART 1 - GENERAL

1.01 SUMMARY

- A. Contractor performing work at the Project site shall demonstrate commitment to workplace safety, safe work practices, and compliance with all applicable safety requirements by one or more of the following methods while working on this project and shall be participating members in one of the following programs:
 - 1. Engaged in an active consultation with IOSHA's INSafe Program for this Project;
 - 2. Establish and maintain a level of "participating" or better in the Coalition for Construction Safety (CCS) Certification Program; or
 - 3. Establish and maintain a "participating" membership status in IDOL/ICA's or IDOL/ABC's Safety Partnership Program.

1.02 SUBMITTALS

- A. Contractor will provide documentation of participation to owner prior to award of contract.
- B. Documentation of participation in a safety program shall be in such form as follows for each program:
 - 1. INSafe Program – employer's INSafe consultation confirmation for the project specifically stated in this contract. Contractor shall provide a copy of the confirmation from INSafe that a consultation has been requested, copies of the confirmation of the visit, and any findings by INSafe.
 - 2. Coalition for Construction Safety (CCS) – participating level will be obtained from the CCS database.
 - 3. IDOL Safety Partnership Programs – letter from the Directors of ICA/ABC attesting to the contractor's participation in the IDOL Safety Partnership Program.

PART 2 – PRODUCTS (Not Used)

PART 3 – EXECUTION (Not Used)

END OF SECTION 01 3523

SECTION 01 5000 – TEMPORARY FACILITIES AND CONTROLS

SECTION 01 5000 – TEMPORARY FACILITIES AND CONTROLS

PART 1: GENERAL

1.01 RELATED DOCUMENTS

- A. Drawings and general provisions of the Contract, including General and Supplementary Conditions and other Division 1 Specification Sections, apply to this Section.

1.02 SUMMARY

- A. This Section includes requirements for temporary facilities and controls, including temporary utilities, support facilities, and security and protection facilities as may be indicated on the Drawings and as specified herein.

1.03 DESCRIPTION

- A. Temporary Electrical Power:
 - 1. Obtain from Owner's existing service.
 - 2. Furnish, install and maintain a temporary wiring system for construction power and light for all trades.
- B. Temporary Heat and Ventilation:
 - 1. Protect work and products against dampness and cold.
 - 2. Provide suitable ambient temperatures for installation and curing of materials.
 - 3. Provide adequate ventilation for safe working environment health regulations.
- C. Temporary Water:
 - 1. Owner's existing service.
 - 2. Coordinate with Owner's Project Manager for point of source.
 - 3. Provide testable, reduced pressure type backflow preventers.
 - a. Owner will test the backflow preventers before they are connected to a potable water source to ensure correct type, lead-free, and correct installation.
 - b. Contractor shall retest backflow preventers after any relocation. Testing reports shall be submitted to Project Manager.
- D. Temporary Telephone:
 - 1. General Contractor provides service of desired.
 - 2. Subcontractors provide service they require.
 - 3. Owner's telephone shall not be available for use, except for emergencies.
- E. Sanitary Facilities:
 - 1. Owner's existing restroom facilities are available for use. If the facilities become abused the contractor will be asked to provide their own portable facilities.

SECTION 01 5000 – TEMPORARY FACILITIES AND CONTROLS

1.04 COSTS OF TEMPORARY UTILITIES

- A. Temporary Electrical Power:
 - 1. Make all necessary arrangements.
 - 2. Pay for setting, distributing, maintaining, and removing temporary facilities.
 - 3. Owner will furnish and pay cost of power.

- B. Temporary Heat and Ventilation:
 - 1. Pay costs of installation, operation, maintenance, and removal.
 - 2. Pay costs of filter replacement.
 - 3. Contractor shall furnish and pay cost of fuels.

- C. Temporary Water:
 - 1. Pay costs for installing, maintaining, and removing pipe and equipment.
 - 2. Water will be supplied by the Owner.
 - 3. Owner will pay cost of initial testing of backflow preventers.
 - 4. Pay costs for retesting of relocated backflow preventers.

- D. Temporary Telephone:
 - 1. Pay costs of installation, maintaining, and removing temporary service.
 - 2. Pay for local telephone service.
 - 3. Persons making toll calls pay charges.

1.05 PROJECT CONDITIONS

- A. Temporary Utilities: At earliest feasible time, when acceptable to Owner, change over from use of temporary service to use of permanent service.
 - 1. Temporary Use of Permanent Facilities: Installer of each permanent service shall assume responsibility for operation, maintenance, and protection of each permanent service during its use as a construction facility before Owner's acceptance, regardless of previously assigned responsibilities.

- B. Conditions of Use: The following conditions apply to use of temporary services and facilities by all parties engaged in the Work:
 - 1. Keep temporary services and facilities clean and neat.
 - 2. Relocate temporary services and facilities as required by progress of the Work.

1.06 GENERAL PROVISIONS

- A. Furnish and maintain during the construction period temporary requirements and facilities and perform temporary Work as required in the performance of this Contract. Upon completion of the Work, all temporary facilities shall be removed and the premises left clean.

- B. General: Provide new materials. Undamaged, previously used materials in serviceable condition may be used. Provide materials suitable for use intended.

SECTION 01 5000 – TEMPORARY FACILITIES AND CONTROLS

- C. Ingress and Egress:
 - 1. Ingress and egress to the Project construction areas shall be determined by the Owner's Project Manager.
 - 2. Contractors shall not damage any drives, curbs, sidewalks and other site improvements that remain in place.
 - a. Materials and items which are not designated to be removed and are damaged shall be removed and replaced with new materials which match existing.
 - 3. Such means of ingress and egress must take into account that the entrances to existing and adjacent buildings and related access ways must remain open, in operation, unobstructed and available for normal daily operations (and possible emergency exit).
 - 4. Obtain permission from the Owner's Project Manager where necessary to drive a vehicle of any sort over a curb and gutter and onto a sidewalk and on or across a utility tunnel. Such permission will only be granted after an inspection of the areas involved is made. Any damages resulting from passage of vehicles of any sort over curbs, gutters and sidewalks shall be repaired by the contractor at his own expense. Driving of any vehicle over curbs and gutters onto sidewalks without permission will be considered to have been the cause of any flaws found and the contractor shall repair them at his expense.

- D. Access to Existing Adjacent Buildings:
 - 1. The Contractor shall caution all workmen regarding blocking of roadways, illegal parking, blocking of loading docks and blocking of existing facilities from buildings.
 - 2. Throughout the construction period, emergency vehicles routes and access to service entrances of adjacent buildings must be maintained.
 - 3. Coordinate any temporary shutdown of drives or entrances with the Owner.

- E. Maintaining the Use of Existing Adjacent Buildings:
 - 1. It shall be understood that all existing adjacent buildings shall operate in a normal manner, without disruption of essential services to the satisfaction of the Owner during construction operations.

- F. Maintaining Existing Building Security
 - 1. Secure the Project against the entrance of unauthorized persons through construction areas.
 - 2. Maintain proper closures at any openings required in the present exterior walls accommodate construction operations and the sequence of work.

- G. Protecting Existing Materials, Finishes and Mechanical and Electrical
 - 1. All existing materials and finishes designated to remain shall be protected from damage by construction operations and from the elements during the entire period of construction operations. Any existing materials, finishes, mechanical and electrical installations damaged by construction operations or by the elements shall be repaired or replaced as necessary, at no cost to the Owner and to the approval of the Owner's Project Manager.

SECTION 01 5000 – TEMPORARY FACILITIES AND CONTROLS

- H. Storage of Materials:
 - 1. The Contractor shall confine storage of materials within the contract work area as directed by the Owner's Project Manager.
 - 2. Contractor shall be responsible for assigning locations and space for each subcontractor's storage and staging area.
 - 3. Make arrangements for use of all storage areas with Owner's Project Manager.
- I. Signs: The use of signs on the project shall be as approved by the Owner's Project Manager.
- J. Demolition Dust Control: The Contractor shall utilize appropriate dust containment and barriers during demolition activities. The Contractor will provide negative air unit(s) for the Contractor's use during demolition to meet the project requirements.
- K. Chain-Link Fencing: Minimum 2-inch 9-gage, galvanized steel, chain-link fabric fencing; minimum 6 feet high with galvanized steel pipe posts; minimum 2-3/8-inch- OD line posts and 2-7/8-inch- OD corner and pull posts. (Plastic fence is prohibited from being used on campus.)
- L. Tarpaulins: Fire-resistive labeled with flame-spread rating of 15 or less.
- M. Water: Potable

PART 2: PRODUCTS

2.01 EQUIPMENT

- A. Fire Extinguishers: Hand carried, portable, UL rated. Comply with NFPA 10 and NFPA 241 for classification, extinguishing agent, and size required by location and class of fire exposure.
- B. Drinking-Water Fixtures: Containerized, tap-dispenser, bottled-water drinking-water units, including paper cup supply.
- C. Heating Equipment: Unless Owner authorizes use of permanent heating system, provide vented, self-contained, liquid-propane-gas or fuel-oil heaters with individual space thermostatic control.
 - 1. Use of gasoline-burning space heaters, open-flame heaters, or salamander-type heating units is prohibited.
 - 2. Heating Units: Listed and labeled, by a testing agency acceptable to authorities having jurisdiction, and marked for intended use for type of fuel being consumed.
- D. Electrical Outlets: Properly configured, NEMA-polarized outlets to prevent insertion of 110- to 120-V plugs into higher-voltage outlets; equipped with ground-fault circuit interrupters, reset button, and pilot light.

SECTION 01 5000 – TEMPORARY FACILITIES AND CONTROLS

- E. Power Distribution System Circuits: Where permitted and overhead and exposed for surveillance, wiring circuits, not exceeding 125-V ac, 20-A rating, and lighting circuits may be nonmetallic sheathed cable.
- F. Roof Harness and Tie-Off Line: Provide harness and tie-off line in accordance with Contractor's sole responsibility for conformance with OSHA requirements for construction.

2.02 SECURITY AND PROTECTION FACILITIES INSTALLATION

- A. Environmental Protection: Provide protection, operate temporary facilities, and conduct construction in ways and by methods that comply with environmental regulations and that minimize possible air, waterway and subsoil contamination or pollution or other undesirable effects. Avoid using tools and equipment that produce harmful noise.
- B. Site Enclosure Fence: Before construction operations begin, install chain-link enclosure fence with lockable entrance gates. Locate where indicated, or if not indicated, enclose entire Project site or portion determined sufficient to accommodate construction operations. Install in a manner that will prevent people, dogs, and other animals from easily entering site except by entrance gates.
 - 1. Set fence posts in compacted mixture of gravel and earth.
- C. Security Enclosure and Lockup: Install substantial temporary enclosure around partially completed areas of construction. Provide lockable entrances to prevent unauthorized entrance, vandalism, theft and similar violations of security.
- D. Barricades, Warning Signs and Lights: Comply with standards and code requirements for erecting structurally adequate barricades. Paint with appropriate colors, graphics and warning signs to inform personnel and public of possible hazard. Where appropriate and needed, provide lighting, including flashing red or amber lights.
- E. Fire Protection: Until fire protection is supplied by permanent facilities, the Contractor shall install and maintain temporary fire protection to types needed to protect against predictable and controllable fire losses.
- F. Rodent and Pest Control: Retain an exterminator or pest control company to perform extermination and control procedures so the project will be free of pests at Substantial Completion. Perform operations in a lawful manner using environmentally safe materials.

PART 3: EXECUTION

3.01 INSTALLATION, GENERAL

- A. Install work in neat orderly manner, structurally sound.
- B. Locate facilities where they will serve Project adequately and result in minimum interference with performance of the Work. Relocate and modify facilities as required.

SECTION 01 5000 – TEMPORARY FACILITIES AND CONTROLS

- C. Provide each facility ready for use when needed to avoid delay. Maintain and modify as required. Do not remove until facilities are no longer needed or are replaced by authorized use of completed permanent facilities.
- D. Temporary Enclosures: Provide temporary enclosures for protection of construction, in progress and completed, from exposure, foul weather, other construction operations and similar activities. Provide temporary weather tight enclosure for building exterior.
- E. Temporary Partitions: Erect and maintain dustproof partitions and temporary enclosures to limit dust and dirt migration and to separate areas from fumes and noise.
 - 1. Construction dustproof partitions of not less than nominal 4-inch studs, 2 layers of 3-mil polyethylene sheets, inside and outside temporary enclosure and sealed to floor with tape. Overlap and tape full length of joints.
 - a. Construct a vestibule and airlock at each entrance to temporary enclosure with not less than 48 inches between doors. Maintain water-dampened foot mats in vestibule.
- F. Burning of trash on the site is prohibited.

3.02 TEMPORARY UTILITY INSTALLATION

- A. General: Engage appropriate local utility company to install temporary service or connect to existing service. Where utility company provides only part of the service, provide the remainder with matching, compatible materials and equipment. Comply with utility company recommendations.
- B. Arrange with utility company, Owner, and existing users for time when service can be interrupted, if necessary, to make connections for temporary services.
 - 1. Provide adequate capacity at each stage of construction. Before temporary utility is available, provide trucked-in services.
 - 2. Obtain easements to bring temporary utilities to Project site where Owner's easements cannot be used for that purpose.
- C. Sewers and Drainage: If sewers are available, provide temporary connections to remove effluent that can be discharged lawfully. If sewers are not available or cannot be used, provide drainage ditches, dry wells, stabilization ponds, and similar facilities. If neither sewers nor drainage facilities can be lawfully used for discharge of effluent, provide containers to remove and dispose of effluent off-site in a lawful manner.
 - 1. Filter out excessive soil, construction debris, chemicals, oils, and similar contaminants that might clog sewers or pollute waterways before discharge.
 - 2. Connect temporary sewers to municipal or private system designated by Owner as directed by sewer department officials.
 - 3. Maintain temporary sewers and drainage facilities in a clean, sanitary condition. After heavy use, restore normal conditions promptly.
 - 4. Provide temporary filter beds, settlement tanks, separators, and similar devices to purify effluent to levels acceptable to authorities having jurisdiction.

SECTION 01 5000 – TEMPORARY FACILITIES AND CONTROLS

5. Water Service: Install water service and distribution piping in sizes and pressures adequate for construction until permanent water service is in use. Sterilize temporary water piping before use.
 6. Provide rubber hoses as necessary to serve Project site.
 7. As soon as water is required at each level, extend service to form a temporary water- and fire-protection standpipe. Comply with Owner's requirements, if any, for spacing and characteristics of standpipes. Provide distribution piping. Space outlets so water can be reached with a 100-foot hose.
 8. Where installations below or adjacent to an outlet might be damaged by spillage or leakage, provide a drip pan of suitable size to minimize water damage. Drain accumulated water promptly from pans.
 9. Provide pumps to supply a minimum of 30-psi static pressure at highest point. Equip pumps with surge and storage tanks and automatic controls to supply water uniformly at reasonable pressures.
- D. Sanitary Facilities: When required by the Contract Documents provide temporary toilets, wash facilities, and drinking-water fixtures. Comply with regulations and health codes for type, number, location, operation, and maintenance of fixtures and facilities.
1. Disposable Supplies: Provide and maintain toilet tissue, paper towels, paper cups, and similar disposable materials for each facility.
 2. Toilets: Install self-contained toilet units.
 3. Wash Facilities: Install wash facilities supplied with potable water at convenient locations for personnel who handle materials that require wash up. Dispose of drainage properly. Supply cleaning compounds appropriate for each type of material handled.
 4. Drinking-Water Facilities: Provide bottled-water, drinking-water units.
- E. Heating and Cooling: Provide temporary heating and cooling required by construction activities for curing or drying of completed installations or for protecting installed construction from adverse effects of low temperatures or high humidity.
1. Maintain a minimum temperature of 50 deg F in permanently enclosed portions of building for normal construction activities, and 65 deg F for finishing activities and areas where finished Work has been installed.
- F. Ventilation and Humidity Control: Provide temporary ventilation required by construction activities for curing or drying of completed installations or for protecting installed construction from adverse effects of high humidity. Select equipment from that specified that will not have a harmful effect on completed installations or elements being installed. Coordinate ventilation requirements to produce ambient condition required and minimize energy consumption.
- G. Electric Power Service: Provide weatherproof, grounded electric power service and distribution system of sufficient size, capacity, and power characteristics during construction period. Include meters, transformers, overload-protected disconnecting means, automatic ground-fault interrupters, and main distribution switchgear.

SECTION 01 5000 – TEMPORARY FACILITIES AND CONTROLS

- H. Electric Distribution: Provide receptacle outlets adequate for connection of power tools and equipment.
 - 1. Provide metal conduit, tubing, or metallic cable for wiring exposed to possible damage. Provide rigid steel conduits for wiring exposed on grades, floors, decks, or other traffic areas.
 - 2. Provide metal conduit enclosures or boxes for wiring devices.
 - 3. Provide 4-gang outlets, spaced so 100-foot extension cord can reach each area for power hand tools and task lighting. Provide a separate 125-V ac, 20-A circuit for each outlet.

- I. Lighting: Provide temporary lighting with local switching that provides adequate illumination for construction operations and traffic conditions.
 - 1. Install and operate temporary lighting that fulfills security and protection requirements without operating entire system.

- J. Telephone Service: Provide temporary telephone service throughout construction period for common-use facilities used by all personnel engaged in construction activities.

3.03 SUPPORT FACILITIES INSTALLATION

- A. Traffic Controls: Provide temporary traffic controls at junction of temporary roads with public roads. Include warning signs for public traffic and "STOP" signs for entrance onto public roads. Comply with requirements of authorities having jurisdiction.

- B. Street Cleaning: Provide regular street cleaning during course of construction for public streets subject to construction dirt and debris.

- C. Dewatering Facilities and Drains: Comply with requirements in applicable Division 2 Sections for temporary drainage and dewatering facilities and operations not directly associated with construction activities included in individual Sections. Where feasible, use same facilities. Maintain Project site, excavations, and construction free of water.
 - 1. Dispose of rainwater in a lawful manner that will not result in flooding Project or adjoining property nor endanger permanent Work or temporary facilities.
 - 2. Before connection and operation of permanent drainage piping system, provide temporary drainage where roofing or similar waterproof deck construction is completed.
 - 3. Remove snow and ice as required to minimize accumulations.

- D. Waste Disposal Facilities: Provide waste-collection containers in sizes adequate to handle waste from construction operations. Containerize and clearly label hazardous, dangerous, or unsanitary waste materials separately from other waste.
 - 1. If required by authorities having jurisdiction, provide separate containers, clearly labeled, for each type of waste material to be deposited.

- E. Janitorial Services: Provide janitorial services on a daily basis for temporary offices, first-aid stations, toilets, wash facilities, lunchrooms, and similar areas.

SECTION 01 5000 – TEMPORARY FACILITIES AND CONTROLS

- F. Common-Use Field Office: Provide an insulated, weather tight, air-conditioned field office for use as a common facility by all personnel engaged in construction activities; of sufficient size to accommodate required office personnel and meetings of 10 persons at Project site. Keep office clean and orderly.
- G. Storage and Fabrication Sheds: Provide sheds sized, furnished, and equipped to accommodate materials and equipment involved, including temporary utility services. Sheds may be open shelters or fully enclosed spaces within building or elsewhere on-site.
- H. Lifts and Hoists: Provide facilities for hoisting materials and personnel. Truck cranes and similar devices used for hoisting materials are considered "tools and equipment" and not temporary facilities.
- I. Temporary Stairs: Until permanent stairs are available, provide temporary stairs where ladders are not adequate. Cover finished permanent stairs with protective covering of plywood or similar material so finishes will be undamaged at time of acceptance.
- J. Site Enclosure Fence: Before construction operations begin, install chain-link enclosure fence with lockable entrance gates. Locate where indicated, or if not indicated, enclose entire Project site or portion determined sufficient to accommodate construction operations. Install in a manner that will prevent people, dogs, and other animals from easily entering site except by entrance gates.
 - 1. Set fence posts in compacted mixture of gravel and earth.
- K. Security Enclosure and Lockup: Install substantial temporary enclosure around partially completed areas of construction. Provide lockable entrances to prevent unauthorized entrance, vandalism, theft, and similar violations of security.
- L. Temporary Fire Protection: Until fire-protection needs are supplied by permanent facilities, install and maintain temporary fire-protection facilities of types needed to protect against reasonably predictable and controllable fire losses. Comply with NFPA 241.
 - 1. Provide fire extinguishers, installed on walls on mounting brackets, visible and accessible from space being served, with sign mounted above.
 - a. Field Offices: Class A stored-pressure water-type extinguishers.
 - b. Other Locations: Class ABC dry-chemical extinguishers or a combination of extinguishers of NFPA-recommended classes for exposures.
 - c. Locate fire extinguishers where convenient and effective for their intended purpose; provide not less than one extinguisher on each floor at or near each usable stairwell.
 - 2. Provide temporary standpipes and hoses for fire protection. Hang hoses with a warning sign stating that hoses are for fire-protection purposes only and are not to be removed. Match hose size with outlet size and equip with suitable nozzles.

3.04 OPERATION, TERMINATION, AND REMOVAL

- A. Maintenance: Maintain facilities in good operating condition until removal. Protect from damage caused by freezing temperatures and similar elements.

SECTION 01 5000 – TEMPORARY FACILITIES AND CONTROLS

- B. Operation: Enforce strict discipline in use of temporary facilities. Limit availability to intended use to minimize abuse. Maintain facilities in good operating condition until removal. Protect from damage by freezing temperatures and the elements.
- C. Temporary Facility Changeover: Except for using permanent fire protection as soon as available, do not change over from using temporary security and protection facilities to permanent facilities until Substantial Completion without written consent of Owner.
- D. Termination and Removal: Remove each temporary facility when need for its service has ended, when it has been replaced by authorized use of a permanent facility, or no later than Substantial Completion. Complete or, if necessary, restore permanent construction that may have been delayed because of interference with temporary facility.
 - 1. Materials and facilities that constitute temporary facilities are the property of Contractor except for Project identification signs.
 - 2. Remove temporary paving not intended for or acceptable for integration into permanent paving. Where area is intended for landscape development, remove soil and aggregate fill that do not comply with requirements for fill or subsoil. Remove materials contaminated with road oil, asphalt and other petrochemical compounds, and other substances that might impair growth of plant materials or lawns. Repair or replace street paving, curbs, and sidewalks at temporary entrances, as required by authorities having jurisdiction.
 - 3. At Substantial Completion, clean and renovate permanent facilities used during construction period.

3.05 REPAIR OF DAMAGED AREAS

- A. All landscaping, driveways and parking lot areas, etc., which have been occupied and/or damaged by construction operations or material storage, shall be repaired and restored to their original condition to the approval of the Owner's Project Manager before Substantial Completion will be issued.

END OF SECTION 01 5000

SECTION 017300 - EXECUTION

PART 1 - GENERAL

1.1 SUMMARY

- A. Section includes general administrative and procedural requirements governing execution of the Work, including, but not limited to, the following:
 - 1. Construction layout.
 - 2. Installation.
 - 3. Cutting and patching.
 - 4. Coordination of Owner's portion of the Work.
 - 5. Progress cleaning.
 - 6. Starting and adjusting.
 - 7. Protection of installed construction.
 - 8. Correction of the Work.

- B. Related Requirements:
 - 1. Section 017700 "Closeout Procedures" for submitting final property survey with Project Record Documents, recording of Owner-accepted deviations from indicated lines and levels, replacing defective work, and final cleaning.
 - 2. Section 024119 "Selective Demolition" for demolition and removal of selected portions of the building.
 - 3. Section 078413 "Penetration Firestopping" for patching penetrations in fire-rated construction.

1.2 DEFINITIONS

- A. Cutting: Removal of in-place construction necessary to permit installation or performance of subsequent work.

- B. Patching: Fitting and repair work required to restore construction to original conditions after installation of subsequent work.

1.3 PREINSTALLATION MEETINGS

- A. Cutting and Patching Conference: Conduct conference at Project site.
 - 1. Prior to commencing work requiring cutting and patching, review extent of cutting and patching anticipated and examine procedures for ensuring satisfactory result from cutting and patching work. Inform Owner of scheduled meeting. Require representatives of each entity directly concerned with cutting and patching to attend, including the following:
 - a. Contractor's superintendent.
 - b. Trade supervisor responsible for cutting operations.
 - c. Trade supervisor(s) responsible for patching of each type of substrate.

- d. Mechanical, electrical, and utilities subcontractors' supervisors, to the extent each trade is affected by cutting and patching operations.
2. Review areas of potential interference and conflict. Coordinate procedures and resolve potential conflicts before proceeding.
- B. Layout Conference: Conduct conference at Project site.
 1. Review meanings and intent of dimensions, notes, terms, graphic symbols, and other layout information indicated on the Drawings.
 2. Review requirements for including layouts on Shop Drawings and other submittals.
 3. Review areas of potential interference and conflict. Coordinate procedures and resolve potential conflicts before proceeding.

1.4 QUALITY ASSURANCE

- A. Cutting and Patching: Comply with requirements for and limitations on cutting and patching of construction elements.
 1. Structural Elements: When cutting and patching structural elements, or when encountering the need for cutting and patching of elements whose structural function is not known, notify Architect of locations and details of cutting and await directions from Architect before proceeding. Shore, brace, and support structural elements during cutting and patching. Do not cut and patch structural elements in a manner that could change their load-carrying capacity or increase deflection.
 2. Operational Elements: Do not cut and patch operating elements and related components in a manner that results in reducing their capacity to perform as intended or that results in increased maintenance or decreased operational life or safety. Operational elements include the following:
 - a. Primary operational systems and equipment.
 - b. Fire separation assemblies.
 - c. Air or smoke barriers.
 - d. Fire-suppression systems.
 - e. Plumbing piping systems.
 - f. Mechanical systems piping and ducts.
 - g. Control systems.
 - h. Communication systems.
 - i. Fire-detection and -alarm systems.
 - j. Conveying systems.
 - k. Electrical wiring systems.
 - l. Operating systems of special construction.
 3. Other Construction Elements: Do not cut and patch other construction elements or components in a manner that could change their load-carrying capacity, that results in reducing their capacity to perform as intended, or that results in increased maintenance or decreased operational life or safety. Other construction elements include but are not limited to the following:
 - a. Water, moisture, or vapor barriers.
 - b. Membranes and flashings.
 - c. Exterior curtain-wall construction.

- d. Sprayed fire-resistive material.
 - e. Equipment supports.
 - f. Piping, ductwork, vessels, and equipment.
 - g. Noise- and vibration-control elements and systems.
4. Visual Elements: Do not cut and patch construction in a manner that results in visual evidence of cutting and patching. Do not cut and patch exposed construction in a manner that would, in Owner's opinion, reduce the building's aesthetic qualities. Remove and replace construction that has been cut and patched in a visually unsatisfactory manner.
- B. Manufacturer's Installation Instructions: Obtain and maintain on-site manufacturer's written recommendations and instructions for installation of specified products and equipment.

PART 2 - PRODUCTS

2.1 MATERIALS

- A. Comply with requirements specified in other Sections.
- B. In-Place Materials: Use materials for patching identical to in-place materials. For exposed surfaces, use materials that visually match in-place adjacent surfaces to the fullest extent possible.
- 1. If identical materials are unavailable or cannot be used, use materials that, when installed, will provide a match acceptable to Owner for the visual and functional performance of in-place materials. Use materials that are not considered hazardous.
- C. Cleaning Agents: Use cleaning materials and agents recommended by manufacturer or fabricator of the surface to be cleaned. Do not use cleaning agents that are potentially hazardous to health or property or that might damage finished surfaces.

PART 3 - EXECUTION

3.1 EXAMINATION

- A. Existing Conditions: The existence and location of underground and other utilities and construction indicated as existing are not guaranteed. Before beginning sitework, investigate and verify the existence and location of underground utilities, mechanical and electrical systems, and other construction affecting the Work.
- 1. Before construction, verify the location and invert elevation at points of connection of sanitary sewer, storm sewer, gas service piping, and water-service piping; underground electrical services; and other utilities.
 - 2. Furnish location data for work related to Project that must be performed by public utilities serving Project site.
- B. Examination and Acceptance of Conditions: Before proceeding with each component of the Work, examine substrates, areas, and conditions, with Installer or Applicator present where

indicated, for compliance with requirements for installation tolerances and other conditions affecting performance. Record observations.

1. Examine roughing-in for mechanical and electrical systems to verify actual locations of connections before equipment and fixture installation.
 2. Examine walls, floors, and roofs for suitable conditions where products and systems are to be installed.
 3. Verify compatibility with and suitability of substrates, including compatibility with existing finishes or primers.
- C. Written Report: Where a written report listing conditions detrimental to performance of the Work is required by other Sections, include the following:
1. Description of the Work, including Specification Section number and paragraph, and Drawing sheet number and detail, where applicable.
 2. List of detrimental conditions, including substrates.
 3. List of unacceptable installation tolerances.
 4. Recommended corrections.
- D. Proceed with installation only after unsatisfactory conditions have been corrected. Proceeding with the Work indicates acceptance of surfaces and conditions.

3.2 PREPARATION

- A. Existing Utility Information: Furnish information to Owner that is necessary to adjust, move, or relocate existing utility structures, utility poles, lines, services, or other utility appurtenances located in or affected by construction. Coordinate with authorities having jurisdiction.
- B. Field Measurements: Take field measurements as required to fit the Work properly. Recheck measurements before installing each product. Where portions of the Work are indicated to fit to other construction, verify dimensions of other construction by field measurements before fabrication. Coordinate fabrication schedule with construction progress to avoid delaying the Work.
- C. ion. Coordinate fabrication schedule with construction progress to avoid delaying the Work.
- D. Space Requirements: Verify space requirements and dimensions of items shown diagrammatically on Drawings.
- E. Review of Contract Documents and Field Conditions: Immediately on discovery of the need for clarification of the Contract Documents, submit a request for information to Architect in accordance with requirements in Section 013100 "Project Management and Coordination."

3.3 CONSTRUCTION LAYOUT

- A. Verification: Before proceeding to lay out the Work, verify layout information shown on Drawings, in relation to the property survey and existing benchmarks and existing conditions. If discrepancies are discovered, notify Architect promptly.
- B. Record Log: Maintain a log of layout control work. Record deviations from required lines and levels. Include beginning and ending dates and times of surveys, , name and duty of each

survey party member, and types of instruments and tapes used. Make the log available for reference by Owner.

3.4 INSTALLATION

- A. Locate the Work and components of the Work accurately, in correct alignment and elevation, as indicated.
 - 1. Make vertical work plumb and make horizontal work level.
 - 2. Where space is limited, install components to maximize space available for maintenance and ease of removal for replacement.
 - 3. Conceal pipes, ducts, and wiring in finished areas unless otherwise indicated.
 - 4. Maintain minimum headroom clearance of 96 inches (2440 mm) in occupied spaces and 90 inches (2300 mm) in unoccupied spaces, unless otherwise indicated on Drawings. If installation does not allow minimum headroom clearance above, submit RFI to Architect for review.
- B. Comply with manufacturer's written instructions and recommendations for installing products in applications indicated.
- C. Install products at the time and under conditions that will ensure satisfactory results as judged by Architect. Maintain conditions required for product performance until Substantial Completion.
- D. Conduct construction operations, so no part of the Work is subjected to damaging operations or loading in excess of that expected during normal conditions of occupancy of type expected for Project.
- E. Sequence the Work and allow adequate clearances to accommodate movement of construction items on-site and placement in permanent locations.
- F. Tools and Equipment: Select tools or equipment that minimize production of excessive noise levels.
- G. Templates: Obtain and distribute to the parties involved templates for Work specified to be factory prepared and field installed. Check Shop Drawings of other portions of the Work to confirm that adequate provisions are made for locating and installing products to comply with indicated requirements.
- H. Attachment: Provide blocking and attachment plates and anchors and fasteners of adequate size and number to securely anchor each component in place, accurately located and aligned with other portions of the Work. Where size and type of attachments are not indicated, verify size and type required for load conditions with manufacturer.
- I. . Where size and type of attachments are not indicated, verify size and type required for load conditions with manufacturer.
 - 1. Mounting Heights: Where mounting heights are not indicated, mount components at heights directed by Architect.
 - 2. Allow for building movement, including thermal expansion and contraction.
 - 3. Coordinate installation of anchorages. Furnish setting drawings, templates, and directions for installing anchorages, including sleeves, concrete inserts, anchor bolts, and items with

integral anchors, that are to be embedded in concrete or masonry. Deliver such items to Project site in time for installation.

- J. Joints: Make joints of uniform width. Where joint locations in exposed Work are not indicated, arrange joints for the best visual effect, as judged by Architect. Fit exposed connections together to form hairline joints.
- K. m hairline joints.

3.5 CUTTING AND PATCHING

- A. General: Employ skilled workers to perform cutting and patching. Proceed with cutting and patching at the earliest feasible time, and complete without delay.
 - 1. Cut in-place construction to provide for installation of other components or performance of other construction, and subsequently patch as required to restore surfaces to their original condition.
- B. Existing Warranties: Remove, replace, patch, and repair materials and surfaces cut or damaged during installation or cutting and patching operations, by methods and with materials so as not to void existing warranties.
- C. Temporary Support: Provide temporary support of Work to be cut.
- D. Protection: Protect in-place construction during cutting and patching to prevent damage. Provide protection from adverse weather conditions for portions of Project that might be exposed during cutting and patching operations.
- E. Adjacent Occupied Areas: Where interference with use of adjoining areas or interruption of free passage to adjoining areas is unavoidable, coordinate cutting and patching in accordance with requirements in Section 011000 "Summary."
- F. Existing Utility Services and Mechanical/Electrical Systems: Where existing services/systems are required to be removed, relocated, or abandoned, bypass such services/systems before cutting to minimize interruption to occupied areas. Review impact of work with Owner prior to commencement for coordination with building occupants.
- G. Cutting: Cut in-place construction by sawing, drilling, breaking, chipping, grinding, and similar operations, including excavation, using methods least likely to damage elements retained or adjoining construction. If possible, review proposed procedures with original Installer; comply with original Installer's written recommendations.
 - 1. In general, use hand or small power tools designed for sawing and grinding, not hammering and chopping. Cut holes and slots neatly to minimum size required, and with minimum disturbance of adjacent surfaces. Temporarily cover openings when not in use.
 - 2. isturbance of adjacent surfaces. Temporarily cover openings when not in use.
 - 3. Finished Surfaces: Cut or drill from the exposed or finished side into concealed surfaces.
 - 4. Concrete and Masonry: Cut using a cutting machine, such as an abrasive saw or a diamond-core drill.
 - 5. Excavating and Backfilling: Comply with requirements in applicable Sections where required by cutting and patching operations.

6. Mechanical and Electrical Services: Cut off pipe or conduit in walls or partitions to be removed. Cap, valve, or plug and seal remaining portion of pipe or conduit to prevent entrance of moisture or other foreign matter after cutting.
 7. Proceed with patching after construction operations requiring cutting are complete.
- H. Patching: Patch construction by filling, repairing, refinishing, closing up, and similar operations following performance of other Work. Patch with durable seams that are as invisible as practicable, as judged by Architect. Provide materials and comply with installation requirements specified in other Sections, where applicable.
1. Inspection: Where feasible, test and inspect patched areas after completion to demonstrate physical integrity of installation.
 2. Exposed Finishes: Restore exposed finishes of patched areas and extend finish restoration into retained adjoining construction in a manner that will eliminate evidence of patching and refinishing.
 - a. Clean piping, conduit, and similar features before applying paint or other finishing materials.
 - b. Restore damaged pipe covering to its original condition.
 3. Floors and Walls: Where walls or partitions that are removed extend one finished area into another, patch and repair floor and wall surfaces in the new space. Provide an even surface of uniform finish, color, texture, and appearance. Remove in-place floor and wall coverings and replace with new materials, if necessary, to achieve uniform color and appearance.
 - a. Where patching occurs in a painted surface, prepare substrate and apply primer and intermediate paint coats appropriate for substrate over the patch, and apply final paint coat over entire unbroken surface containing the patch, corner to corner of wall and edge to edge of ceiling. Provide additional coats until patch blends with adjacent surfaces.
 - b. and apply final paint coat over entire unbroken surface containing the patch, corner to corner of wall and edge to edge of ceiling. Provide additional coats until patch blends with adjacent surfaces.
 4. Ceilings: Patch, repair, or rehang in-place ceilings as necessary to provide an even-plane surface of uniform appearance.
 5. Exterior Building Enclosure: Patch components in a manner that restores enclosure to a weathertight condition and ensures thermal and moisture integrity of building enclosure.
- I. Cleaning: Clean areas and spaces where cutting and patching are performed. Remove paint, mortar, oils, putty, and similar materials from adjacent finished surfaces.
- 3.6 COORDINATION OF OWNER'S PORTION OF THE WORK
- A. Site Access: Provide access to Project site for Owner's construction personnel.
1. Refer to Section 011000 "Summary" for other requirements for Owner-furnished, Contractor-installed and Owner-furnished, Owner-installed products.

- B. Coordination: Coordinate construction and operations of the Work with work performed by Owner's construction personnel.
 - 1. Construction Schedule: Inform Owner of Contractor's preferred construction schedule for Owner's portion of the Work. Adjust construction schedule based on a mutually agreeable timetable. Notify Owner if changes to schedule are required due to differences in actual construction progress.
 - 2. Preinstallation Conferences: Include Owner's construction personnel at preinstallation conferences covering portions of the Work that are to receive Owner's work. Attend preinstallation conferences conducted by Owner's construction personnel if portions of the Work depend on Owner's construction.

3.7 PROGRESS CLEANING

- A. Clean Project site and work areas daily, including common areas. Enforce requirements strictly. Dispose of materials lawfully.
 - 1. Comply with requirements in NFPA 241 for removal of combustible waste materials and debris.
 - 2. Do not hold waste materials more than seven days during normal weather or three days if the temperature is expected to rise above 80 deg F (27 deg C).
 - 3. Containerize hazardous and unsanitary waste materials separately from other waste. Mark containers appropriately and dispose of legally, in accordance with regulations.
 - a. Use containers intended for holding waste materials of type to be stored.
 - 4. Coordinate progress cleaning for joint-use areas where Contractor and other contractors are working concurrently.
- B. Site: Maintain Project site free of waste materials and debris.
- C. Work Areas: Clean areas where Work is in progress to the level of cleanliness necessary for proper execution of the Work.
 - 1. Remove liquid spills promptly.
 - 2. Where dust would impair proper execution of the Work, broom-clean or vacuum the entire work area, as appropriate.
- D. Work area is to be negatively pressured relative to adjacent spaces to reduce migration of dust and debris outside project scope area.
- E. Installed Work: Keep installed work clean. Clean installed surfaces in accordance with written instructions of manufacturer or fabricator of product installed, using only cleaning materials specifically recommended. If specific cleaning materials are not recommended, use cleaning materials that are not hazardous to health or property and that will not damage exposed surfaces.
- F. Concealed Spaces: Remove debris from concealed spaces before enclosing the space.
- G. Exposed Surfaces: Clean exposed surfaces and protect as necessary to ensure freedom from damage and deterioration at time of Substantial Completion.

- H. Waste Disposal: Do not bury or burn waste materials on-site. Do not wash waste materials down sewers or into waterways. Comply with waste disposal requirements in Section 015000 "Temporary Facilities and Controls."
- I. During handling and installation, clean and protect construction in progress and adjoining materials already in place. Apply protective covering where required to ensure protection from damage or deterioration at Substantial Completion.
- J. Clean and provide maintenance on completed construction as frequently as necessary through the remainder of the construction period. Adjust and lubricate operable components to ensure operability without damaging effects.
- K. Limiting Exposures: Supervise construction operations to ensure that no part of the construction, completed or in progress, is subject to harmful, dangerous, damaging, or otherwise deleterious exposure during the construction period.

3.8 STARTING AND ADJUSTING

- A. Coordinate startup and adjusting of equipment and operating components with requirements in Section 019113 "General Commissioning Requirements."
- B. Start equipment and operating components to confirm proper operation. Remove malfunctioning units, replace with new units, and retest.
- C. Adjust equipment for proper operation. Adjust operating components for proper operation without binding.
- D. Test each piece of equipment to verify proper operation. Test and adjust controls and safeties. Replace damaged and malfunctioning controls and equipment.
- E. Manufacturer's Field Service: Comply with qualification requirements in Section 014000 "Quality Requirements."

3.9 PROTECTION OF INSTALLED CONSTRUCTION

- A. Provide final protection and maintain conditions that ensure installed Work is without damage or deterioration at time of Substantial Completion.
- B. Protection of Existing Items: Provide protection and ensure that existing items to remain undisturbed by construction are maintained in condition that existed at commencement of the Work.
- C. Comply with manufacturer's written instructions for temperature and relative humidity.

3.10 CORRECTION OF THE WORK

- A. Repair or remove and replace damaged, defective, or nonconforming Work. Restore damaged substrates and finishes.

1. Repairing includes replacing defective parts, refinishing damaged surfaces, touching up with matching materials, and properly adjusting operating equipment.
- B. Repair Work previously completed and subsequently damaged during construction period. Repair to like-new condition.
- C. Restore permanent facilities used during construction to their specified condition.
- D. Remove and replace damaged surfaces that are exposed to view if surfaces cannot be repaired without visible evidence of repair.
- E. Repair components that do not operate properly. Remove and replace operating components that cannot be repaired.
- F. Remove and replace chipped, scratched, and broken glass or reflective surfaces.

END OF SECTION 017300

SECTION 01 7700 – CONTRACT CLOSE-OUT

SECTION 01 7700 - CONTRACT CLOSE-OUT

PART 1 – GENERAL

1.01 SUMMARY

- A. This Section specifies administrative and procedural requirements for project closeout, including but not limited to:
 - 1. Inspection procedures for Substantial Completion and Final Completion.
 - 2. Project record document submittal.
 - 3. Operating and maintenance manual submittal.
 - 4. Submittal of warranties.
 - 5. Final cleaning.
 - 6. Post Construction Review Meeting.

- B. Closeout requirements for specific construction activities are included in the appropriate Sections in Divisions 2 through 45.

1.02 SUBSTANTIAL COMPLETION:

- A. Preliminary Procedures: Before requesting an inspection for certification of Substantial Completion (for either entire Work or portions thereof), complete the following. List exceptions in the request.
 - 1. Submit written notice that the project is substantially complete to the Architect and Owner. Provide a list of items not yet in conformance with the contract documents which require attention.
 - 2. Submit one (1) electronic copy of the Operation and Maintenance Manuals to the Architect through Procore.
 - 3. Submit Record Drawings to the Architect through Procore. If only a portion of the work is substantially complete, submit a copy of the Record Drawings covering the completed work.
 - 4. Submit specific warranties, workmanship bonds, maintenance agreements, final certifications, and similar documents to the Architect.
 - 5. Obtain and submit releases enabling the Owner unrestricted use of the Work and access to services and utilities; operating certificates, and similar releases.
 - 6. Deliver tools, spare parts, extra stock, and similar items with appropriate transmittal to the Owner.
 - 7. Complete start-up testing of systems, and instruction of the Owner's operating and maintenance personnel. Discontinue or change over and remove temporary facilities from the site, along with construction tolls, mock-ups, and similar elements.
 - 8. Complete final clean up requirements, including touch-up painting.

SECTION 01 7700 – CONTRACT CLOSE-OUT

- B. Inspection Procedures: Upon receipt of a request for inspection, the Architect will either proceed with inspection or advise the Contractor on unfilled requirements. Following inspection, the Architect will advise the Contractor of construction that must be completed or corrected before the certificate will be issued.
1. The Architect will repeat inspection when requested and assured that the Work has been substantially completed.
 2. Results of the completed inspection will form the basis of requirements for final completion.
- C. Issuance of Certificate:
1. Upon a satisfactory inspection and Contractor completion of the items of substantial completion, the Architect will issue Certificate of Substantial Completion and forward to Contractor.

1.03 FINAL COMPLETION:

- A. Preliminary Procedures: Before requesting final inspection for the certification of final Completion and final billing, complete the following. List exceptions in the request.
1. Submit "Consent of Surety to Final Payment." This consent shall be completed by the Surety and mailed to the University.
 2. Submit final billing request with final releases and supporting documentation not previously submitted or accepted to Owner.
 3. Submit a signed copy of the Architect's final inspection list of items to be completed or corrected, stating that each item has been completed or otherwise resolved for completion to the Architect.
 4. Deliver tools, spare parts, extra stock of materials, and similar physical items to the Owner.
 5. Return loaned construction keys to Purdue University Lock Shop, and advise Owner's personnel of change-over in security provisions.
 6. Complete start-up testing of systems, and instruction of Owner's Operating/maintenance personnel. Discontinue or change-over and remove from project site temporary facilities and services, along with construction tools and facilities, mock-ups, and similar elements.
 7. Complete final cleaning requirements, including touch-up of marred surfaces. Touch-up, repair, and restore marred exposed finishes.
- B. Reinspection Procedure: The Architect will reinspect the Work upon receipt of notice that the Work, including inspection list items from earlier inspections, has been completed, except items whose completion has been delayed because of circumstances acceptable to the Architect.
1. Upon completion of reinspection, the Architect will prepare a certificate of final completion, or advise the Contractor of Work that is incomplete or of obligations that have not been fulfilled but are required for final completion.
 2. If necessary, reinspection will be repeated.

SECTION 01 7700 – CONTRACT CLOSE-OUT

1.04 REINSPECTION FEES

- A. Should the Architect be required to perform reinspections due to failure of the work to comply with the status of completion claimed by the Contractor, Owner will:
 - 1. compensate the Architect for such additional or "extra" services; and
 - 2. deduct the amount of such compensation from the final payment to the Contractor.

1.05 RECORD DOCUMENT SUBMITTALS:

- A. General: Do not use record documents for construction purposes; protect from deterioration and loss in a secure location; provide access to record documents for the Architect's reference during normal working hours.
- B. The Contractor shall update the Record Documents regularly, and in no event less than once per week. As part of the weekly project meeting, the Contractor shall inform the Project Manager of the status of the updating of Record Documents and, if requested by the Project Manager or Architect, demonstrate that the Record Documents have been recently updated to show current conditions. Failure on the part of the Contractor to update the Record Documents as provided herein shall be cause for withholding a portion of monthly payment until such failure is corrected.
- C. Do not permanently conceal any work until required information has been recorded.
- D. Record Drawings ("As-Builts"): Maintain a clean, undamaged set of blue or black line prints of Contract Drawings, Shop Drawings, and Coordination Drawings. Mark the set to show the actual installation where the installation varies substantially from the Work as originally shown. Mark whichever drawing is the most capable of showing conditions fully and accurately; where Shop Drawings or Coordination Drawings are used, record a cross-reference at the corresponding location on the Contract Drawings. Give particular attention to concealed elements that would be difficult to measure and record at a later date. Submit record drawings at Substantial Completion to the Architect.
 - 1. Mark record sets with red erasable pencil; use other colors to distinguish between variations in separate categories of the Work.
 - 2. Mark new information that is important to the Owner, but was not shown on Contract Drawings, Shop Drawings, or Coordination Drawings.
 - 3. Note related Request for Information (RFI) numbers and Change Order numbers where applicable.
 - 4. Keep accurate measurements of underground services and utilities referenced to the building or other permanent construction.
 - 5. Note changes of directions and locations, by dimensions and elevations, as utilities are actually installed. Show mechanical dampers, valves, reheat boxes, cleanouts, and other items that require maintenance.
 - 6. Show location of construction-concealed internal utilities and appurtenances referenced to visible and accessible features of the structure.

SECTION 01 7700 – CONTRACT CLOSE-OUT

- 7. Record accurate locations of piping, valves, traps, dampers, duct work, equipment, and the like.
 - 8. Indicate field changes of dimension and detail.
 - 9. "X-out" and appropriately annotate "not constructed" - whichever condition most clearly conveys the actual "as constructed" condition.
 - 10. Show addenda items.
 - 11. Organize record drawing sheets into bound manageable sets
 - 12. Every page needs a red stamp or label on the lower right hand corner near the title block stating "AS-BUILTS"
- E. Miscellaneous Record Submittals: Refer to other Specification Sections for requirements of miscellaneous record-keeping and submittals in connection with actual performance of the Work. Immediately prior to date or dates of Substantial Completion, complete miscellaneous records and place in good order, properly identified and bound or filed, read with continued use and reference. Submit to the Architect.
- 1.06 OPERATING AND MAINTENANCE MANUALS:
- A. Renovations - Provide one (1) electronic copy through Procore. New Buildings – Provide one (1) electronic copy through Procore and two (2) original hard copies of Maintenance Manual(s). Deliver the preliminary manual to the Architect for review prior to Substantial Completion or starting of major equipment, whichever is sooner. The preliminary copy shall comply with all of these requirements except the covers (although the intended layout for same shall be provided). Deliver final manuals and PDF files to Architect for final review. Architect to forward final sets prior to final completion to Owner.
 - B. General Construction Work:
 - 1. All materials and equipment will be listed by corresponding specification section.
 - 2. Final paint and color schedule, manufacturer of paint used, number, location, matching Sherwin Williams paint formula or number; final carpet selection and color, locations; final plastic laminate selections and color, locations; and all other finishes. Recommended maintenance and cleaning procedures for all exposed interior and exterior materials.
 - 3. Copies of Warranties and Guaranties, with names of servicing agencies.
 - a. All executed certificates, warranties, bonds, and any required service and maintenance contracts from the respective manufacturers, suppliers, and subcontractors.
 - b. Provide complete information for each of the following:
 - i. Product or work item;
 - ii. Firm, with name of principal, address, and telephone number;
 - iii. Scope;
 - iv. Substantial Completion Letter;
 - v. Date of beginning of warranty or service and maintenance contract (unless approved otherwise, the warranty begins on the date of Substantial Completion);

SECTION 01 7700 – CONTRACT CLOSE-OUT

- vi. Duration of warranty or service maintenance contract;
 - vii. Proper procedure in case of failure;
 - viii. Insurances which might affect validity of warranty or bond;
 - ix. Contractor's name or responsible principal, address, and telephone number.
 - 4. Emergency Instructions.
 - 5. Spare parts list.
 - 6. Recommended "turn around" cycles of equipment, maintenance, and surface treatments or finishes.
 - 7. Shop drawings and product data of actual installed items.
 - 8. Original warranties – to be submitted under separate cover.
 - 9. General custodial cleaning instructions for interior finish materials utilized.
- C. Work of Divisions 21, 22, & 23 (Mechanical) and Divisions 25, 26, 27, & 28 (Electrical):
- 1. Copies of approved equipment submittals including equipment manufacturer, make, model number, size, unique equipment ID, serial number, installed location, etc.
 - 2. Supplier's name, address, phone, and reference order numbers.
 - 3. Equipment nameplate and data of major items.
 - 4. Description of system configuration and operation including component identification and interrelations. A master control schematic drawing(s) will normally be required for this purpose.
 - 5. Dimensional and performance data for specific unit provided. Extraneous catalog data must be eliminated.
 - 6. Manufacturers' recommended operation instructions as appropriate.
 - 7. Manufacturers' recommended lubrication and servicing data.
 - 8. Complete parts list including recording information, recommended spares, and anticipated useful life.
 - 9. Fan and pump curves.
 - 10. Fixture lamping schedule.
 - 11. Wiring diagrams.
 - 12. Inspection Procedures.
 - 13. Recommended "tum around" cycles of all equipment and maintenance.
 - 14. Single-Line Diagrams, Flow Diagrams of systems.
 - 15. Final Testing and Balancing Report – to be submitted under separate cover.
 - 16. As-built sequences of operations, control drawings, and original set points.
 - 17. Recommended schedule of calibrating sensors and actuators.
- D. Binders:
- 1. Copies shall be properly indexed and three-hole punched in locking three-ring binders. Provide pocket folders for folded sheet information.
 - 2. Imprint covers with "OPERATING AND MAINTENANCE MANUAL," "PROJECT TITLE," "Purdue University," Prime Architect/Engineer, and Prime General Contractor, and year of completion.

SECTION 01 7700 – CONTRACT CLOSE-OUT

3. Imprint the back edge with "OPERATING AND MAINTENANCE MANUAL," "PROJECT TITLE," and the year of completion.
4. Each copy shall have a type written index and tabbed dividers between categories or sections.
5. Each copy or volume of manual shall not exceed 3-1/2 inch width when three inch binders are used. Label volumes successively by volume # (Ex. Vol. 1 of 3).
6. Each Volume will contain a Table of Contents and Tabs 1-3 noted below.
7. These manuals shall contain all the information needed to operate and maintain all systems and equipment provided in the project. Present and arrange logically for efficient use by the Owner's operating personnel As a minimum the information provided shall include the following:
 - a. Table of Contents
 - b. Tab 1 – Substantial Completion Letter
 - c. Tab 2 – Contact list and corresponding scope of work containing phone, fax, email, and address of the prime contractor, subcontractors, and major manufacturers.
 - d. Tab 3 – Prime contractor's 1 yr. standard warranty on labor and material.
 - e. Remaining tabs contain CSI Divisions 2-45

1.07 CORRECTION OF WORK DURING GUARANTEE PERIOD

- A. Corrections: Where items on the Architect's "Punch List" have not been corrected prior to expiration of the specified guarantee period, it shall nevertheless be the responsibility of the Contractor to permanently correct said items after the specified guarantee period, and the contract corrections are made.
- B. Guarantee Period: All corrective work performed by the Contractor, in remedying defective work during the guarantee period following the Owner's acceptance of the project, shall be subject to the same guarantee requirements of the original work for a period as specified from the date of completion of the corrective work.

PART 2-PRODUCTS - NOT APPLICABLE

PART 3-EXECUTION

3.01 SYSTEMS DEMONSTRATIONS:

- A. Operating and Maintenance Instructions:
 1. After substantial completion and prior to final inspection or full acceptance of the Project, Contractor shall provide qualified personnel for conducting full operation and maintenance training and instructions in the operation, adjustment and maintenance of all operating equipment and systems to Owner's designated personnel; include all general, mechanical and electrical operating systems and equipment.

SECTION 01 7700 – CONTRACT CLOSE-OUT

2. Except as otherwise specified, arrange for each installer of work requiring continuing maintenance or operation to meet with Owner's personnel, at project site, to provide basic instructions needed for proper operation and maintenance of entire work. Include instructions by manufacturer's representatives where installers are not expert in the required procedures.
 3. If installers are not experienced in procedures (in the opinion of the Architect; submit list of experience for each instructor), provide instruction by manufacturer's representatives.
- B. Use operating and maintenance manuals as the basis for instruction. Review contents of Manual with personnel in full detail to explain all aspect of operations and maintenance to include but not limited to:
1. Maintenance Manuals.
 2. Record documents.
 3. Spare parts and materials.
 4. Tools.
 5. Lubricants.
 6. Fuels.
 7. Identification systems.
 8. Control sequences.
 9. Hazards.
 10. Cleaning.
 11. Warranties and bonds.
 12. Maintenance agreements and similar continuing commitments.
- C. As part of instruction for operating equipment, demonstrate the following procedures:
1. Start-up.
 2. Shut down.
 3. Emergency operations.
 4. Noise and vibration adjustments.
 5. Safety procedures.
 6. Economy and efficiency adjustments.
 7. Effective energy utilization.
- D. For additional requirements for operations instruction, see respective Specification Sections.
- 3.02 FINAL CLEANING:
- A. Cleaning: Employ experienced workers or professional cleaners for final cleaning. Clean each surface or unit to the condition expected in a normal, commercial building cleaning and maintenance program. Comply with manufacturer's instructions.
- B. Complete the following cleaning operations before requesting inspection for Certification of Substantial Completion.

SECTION 01 7700 – CONTRACT CLOSE-OUT

1. Remove labels that are not permanent labels.
 2. Do not use razor blades to clean any glazing or mirrors.
 3. Clean transparent materials, including mirrors and glass in doors and windows. Remove glazing compound and other substances that are noticeable vision obscuring materials. Replace chipped or broken glass and other damaged transparent materials.
 4. Clean exposed exterior and interior hard-surfaced finishes to a dust-free condition, free of stains, films, and similar foreign substances. Restore reflective surfaces to their original reflective condition. Leave concrete floors broom clean. Vacuum carpeted surfaces.
 5. Wipe surfaces of mechanical and electrical equipment. Remove excess lubrication and other substances. Clean plumbing fixtures to a sanitary condition. Clean light fixtures and lamps.
 6. Clean the site, including landscape development areas, of rubbish, litter and foreign substances. Sweep paved areas broom clean; remove stains, spills and other foreign deposits. Rake grounds that are neither paved nor planted, to a smooth even-textured surface.
 7. Leave spaces clean enough so that routine "Daily" maintenance will make them ready for occupancy.
- C. Removal of Protection: Remove temporary protection and facilities installed for protection of the Work during construction.
- D. Compliance: Comply with regulations of authorities having jurisdiction and safety standards for cleaning. Do not burn waste materials. Do not bury debris or excess materials on the Owner's property. Do not discharge volatile, harmful, or dangerous materials into drainage systems.
1. Remove waste materials from the site and dispose of in a lawful manner.
 2. Where extra materials of value remaining after completion of associated Work have become the Owner's property, arrange for disposition of these materials as directed.
- 3.03 POST CONSTRUCTION REVIEW MEETING:
- A. This will be a final analysis by the Project Team of the overall Project from Design to Post-Construction. Participants will include but not limited to: Project Manager, Architect/Engineer, General Contractor and prime subcontractors, PM&C Clerical Staff and University Clients.
- B. Items to be discussed include but not limited to the following:
1. Project Communication and Processes
 2. Quality of Meetings
 3. Customer Satisfaction
 4. Product / Service Acceptance

SECTION 01 7700 – CONTRACT CLOSE-OUT

5. Project on Time
6. Project within Budget
7. Architect/ Engineer, Contractor Interactions
8. Management

END OF SECTION 01 7700

SECTION 024119 - SELECTIVE DEMOLITION

PART 1 - GENERAL

1.1 SUMMARY

A. Section Includes:

1. Demolition and removal of selected portions of building or structure.
2. Salvage of existing items to be reused or recycled.

B. Related Requirements:

1. Section 011000 "Summary" for restrictions on use of the premises, Owner-occupancy requirements, and phasing requirements.
2. Section 017300 "Execution" for cutting and patching procedures.

1.2 DEFINITIONS

- A. Remove: Detach items from existing construction and dispose of them off-site unless indicated to be salvaged or reinstalled.
- B. Remove and Salvage: Detach items from existing construction, in a manner to prevent damage, and deliver to Owner ready for reuse or store.
- C. Remove and Reinstall: Detach items from existing construction, in a manner to prevent damage, prepare for reuse, and reinstall where indicated.
- D. Existing to Remain: Leave existing items that are not to be removed and that are not otherwise indicated to be salvaged or reinstalled.
- E. Dismantle: To remove by disassembling or detaching an item from a surface, using gentle methods and equipment to prevent damage to the item and surfaces; disposing of items unless indicated to be salvaged or reinstalled.

1.3 MATERIALS OWNERSHIP

- A. Unless otherwise indicated, demolition waste becomes property of Contractor.

1.4 PREINSTALLATION MEETINGS

- A. Predemolition Conference: Conduct conference at Project site.

1. Inspect and discuss condition of construction to be selectively demolished.
2. Review structural load limitations of existing structure.
3. Review and finalize selective demolition schedule and verify availability of materials, demolition personnel, equipment, and facilities needed to make progress and avoid delays.

4. Review requirements of work performed by other trades that rely on substrates exposed by selective demolition operations.
5. Review areas where existing construction is to remain and requires protection.

1.5 INFORMATIONAL SUBMITTALS

- A. Proposed Protection Measures: Submit report, including Drawings, that indicates the measures proposed for protecting individuals and property, for dust control and, for noise control. Indicate proposed locations and construction of barriers.
- B. Schedule of Selective Demolition Activities: Indicate the following:
 1. Detailed sequence of selective demolition and removal work, with starting and ending dates for each activity. Ensure Owner's and other tenants' on-site operations are uninterrupted.
 2. Interruption of utility services. Indicate how long utility services will be interrupted.
 3. Coordination for shutoff, capping, and continuation of utility services.
 4. Use of elevator and stairs.
 5. Coordination of Owner's continuing occupancy of portions of existing building and of Owner's partial occupancy of completed Work.
- C. Predemolition Photographs or Video: Show existing conditions of adjoining construction, including finish surfaces, that might be misconstrued as damage caused by salvage and demolition operations. Comply with Section 013233 "Photographic Documentation." Submit before Work begins.
- D. Warranties: Documentation indicating that existing warranties are still in effect after completion of selective demolition.

1.6 CLOSEOUT SUBMITTALS

- A. Inventory: Submit a list of items that have been removed and salvaged.

1.7 FIELD CONDITIONS

- A. Owner will occupy portions of building immediately adjacent to selective demolition area. Conduct selective demolition so Owner's operations will not be disrupted.
- B. Conditions existing at time of inspection for bidding purpose will be maintained by Owner as far as practical.
 1. Before selective demolition, Owner will remove the following items:
 - a. Loose furniture and equipment.
- C. Notify Architect of discrepancies between existing conditions and Drawings before proceeding with selective demolition.
- D. Hazardous Materials: It is not expected that hazardous materials will be encountered in the Work.
 1. Hazardous materials will be removed by Owner before start of the Work.

2. If suspected hazardous materials are encountered, do not disturb; immediately notify Architect and Owner. Hazardous materials will be removed by Owner under a separate contract.

E. Storage or sale of removed items or materials on-site is not permitted.

F. Utility Service: Maintain existing utilities indicated to remain in service and protect them against damage during selective demolition operations.

1. Maintain fire-protection facilities in service during selective demolition operations.

1.8 COORDINATION

A. Arrange selective demolition schedule so as not to interfere with Owner's operations.

PART 2 - PRODUCTS

2.1 PERFORMANCE REQUIREMENTS

A. Regulatory Requirements: Comply with governing EPA notification regulations before beginning selective demolition. Comply with hauling and disposal regulations of authorities having jurisdiction.

B. Standards: Comply with ANSI/ASSP A10.6 and NFPA 241.

PART 3 - EXECUTION

3.1 EXAMINATION

A. Verify that utilities have been disconnected and capped before starting selective demolition operations.

B. Review Project Record Documents of existing construction or other existing condition and hazardous material information provided by Owner. Owner does not guarantee that existing conditions are same as those indicated in Project Record Documents.

C. Steel Tendons: Locate tensioned steel tendons and include recommendations for de-tensioning.

D. Verify that hazardous materials have been remediated before proceeding with building demolition operations.

E. Survey of Existing Conditions: Record existing conditions by use of preconstruction photographs or video.

1. Inventory and record the condition of items to be removed and salvaged.

2. Before selective demolition or removal of existing building elements that will be reproduced or duplicated in final Work, make permanent record of measurements, materials, and construction details required to make exact reproduction.

3.2 UTILITY SERVICES AND MECHANICAL/ELECTRICAL SYSTEMS

- A. Existing Services/Systems to Remain: Maintain services/systems indicated to remain and protect them against damage.
- B. Existing Services/Systems to Be Removed, Relocated, or Abandoned: Locate, identify, disconnect, and seal or cap off utility services and mechanical/electrical systems serving areas to be selectively demolished.
 - 1. Owner will arrange to shut off indicated services/systems when requested by Contractor.
 - 2. If services/systems are required to be removed, relocated, or abandoned, provide temporary services/systems that bypass area of selective demolition and that maintain continuity of services/systems to other parts of building.
 - 3. Disconnect, demolish, and remove fire-suppression systems, plumbing, and HVAC systems, equipment, and components indicated on Drawings to be removed.
 - a. Piping to Be Removed: Remove portion of piping indicated to be removed and cap or plug remaining piping with same or compatible piping material.
 - b. Piping to Be Abandoned in Place: Drain piping and cap or plug piping with same or compatible piping material and leave in place.
 - c. Equipment to Be Removed: Disconnect and cap services and remove equipment.
 - d. Equipment to Be Removed and Reinstalled: Disconnect and cap services and remove, clean, and store equipment; when appropriate, reinstall, reconnect, and make equipment operational.
 - e. Equipment to Be Removed and Salvaged: Disconnect and cap services and remove equipment and deliver to Owner.
 - f. Ducts to Be Removed: Remove portion of ducts indicated to be removed and plug remaining ducts with same or compatible ductwork material.
 - g. Ducts to Be Abandoned in Place: Cap or plug ducts with same or compatible ductwork material and leave in place.

3.3 PROTECTION

- A. Temporary Protection: Provide temporary barricades and other protection required to prevent injury to people and damage to adjacent buildings and facilities to remain.
 - 1. Provide protection to ensure safe passage of people around selective demolition area and to and from occupied portions of building.
 - 2. Provide temporary weather protection, during interval between selective demolition of existing construction on exterior surfaces and new construction, to prevent water leakage and damage to structure and interior areas.
 - 3. Protect walls, ceilings, floors, and other existing finish work that are to remain or that are exposed during selective demolition operations.
 - 4. Cover and protect furniture, furnishings, and equipment that have not been removed.
 - 5. Comply with requirements for temporary enclosures, dust control, heating, and cooling specified in Section 015000 "Temporary Facilities and Controls."
- B. Temporary Shoring: Design, provide, and maintain shoring, bracing, and structural supports as required to preserve stability and prevent movement, settlement, or collapse of construction and finishes to remain, and to prevent unexpected or uncontrolled movement or collapse of construction being demolished.
 - 1. Strengthen or add new supports when required during progress of selective demolition.

- C. Remove temporary barricades and protections where hazards no longer exist.

3.4 SELECTIVE DEMOLITION, GENERAL

- A. General: Demolish and remove existing construction only to the extent required by new construction and as indicated. Use methods required to complete the Work within limitations of governing regulations and as follows:

1. Proceed with selective demolition systematically, from higher to lower level. Complete selective demolition operations above each floor or tier before disturbing supporting members on the next lower level.
2. Neatly cut openings and holes plumb, square, and true to dimensions required. Use cutting methods least likely to damage construction to remain or adjoining construction. Use hand tools or small power tools designed for sawing or grinding, not hammering and chopping. Temporarily cover openings to remain.
3. Cut or drill from the exposed or finished side into concealed surfaces to avoid marring existing finished surfaces.
4. Do not use cutting torches until work area is cleared of flammable materials. At concealed spaces, such as duct and pipe interiors, verify condition and contents of hidden space before starting flame-cutting operations. Maintain portable fire-suppression devices during flame-cutting operations.
5. Maintain fire watch during and for at least two-hours after flame-cutting operations.
6. Maintain adequate ventilation when using cutting torches.
7. Remove decayed, vermin-infested, or otherwise dangerous or unsuitable materials and promptly dispose of off-site.
8. Remove structural framing members and lower to ground by method suitable to avoid free fall and to prevent ground impact or dust generation.
9. Locate selective demolition equipment and remove debris and materials so as not to impose excessive loads on supporting walls, floors, or framing.
10. Dispose of demolished items and materials promptly.

- B. Site Access and Temporary Controls: Conduct selective demolition and debris-removal operations to ensure minimum interference with roads, streets, walks, walkways, and other adjacent occupied and used facilities.

- C. Removed and Salvaged Items:

1. Clean salvaged items.
2. Pack or crate items after cleaning. Identify contents of containers.
3. Store items in a secure area until delivery to Owner.
4. Transport items to Owner's storage area designated by Owner.
5. Protect items from damage during transport and storage.

- D. Removed and Reinstalled Items:

1. Clean and repair items to functional condition adequate for intended reuse.
2. Pack or crate items after cleaning and repairing. Identify contents of containers.
3. Protect items from damage during transport and storage.
4. Reinstall items in locations indicated. Comply with installation requirements for new materials and equipment. Provide connections, supports, and miscellaneous materials necessary to make item functional for use indicated.

- E. Existing Items to Remain: Protect construction indicated to remain against damage and soiling during selective demolition. When permitted by Architect, items may be removed to a suitable, protected storage location during selective demolition and cleaned and reinstalled in their original locations after selective demolition operations are complete.

3.5 SELECTIVE DEMOLITION PROCEDURES FOR SPECIFIC MATERIALS

- A. Concrete: Demolish in sections. Cut concrete full depth at junctures with construction to remain and at regular intervals using power-driven saw, and then remove concrete between saw cuts.
- B. Masonry: Demolish in small sections. Cut masonry at junctures with construction to remain, using power-driven saw, and then remove masonry between saw cuts.
- C. Concrete Slabs-on-Grade: Saw-cut perimeter of area to be demolished, and then break up and remove.
- D. Resilient Floor Coverings: Remove floor coverings and adhesive according to recommendations in RFCI's "Recommended Work Practices for the Removal of Resilient Floor Coverings." Do not use methods requiring solvent-based adhesive strippers.

3.6 DISPOSAL OF DEMOLISHED MATERIALS

- A. Remove demolition waste materials from Project site and dispose of them in an EPA-approved construction and demolition waste landfill acceptable to authorities having jurisdiction.
 - 1. Do not allow demolished materials to accumulate on-site.
 - 2. Remove and transport debris in a manner that will prevent spillage on adjacent surfaces and areas.
 - 3. Remove debris from elevated portions of building by chute, hoist, or other device that will convey debris to grade level in a controlled descent.
 - 4. Comply with requirements specified in Section 017419 "Construction Waste Management and Disposal."
- B. Burning: Do not burn demolished materials.

3.7 CLEANING

- A. Clean adjacent structures and improvements of dust, dirt, and debris caused by selective demolition operations. Return adjacent areas to condition existing before selective demolition operations began.

END OF SECTION 024119

SECTION 078413 - PENETRATION FIRESTOPPING

PART 1 - GENERAL

1.1 SUMMARY

A. Section Includes:

1. Penetrations in fire-resistance-rated walls.
2. Penetrations in horizontal assemblies.
3. Penetrations in smoke barriers.

B. Related Requirements:

1. Section 078443 "Joint Firestopping" for joints in or between fire-resistance-rated construction, at exterior curtain-wall/floor intersections, and in smoke barriers.

1.2 ACTION SUBMITTALS

A. Product Data: For each type of product.

B. Product Schedule: For each penetration firestopping system. Include location, illustration of firestopping system, and design designation of qualified testing and inspecting agency.

1. Engineering Judgments: Where Project conditions require modification to a qualified testing and inspecting agency's illustration for a particular penetration firestopping system, submit illustration, with modifications marked, approved by penetration firestopping system manufacturer's fire-protection engineer as an engineering judgment or equivalent fire-resistance-rated assembly developed in accordance with current International Firestop Council (IFC) guidelines. Obtain approval of authorities having jurisdiction prior to submittal.

1.3 INFORMATIONAL SUBMITTALS

A. Qualification Data: For Installer.

B. Listed System Designs: For each penetration firestopping system, for tests performed by a qualified testing agency.

1.4 CLOSEOUT SUBMITTALS

A. Installer Certificates: From Installer indicating that penetration firestopping systems have been installed in compliance with requirements and manufacturer's written instructions.

1.5 PROJECT CONDITIONS

- A. Environmental Limitations: Do not install penetration firestopping system when ambient or substrate temperatures are outside limits permitted by penetration firestopping system manufacturers or when substrates are wet because of rain, frost, condensation, or other causes.
- B. Install and cure penetration firestopping materials per manufacturer's written instructions using natural means of ventilations or, where this is inadequate, forced-air circulation.

1.6 COORDINATION

- A. Coordinate construction of openings and penetrating items to ensure that penetration firestopping systems can be installed according to specified firestopping system design.
- B. Coordinate sizing of sleeves, openings, core-drilled holes, or cut openings to accommodate penetration firestopping systems.

PART 2 - PRODUCTS

2.1 SOURCE LIMITATIONS

- A. Obtain joint firestop systems for each type of joint opening indicated from single manufacturer.

2.2 PERFORMANCE REQUIREMENTS

- A. Fire-Test-Response Characteristics:
 - 1. Perform penetration firestopping system tests by a qualified testing agency acceptable to authorities having jurisdiction.
 - 2. Test per testing standards referenced in "Penetration Firestopping Systems" Article. Provide rated systems complying with the following requirements:
 - a. Penetration firestop systems installed with products bearing the classification marking of a qualified product certification agency in accordance with listed system designs published by a qualified testing agency.
 - 1) UL in its online directory "Product iQ."
 - 2) Intertek Group in its "Directory of Building Products."
 - 3) FM Approvals in its "Approval Guide."

2.3 PENETRATION FIRESTOPPING SYSTEMS

- A. Penetration Firestopping Systems: Systems that resist spread of fire, passage of smoke and other gases, and maintain original fire-resistance rating of construction penetrated. Penetration firestopping systems are to be compatible with one another, with the substrates forming openings, and with penetrating items if any.

- B. Penetrations in Fire-Resistance-Rated Walls: Penetration firestopping systems with ratings determined per ASTM E814 or UL 1479.
 - 1. F-Rating: Not less than the fire-resistance rating of the wall penetrated.
 - 2. Membrane Penetrations: Install recessed fixtures such that the required fire resistance will not be reduced.
- C. Penetrations in Horizontal Assemblies: Penetration firestopping systems with ratings determined per ASTM E814 or UL 1479.
 - 1. F-Rating: At least one hour, but not less than the fire-resistance rating of the floor penetrated.
 - 2. T-Rating: At least one hour, but not less than the fire-resistance rating of the floor. The following floor penetrations do not require a T-rating:
 - a. Those within the cavity of a wall.
 - b. Floor, tub, or shower drains within a concealed space.
 - c. 4-inch (200-mm) or smaller metal conduit penetrating directly into metal-enclosed electrical switchgear.
- D. Penetrations in Smoke Barriers: Penetration firestopping systems with ratings determined per UL 1479.
 - 1. L-Rating: Not exceeding 5.0 cfm/sq. ft. (0.025 cu. m/s per sq. m) of penetration opening and no more than 50-cfm (0.024-cu. m/s) cumulative total for any 100 sq. ft. (9.3 sq. m) at both ambient and elevated temperatures.
- E. Exposed Penetration Firestopping Systems: Flame-spread and smoke-developed indexes of less than 25 and 450, respectively, per ASTM E84.
- F. Accessories: Provide components for each penetration firestopping system that are needed to install fill materials and to maintain ratings required. Use only those components specified by penetration firestopping system manufacturer and approved by qualified testing and inspecting agency for conditions indicated.
 - 1. Permanent forming/damming/backing materials.
 - 2. Substrate primers.
 - 3. Collars.
 - 4. Steel sleeves.

2.4 FILL MATERIALS

- A. Cast-in-Place Firestop Devices: Factory-assembled devices for use in cast-in-place concrete floors and consisting of an outer sleeve lined with an intumescent strip, a flange attached to one end of the sleeve for fastening to concrete formwork, and a neoprene gasket.
- B. Latex Sealants: Single-component latex formulations that do not re-emulsify after cure during exposure to moisture.
- C. Firestop Devices: Factory-assembled collars formed from galvanized steel and lined with intumescent material sized to fit specific diameter of penetrant.

- D. Intumescent Composite Sheets: Rigid panels consisting of aluminum-foil-faced intumescent elastomeric sheet bonded to galvanized-steel sheet.
- E. Intumescent Putties: Nonhardening, water-resistant, intumescent putties containing no solvents or inorganic fibers.
- F. Intumescent Wrap Strips: Single-component intumescent elastomeric strips for use around combustible penetrants.
- G. Mortars: Prepackaged dry mixes consisting of a blend of inorganic binders, hydraulic cement, fillers and lightweight aggregate formulated for mixing with water at Project site to form a nonshrinking, homogeneous mortar.
- H. Pillows/Bags: Compressible, removable, and reusable intumescent pillows encased in fire-retardant polyester or glass-fiber cloth. Where exposed, cover openings with steel-reinforcing wire mesh to protect pillows/bags from being easily removed.
- I. Silicone Foams: Multicomponent, silicone-based liquid elastomers that, when mixed, expand and cure in place to produce a flexible, nonshrinking foam.
- J. Silicone Sealants: Single-component, silicone-based, neutral-curing elastomeric sealants.
- K. Fire-Rated Cable Sleeve Kits: Complete kits designed for new or existing cable penetrations through walls to accept standard accessories.
- L. Thermal Wrap: Flexible protective wrap tested and listed for up to 2-hour fire ratings in accordance with ASTM E814/UL 1479 for membrane penetrations or ASTM E1725/UL 1724 for thermal barrier and circuit integrity protection.
- M. Fire-Rated Cable Pathways: Single or gangable device modules composed of a steel raceway with integral intumescent material and requiring no additional action in the form of plugs, twisting closure, putty, pillows, sealant, or otherwise to achieve fire and air-leakage ratings.
- N. Retrofit Device for Cable Bundles: Factory-made, intumescent, collar-like device for firestopping existing over-filled cable sleeves and capable of being installed around projecting sleeves and cable bundles.
- O. Wall-Opening Protective Materials: Intumescent, non-curing putty pads or self-adhesive inserts for protection of electrical switch and receptacle boxes.
- P. Fire-Rated HVAC Retaining Angles: Steel angle system with integral intumescent firestop gasket for use around rectangular steel HVAC ducts without fire dampers.
- Q. Firestop Plugs: Flexible, re-enterable, intumescent, foam-rubber plug for use in blank round openings and cable sleeves.
- R. Fire-Rated Cable Grommet: Molded two-piece grommet made of plenum-grade polymer and foam inner core for sealing small cable penetrations in gypsum walls up to 1/2 inch (13 mm) diameter.
- S. Closet Flange Gasket: Molded, single-component, flexible, intumescent gasket for use beneath a water closet (toilet) flange in floor applications.

- T. Endothermic Wrap: Flexible, insulating, fire-resistant, endothermic wrap for protecting membrane penetrations of utility boxes, critical electrical circuits, communications lines, and fuel lines.

2.5 MIXING

- A. Penetration Firestopping Materials: For those products requiring mixing before application, comply with penetration firestopping system manufacturer's written instructions for accurate proportioning of materials, water (if required), type of mixing equipment, selection of mixer speeds, mixing containers, mixing time, and other items or procedures needed to produce products of uniform quality with optimum performance characteristics for application indicated.

PART 3 - EXECUTION

3.1 EXAMINATION

- A. Examine substrates and conditions, with Installer present, for compliance with requirements for opening configurations, penetrating items, substrates, and other conditions affecting performance of the Work.
- B. Proceed with installation only after unsatisfactory conditions have been corrected.

3.2 PREPARATION

- A. Surface Cleaning: Before installing penetration firestopping systems, clean out openings immediately to comply with manufacturer's written instructions and with the following requirements:
 - 1. Remove from surfaces of opening substrates and from penetrating items foreign materials that could interfere with adhesion of penetration firestopping materials.
 - 2. Clean opening substrates and penetrating items to produce clean, sound surfaces capable of developing optimum bond with penetration firestopping materials. Remove loose particles remaining from cleaning operation.
 - 3. Remove laitance and form-release agents from concrete.
- B. Prime substrates where recommended in writing by manufacturer using that manufacturer's recommended products and methods. Confine primers to areas of bond; do not allow spillage and migration onto exposed surfaces.

3.3 INSTALLATION OF PENETRATION FIRESTOPPING SYSTEMS

- A. General: Install penetration firestopping systems to comply with manufacturer's written installation instructions and published drawings for products and applications.
- B. Install forming materials and other accessories of types required to support fill materials during their application and in the position needed to produce cross-sectional shapes and depths required to achieve fire ratings.

1. After installing fill materials and allowing them to fully cure, remove combustible forming materials and other accessories not forming permanent components of firestopping.

C. Install fill materials by proven techniques to produce the following results:

1. Fill voids and cavities formed by openings, forming materials, accessories and penetrating items to achieve required fire-resistance ratings.
2. Apply materials so they contact and adhere to substrates formed by openings and penetrating items.
3. For fill materials that will remain exposed after completing the Work, finish to produce smooth, uniform surfaces that are flush with adjoining finishes.

3.4 IDENTIFICATION

- A. Penetration Identification: Identify each penetration firestopping system with legible metal or plastic labels. Attach labels permanently to surfaces adjacent to and within 6 inches (150 mm) of penetration firestopping system edge so labels are visible to anyone seeking to remove penetrating items or firestopping systems. Use mechanical fasteners or self-adhering-type labels with adhesives capable of permanently bonding labels to surfaces on which labels are placed. Include the following information on labels:

1. The words "Warning - Penetration Firestopping - Do Not Disturb. Notify Building Management of Any Damage."

3.5 CLEANING AND PROTECTION

- A. Clean off excess fill materials adjacent to openings as the Work progresses by methods and with cleaning materials that are approved in writing by penetration firestopping system manufacturers and that do not damage materials in which openings occur.
- B. Provide final protection and maintain conditions during and after installation that ensure that penetration firestopping systems are without damage or deterioration at time of Substantial Completion. If, despite such protection, damage or deterioration occurs, immediately cut out and remove damaged or deteriorated penetration firestopping material and install new materials to produce systems complying with specified requirements.

END OF SECTION 078413

SECTION 079200 - JOINT SEALANTS

PART 1 - GENERAL

1.1 RELATED DOCUMENTS

- A. Drawings and general provisions of the Contract, including General and Supplementary Conditions and Division 01 Specification Sections, apply to this Section.

1.2 SUMMARY

- A. Section Includes:
 - 1. Mildew-resistant joint sealants.
 - 2. Latex joint sealants.

1.3 ACTION SUBMITTALS

- A. Product Data: For each joint-sealant product.
- B. Samples for Initial Selection: Manufacturer's color charts consisting of strips of cured sealants showing the full range of colors available for each product exposed to view.

1.4 INFORMATIONAL SUBMITTALS

- A. Product Test Reports: For each kind of joint sealant, for tests performed by manufacturer and witnessed by a qualified testing agency or a qualified testing agency.

1.5 QUALITY ASSURANCE

- A. Installer Qualifications: An authorized representative who is trained and approved by manufacturer.
- B. Mockups: Install sealant in mockups of assemblies specified in other Sections that are indicated to receive joint sealants specified in this Section. Use materials and installation methods specified in this Section.

1.6 FIELD CONDITIONS

- A. Do not proceed with installation of joint sealants under the following conditions:
 - 1. When ambient and substrate temperature conditions are outside limits permitted by joint-sealant manufacturer.
 - 2. When joint substrates are wet.

3. Where joint widths are less than those allowed by joint-sealant manufacturer for applications indicated.
4. Where contaminants capable of interfering with adhesion have not yet been removed from joint substrates.

PART 2 - PRODUCTS

2.1 JOINT SEALANTS, GENERAL

- A. **Compatibility:** Provide joint sealants, backings, and other related materials that are compatible with one another and with joint substrates under conditions of service and application, as demonstrated by joint-sealant manufacturer, based on testing and field experience.
- B. **Colors of Exposed Joint Sealants:** As indicated in schedule at end of Part 3 or as selected by Architect from manufacturer's full range.

2.2 MILDEW-RESISTANT JOINT SEALANTS

- A. **Mildew-Resistant Joint Sealants:** Formulated for prolonged exposure to humidity with fungicide to prevent mold and mildew growth.
- B. **Silicone, Mildew Resistant, Acid Curing, S, NS, 25, NT:** Mildew-resistant, single-component, nonsag, plus 25 percent and minus 25 percent movement capability, nontraffic-use, acid-curing silicone joint sealant; ASTM C920, Type S, Grade NS, Class 25, Use NT.
 1. **Products:** Subject to compliance with requirements, provide one of the following:
 - a. Dow Corning Corporation; DOW CORNING® 786 SILICONE SEALANT.
 - b. GE Construction Sealants; Momentive Performance Materials Inc.; SCS1700 Sanitary.
 - c. Sika Corporation; Joint Sealants, Sikasil GP
 - d. Pecora Corporation; Pecora 860.
 - e. Soudal USA; RTV GP.
 - f. Tremco Incorporated; Tremsil 200.

2.3 LATEX JOINT SEALANTS

- A. **Acrylic Latex:** Acrylic latex or siliconized acrylic latex, ASTM C834, Type OP, Grade NF.
 1. **Products:** Subject to compliance with requirements, provide one of the following:
 - a. Everkem Diversified Products, Inc.; SilTex 40 Siliconized Acrylic Latex Caulk.
 - b. Pecora Corporation; AC-20.
 - c. Sherwin-Williams Company (The); 950A Siliconized Acrylic Latex Caulk, White or PowerHouse Siliconized Acrylic Latex Sealant.
 - d. Tremco Incorporated; Tremflex 834.

2.4 JOINT-SEALANT BACKING

- A. Sealant Backing Material, General: Nonstaining; compatible with joint substrates, sealants, primers, and other joint fillers; and approved for applications indicated by sealant manufacturer based on field experience and laboratory testing.
- B. Cylindrical Sealant Backings: ASTM C1330, Type C (closed-cell material with a surface skin), Type O (open-cell material), Type B (bicellular material with a surface skin), or any of the preceding types, as approved in writing by joint-sealant manufacturer for joint application indicated, and of size and density to control sealant depth and otherwise contribute to producing optimum sealant performance.
- C. Bond-Breaker Tape: Polyethylene tape or other plastic tape recommended by sealant manufacturer for preventing sealant from adhering to rigid, inflexible joint-filler materials or joint surfaces at back of joint. Provide self-adhesive tape where applicable.

2.5 MISCELLANEOUS MATERIALS

- A. Primer: Material recommended by joint-sealant manufacturer where required for adhesion of sealant to joint substrates indicated, as determined from preconstruction joint-sealant-substrate tests and field tests.
- B. Cleaners for Nonporous Surfaces: Chemical cleaners acceptable to manufacturers of sealants and sealants backing materials, free of oily residues or other substances capable of staining or harming joint substrates and adjacent nonporous surfaces in any way and formulated to promote optimum adhesion of sealants to joint substrates.
- C. Masking Tape: Nonstaining, nonabsorbent material compatible with joint sealants and surfaces adjacent to joints.

PART 3 - EXECUTION

3.1 EXAMINATION

- A. Examine joints indicated to receive joint sealants, with Installer present, for compliance with requirements for joint configuration, installation tolerances, and other conditions affecting performance of the Work.
- B. Proceed with installation only after unsatisfactory conditions have been corrected.

3.2 PREPARATION

- A. Surface Cleaning of Joints: Clean out joints immediately before installing joint sealants to comply with joint-sealant manufacturer's written instructions and the following requirements:
 - 1. Remove all foreign material from joint substrates that could interfere with adhesion of joint sealant, including dust, paints (except for permanent, protective coatings tested and approved for sealant adhesion and compatibility by sealant manufacturer), old joint sealants, oil, grease, waterproofing, water repellents, water, surface dirt, and frost.

2. Clean porous joint substrate surfaces by brushing, grinding, mechanical abrading, or a combination of these methods to produce a clean, sound substrate capable of developing optimum bond with joint sealants. Remove loose particles remaining after cleaning operations above by vacuuming or blowing out joints with oil-free compressed air. Porous joint substrates include the following:
 - a. Concrete.
 - b. Masonry.
 3. Remove laitance and form-release agents from concrete.
 4. Clean nonporous joint substrate surfaces with chemical cleaners or other means that do not stain, harm substrates, or leave residues capable of interfering with adhesion of joint sealants. Nonporous joint substrates include the following:
 - a. Metal.
 - b. Glass.
 - c. Porcelain enamel.
- B. Joint Priming: Prime joint substrates where recommended by joint-sealant manufacturer or as indicated by preconstruction joint-sealant-substrate tests or prior experience. Apply primer to comply with joint-sealant manufacturer's written instructions. Confine primers to areas of joint-sealant bond; do not allow spillage or migration onto adjoining surfaces.
- C. Masking Tape: Use masking tape where required to prevent contact of sealant or primer with adjoining surfaces that otherwise would be permanently stained or damaged by such contact or by cleaning methods required to remove sealant smears. Remove tape immediately after tooling without disturbing joint seal.

3.3 INSTALLATION OF JOINT SEALANTS

- A. General: Comply with joint-sealant manufacturer's written installation instructions for products and applications indicated unless more stringent requirements apply.
- B. Sealant Installation Standard: Comply with recommendations in ASTM C1193 for use of joint sealants as applicable to materials, applications, and conditions indicated.
- C. Install sealant backings of kind indicated to support sealants during application and at position required to produce cross-sectional shapes and depths of installed sealants relative to joint widths that allow optimum sealant movement capability.
 1. Do not leave gaps between ends of sealant backings.
 2. Do not stretch, twist, puncture, or tear sealant backings.
 3. Remove absorbent sealant backings that have become wet before sealant application and replace them with dry materials.
- D. Install bond-breaker tape behind sealants where sealant backings are not used between sealants and backs of joints.
- E. Install sealants using proven techniques that comply with the following and at the same time backings are installed:
 1. Place sealants so they directly contact and fully wet joint substrates.

2. Completely fill recesses in each joint configuration.
3. Produce uniform, cross-sectional shapes and depths relative to joint widths that allow optimum sealant movement capability.

F. Tooling of Nonsag Sealants: Immediately after sealant application and before skinning or curing begins, tool sealants according to requirements specified in subparagraphs below to form smooth, uniform beads of configuration indicated; to eliminate air pockets; and to ensure contact and adhesion of sealant with sides of joint.

1. Remove excess sealant from surfaces adjacent to joints.
2. Use tooling agents that are approved in writing by sealant manufacturer and that do not discolor sealants or adjacent surfaces.
3. Provide concave joint profile per Figure 8A in ASTM C1193 unless otherwise indicated.

3.4 CLEANING

A. Clean off excess sealant or sealant smears adjacent to joints as the Work progresses by methods and with cleaning materials approved in writing by manufacturers of joint sealants and of products in which joints occur.

3.5 PROTECTION

A. Protect joint sealants during and after curing period from contact with contaminating substances and from damage resulting from construction operations or other causes so sealants are without deterioration or damage at time of Substantial Completion. If, despite such protection, damage or deterioration occurs, cut out, remove, and repair damaged or deteriorated joint sealants immediately so installations with repaired areas are indistinguishable from original work.

3.6 JOINT-SEALANT SCHEDULE

A. Joint-Sealant Application: Interior joints in vertical surfaces and horizontal nontraffic surfaces not subject to significant movement.

1. Joint Locations:
 - a. Perimeter joints between painted interior wall surfaces and painted frames of interior windows, and louvers.
2. Joint Sealant: Acrylic latex.
3. Joint-Sealant Color: As selected by Architect from manufacturer's full range of colors.

B. Joint-Sealant Application: Mildew-resistant interior joints in vertical surfaces and horizontal nontraffic surfaces.

1. Joint Locations:
 - a. Joints between plumbing fixtures and adjoining walls, floors, and counters.
 - b. Joints between equipment and walls.
 - c. Joints between counters and walls.

2. Joint Sealant: Silicone, mildew resistant, acid curing, S, NS, 25, NT.
3. Joint-Sealant Color: Clear.

END OF SECTION 079200

SECTION 092900 - GYP SUM BOARD

PART 1 - GENERAL

1.1 SUMMARY

A. Section Includes:

1. Interior gypsum board.

B. Related Requirements:

1. Section 092216 "Non-Structural Metal Framing" for non-structural steel framing that support gypsum board panels.

1.2 ACTION SUBMITTALS

A. Product Data: For the following:

1. Impact-resistant gypsum board.
2. Joint treatment materials.

1.3 DELIVERY, STORAGE AND HANDLING

- A. Store materials inside under cover and keep them dry and protected against weather, condensation, direct sunlight, construction traffic, and other potential causes of damage. Stack panels flat and supported on risers on a flat platform to prevent sagging.

1.4 FIELD CONDITIONS

- A. Environmental Limitations: Comply with ASTM C840 requirements or gypsum board manufacturer's written instructions, whichever are more stringent.
- B. Do not install paper-faced gypsum panels until installation areas are enclosed and conditioned.
- C. Do not install panels that are wet, moisture damaged, and mold damaged.
1. Indications that panels are wet, or moisture damaged include, but are not limited to, discoloration, sagging, or irregular shape.
 2. Indications that panels are mold damaged include, but are not limited to, fuzzy or splotchy surface contamination and discoloration.

PART 2 - PRODUCTS

2.1 GYPSUM BOARD, GENERAL

- A. Size: Provide maximum lengths and widths available that will minimize joints in each area and that correspond with support system indicated.

2.2 INTERIOR GYPSUM BOARD

- A. Gypsum Wallboard: ASTM C1396/C1396M.

- 1. American Gypsum.
- 2. Certaineed; SAINT-GOBAIN.
- 3. Georgia-Pacific Gypsum LLC.
- 4. National Gypsum Company.
- 5. USG Corporation.

- B. Gypsum Board, Type X: ASTM C1396/C1396M.

- 1. Thickness: 5/8 inch (15.9 mm).
- 2. Long Edges: Tapered

2.3 TRIM ACCESSORIES

- A. Interior Trim: ASTM C1047.

- 1. Material: Galvanized or aluminum-coated steel sheet, rolled zinc, plastic, or paper-faced galvanized-steel sheet.
- 2. Shapes:
 - a. Cornerbead.
 - b. LC-Bead: J-shaped; exposed long flange receives joint compound.
 - c. L-Bead: L-shaped; exposed long flange receives joint compound.

2.4 JOINT TREATMENT MATERIALS

- A. General: Comply with ASTM C475/C475M.

- B. Joint Tape:

- 1. Interior Gypsum Board: Paper.
- 2. Exterior Gypsum Soffit Board: Paper.
- 3. Glass-Mat Gypsum Sheathing Board: 10-by-10 glass mesh.
- 4. Tile Backing Panels: As recommended by panel manufacturer.

- C. Joint Compound for Interior Gypsum Board: For each coat, use formulation that is compatible with other compounds applied on previous or for successive coats.

1. Prefilling: At open joints, rounded or beveled panel edges, and damaged surface areas, use setting-type taping compound.
2. Embedding and First Coat: For embedding tape and first coat on joints, fasteners, and trim flanges, use setting-type taping compound.
3. Fill Coat: For second coat, use setting-type, sandable topping compound.
4. Finish Coat: For third coat, use drying-type, all-purpose compound.
5. Skim Coat: For final coat of Level 5 finish, use drying-type, all-purpose compound.

2.5 AUXILIARY MATERIALS

- A. Provide auxiliary materials that comply with referenced installation standards and manufacturer's written instructions.
- B. Steel Drill Screws: ASTM C1002 unless otherwise indicated.
 1. Use screws complying with ASTM C954 for fastening panels to steel members from 0.033 to 0.112 inch (0.84 to 2.84 mm) thick.

PART 3 - EXECUTION

3.1 EXAMINATION

- A. Examine areas and substrates including welded hollow-metal frames and support framing, with Installer present, for compliance with requirements and other conditions affecting performance of the Work.
- B. Examine panels before installation. Reject panels that are wet, moisture damaged, and mold damaged.
- C. Proceed with installation only after unsatisfactory conditions have been corrected.

3.2 INSTALLATION AND FINISHING OF PANELS, GENERAL

- A. Comply with ASTM C840.
- B. Install panels with face side out. Butt panels together for a light contact at edges and ends with not more than 1/16 inch (1.5 mm) of open space between panels. Do not force into place.

- C. Locate edge and end joints over supports, except in ceiling applications where intermediate supports or gypsum board back-blocking is provided behind end joints. Do not place tapered edges against cut edges or ends. Stagger vertical joints on opposite sides of partitions. Do not make joints other than control joints at corners of framed openings.
- D. Form control and expansion joints with space between edges of adjoining gypsum panels.
- E. Cover both faces of support framing with gypsum panels in concealed spaces (above ceilings, etc.), except in chases braced internally.
 - 1. Unless concealed application is indicated or required for sound, fire, air, or smoke ratings, coverage may be accomplished with scraps of not less than 8 sq. ft. (0.7 sq. m) in area.
 - 2. Fit gypsum panels around ducts, pipes, and conduits.
 - 3. Where partitions intersect structural members projecting below underside of floor/roof slabs and decks, cut gypsum panels to fit profile formed by structural members; allow 1/4- to 3/8-inch- (6.4- to 9.5-mm-) wide joints to install sealant.
- F. Isolate perimeter of gypsum board applied to non-load-bearing partitions at structural abutments. Provide 1/4- to 1/2-inch- (6.4- to 12.7-mm-) wide spaces at these locations and trim edges with edge trim where edges of panels are exposed. Seal joints between edges and abutting structural surfaces with acoustical sealant.
- G. Attachment to Steel Framing: Attach panels so leading edge or end of each panel is attached to open (unsupported) edges of stud flanges first.

3.3 INSTALLATION OF TRIM ACCESSORIES

- A. General: For trim with back flanges intended for fasteners, attach to framing with same fasteners used for panels. Otherwise, attach trim according to manufacturer's written instructions.
- B. Control Joints: Install control joints according to ASTM C840 and in specific locations approved by Architect for visual effect.
- C. Interior Trim: Install in the following locations:
 - 1. Cornerbead: Use at outside corners unless otherwise indicated.
 - 2. LC-Bead: Use at exposed panel edges.

3.4 FINISHING GYPSUM BOARD

- A. General: Treat gypsum board joints, interior angles, edge trim, control joints, penetrations, fastener heads, surface defects, and elsewhere as required to prepare gypsum board surfaces for decoration. Promptly remove residual joint compound from adjacent surfaces.
- B. Prefill open joints and damaged surface areas.
- C. Apply joint tape over gypsum board joints, except for trim products specifically indicated as not intended to receive tape.

- D. Gypsum Board Finish Levels: Finish panels to levels indicated below and according to ASTM C840:
1. Level 1: Ceiling plenum areas, concealed areas, and where indicated.
 2. Level 4: At panel surfaces that will be exposed to view unless otherwise indicated.
 - a. Primer and its application to surfaces are specified in Section 099123 "Interior Painting."

3.5 PROTECTION

- A. Protect adjacent surfaces from drywall compound and promptly remove from floors and other non-drywall surfaces. Repair surfaces stained, marred, or otherwise damaged during drywall application.
- B. Protect installed products from damage from weather, condensation, direct sunlight, construction, and other causes during remainder of the construction period.
- C. Remove and replace panels that are wet, moisture damaged, and mold damaged.
1. Indications that panels are wet, or moisture damaged include, but are not limited to, discoloration, sagging, or irregular shape.
 2. Indications that panels are mold damaged include, but are not limited to, fuzzy or splotchy surface contamination and discoloration.

END OF SECTION 092900

SECTION 096513 - RESILIENT BASE AND ACCESSORIES

PART 1 - GENERAL

1.1 RELATED DOCUMENTS

- A. Drawings and general provisions of the Contract, including General and Supplementary Conditions and Division 01 Specification Sections, apply to this Section.

1.2 SUMMARY

- A. Section Includes:
 - 1. Vinyl base.

1.3 ACTION SUBMITTALS

- A. Product Data: For each type of product.
- B. Samples: For each exposed product and for each color and texture specified.
- C. Samples for Verification: For each type of product indicated and for each color, texture, and pattern required in manufacturer's standard-size Samples.
- D. Product Schedule: For resilient base and accessory products. Use same designations indicated on Drawings.

1.4 MAINTENANCE MATERIAL SUBMITTALS

- A. Furnish extra materials, from the same product run, that match products installed and that are packaged with protective covering for storage and identified with labels describing contents.
 - 1. Furnish not less than 10 linear feet (3 linear m) for every 500 linear feet (150 linear m) or fraction thereof, of each type, color, pattern, and size of resilient product installed.

1.5 DELIVERY, STORAGE, AND HANDLING

- A. Store resilient products and installation materials in dry spaces protected from the weather, with ambient temperatures maintained within range recommended by manufacturer, but not less than 50 deg F (10 deg C) or more than 90 deg F (32 deg C).

1.6 FIELD CONDITIONS

- A. Maintain ambient temperatures within range recommended by manufacturer, but not less than 70 deg F (21 deg C) or more than 95 deg F (35 deg C), in spaces to receive resilient products during the following periods:
 - 1. 48 hours before installation.
 - 2. During installation.
 - 3. 48 hours after installation.
- B. After installation and until Substantial Completion, maintain ambient temperatures within range recommended by manufacturer, but not less than 55 deg F (13 deg C) or more than 95 deg F (35 deg C).
- C. Install resilient products after other finishing operations, including painting, have been completed.

PART 2 - PRODUCTS

2.1 VINYL BASE RB1

- A. Manufacturers: Subject to compliance with requirements, provide products by one of the following:
 - 1. Armstrong World Industries, Inc.
 - 2. Burke Mercer Flooring Products; a division of Burke Industries Inc.
 - 3. Flexco; Roppe Holding Company.
 - 4. Johnsonite; a Tarkett company.
 - 5. Roppe Corporation; Roppe Holding Company.
 - 6. VPI Corporation.
- B. Product Standard: ASTM F1861, Type TV (vinyl, thermoplastic).
 - 1. Group: I (solid, homogeneous).
 - 2. Style and Location:
 - a. Style B, Cove.
- C. Minimum Thickness: 0.125 inch (3.2 mm).
- D. Height: 4 inches (102 mm).
- E. Lengths: Cut lengths 48 inches (1219 mm) long or Coils in manufacturer's standard length.
- F. Outside Corners: Job formed.
- G. Inside Corners: Job formed.
- H. Colors and Patterns: As indicated by manufacturer's designations in drawings.

2.2 INSTALLATION MATERIALS

- A. Trowelable Leveling and Patching Compounds: Latex-modified, portland-cement-based or blended hydraulic-cement-based formulation provided or approved by resilient-product manufacturer for applications indicated.
- B. Adhesives: Water-resistant type recommended by resilient-product manufacturer for resilient products and substrate conditions indicated.

PART 3 - EXECUTION

3.1 EXAMINATION

- A. Examine substrates, with Installer present, for compliance with requirements for maximum moisture content and other conditions affecting performance of the Work.
 - 1. Verify that finishes of substrates comply with tolerances and other requirements specified in other Sections and that substrates are free of cracks, ridges, depressions, scale, and foreign deposits that might interfere with adhesion of resilient products.
- B. Proceed with installation only after unsatisfactory conditions have been corrected.
 - 1. Installation of resilient products indicates acceptance of surfaces and conditions.

3.2 PREPARATION

- A. Prepare substrates according to manufacturer's written instructions to ensure adhesion of resilient products.
- B. Fill cracks, holes, and depressions in substrates with trowelable leveling and patching compound; remove bumps and ridges to produce a uniform and smooth substrate.
- C. Do not install resilient products until materials are the same temperature as space where they are to be installed.
 - 1. At least 48 hours in advance of installation, move resilient products and installation materials into spaces where they will be installed.
- D. Immediately before installation, sweep and vacuum clean substrates to be covered by resilient products.

3.3 RESILIENT BASE INSTALLATION

- A. Comply with manufacturer's written instructions for installing resilient base.
- B. Apply resilient base to walls, columns, pilasters, casework and cabinets in toe spaces, and other permanent fixtures in rooms and areas where base is required.

- C. Install resilient base in lengths as long as practical without gaps at seams and with tops of adjacent pieces aligned.
- D. Tightly adhere resilient base to substrate throughout length of each piece, with base in continuous contact with horizontal and vertical substrates.
- E. Do not stretch resilient base during installation.
- F. On masonry surfaces or other similar irregular substrates, fill voids along top edge of resilient base with manufacturer's recommended adhesive filler material.
- G. Job-Formed Corners:
 - 1. Outside Corners: Use straight pieces of maximum lengths possible and form with returns not less than 3 inches (76 mm) in length.
 - a. Form without producing discoloration (whitening) at bends.
 - 2. Inside Corners: Use straight pieces of maximum lengths possible and form with returns not less than 3 inches (76 mm) in length.
 - a. Miter corners to minimize open joints.

3.4 CLEANING AND PROTECTION

- A. Comply with manufacturer's written instructions for cleaning and protecting resilient products.
- B. Perform the following operations immediately after completing resilient-product installation:
 - 1. Remove adhesive and other blemishes from surfaces.
 - 2. Sweep and vacuum horizontal surfaces thoroughly.
 - 3. Damp-mop horizontal surfaces to remove marks and soil.
- C. Protect resilient products from mars, marks, indentations, and other damage from construction operations and placement of equipment and fixtures during remainder of construction period.
- D. Cover resilient products subject to wear and foot traffic until Substantial Completion.

END OF SECTION 096513

SECTION 096519 - RESILIENT TILE FLOORING

PART 1 - GENERAL

1.1 RELATED DOCUMENTS

- A. Drawings and general provisions of the Contract, including General and Supplementary Conditions and Division 01 Specification Sections, apply to this Section.

1.2 SUMMARY

- A. Section Includes:
 - 1. Vinyl composition floor tile.

1.3 ACTION SUBMITTALS

- A. Product Data: For each type of product.
- B. Samples for Initial Selection: For each type of floor tile indicated.
- C. Product Schedule: For floor tile. Use same designations indicated on Drawings.

1.4 INFORMATIONAL SUBMITTALS

- A. Qualification Data: For Installer.

1.5 CLOSEOUT SUBMITTALS

- A. Maintenance Data: For each type of floor tile to include in maintenance manuals.

1.6 MAINTENANCE MATERIAL SUBMITTALS

- A. Furnish extra materials, from the same product run, that match products installed and that are packaged with protective covering for storage and identified with labels describing contents.
 - 1. Floor Tile: Furnish one box for every 50 boxes or fraction thereof, of each type, color, and pattern of floor tile installed.

1.7 QUALITY ASSURANCE

- A. Installer Qualifications: An entity that employs installers and supervisors who are competent in techniques required by manufacturer for floor tile installation and seaming method indicated.

1. Engage an installer who employs workers for this Project who are trained or certified by floor tile manufacturer for installation techniques required.

1.8 DELIVERY, STORAGE, AND HANDLING

- A. Store floor tile and installation materials in dry spaces protected from the weather, with ambient temperatures maintained within range recommended by manufacturer, but not less than 50 deg F (10 deg C) or more than 90 deg F (32 deg C). Store floor tiles on flat surfaces.

1.9 FIELD CONDITIONS

- A. Maintain ambient temperatures within range recommended by manufacturer, but not less than 70 deg F (21 deg C) or more than 95 deg F (35 deg C), in spaces to receive floor tile during the following periods:
 1. 48 hours before installation.
 2. During installation.
 3. 48 hours after installation.
- B. After installation and until Substantial Completion, maintain ambient temperatures within range recommended by manufacturer, but not less than 55 deg F (13 deg C) or more than 95 deg F (35 deg C).
- C. Close spaces to traffic during floor tile installation.
- D. Close spaces to traffic for 48 hours after floor tile installation.
- E. Install floor tile after other finishing operations, including painting, have been completed.

PART 2 - PRODUCTS

2.1 PERFORMANCE REQUIREMENTS

- A. Fire-Test-Response Characteristics: For resilient floor tile, as determined by testing identical products according to ASTM E 648 or NFPA 253 by a qualified testing agency.
 1. Critical Radiant Flux Classification: Class I, not less than 0.45 W/sq. cm.

2.2 VINYL COMPOSITION FLOOR TILE

- A. Manufacturers: Subject to compliance with requirements, provide products by one of the following:
 1. Armstrong World Industries, Inc.
 2. Johnsonite; a Tarkett company.
 3. Mannington Mills, Inc.

- B. Tile Standard: ASTM F 1066, Class 2, through pattern.
- C. Wearing Surface: Smooth.
- D. Thickness: 0.125 inch (3.2 mm).
- E. Size: 12 by 12 inches (305 by 305 mm).
- F. Colors and Patterns: As selected from manufacturer's full range to match existing resilient tile flooring

2.3 INSTALLATION MATERIALS

- A. Trowelable Leveling and Patching Compounds: Latex-modified, portland-cement-based or blended hydraulic-cement-based formulation provided or approved by floor tile manufacturer for applications indicated.
- B. Adhesives: Water-resistant type recommended by floor tile and adhesive manufacturers to suit floor tile and substrate conditions indicated.

PART 3 - EXECUTION

3.1 EXAMINATION

- A. Examine substrates, with Installer present, for compliance with requirements for maximum moisture content and other conditions affecting performance of the Work.
 - 1. Verify that finishes of substrates comply with tolerances and other requirements specified in other Sections and that substrates are free of cracks, ridges, depressions, scale, and foreign deposits that might interfere with adhesion of floor tile.
- B. Proceed with installation only after unsatisfactory conditions have been corrected.

3.2 PREPARATION

- A. Prepare substrates according to floor tile manufacturer's written instructions to ensure adhesion of resilient products.
- B. Concrete Substrates: Prepare according to ASTM F 710.
 - 1. Verify that substrates are dry and free of curing compounds, sealers, and hardeners.
 - 2. Remove substrate coatings and other substances that are incompatible with adhesives and that contain soap, wax, oil, or silicone, using mechanical methods recommended by floor tile manufacturer. Do not use solvents.
 - 3. Alkalinity and Adhesion Testing: Perform tests recommended by floor tile manufacturer. Proceed with installation only after substrate alkalinity falls within range on pH scale recommended by manufacturer in writing, but not less than 5 or more than 9 pH.

4. Moisture Testing: Perform tests so that each test area does not exceed 200 sq. ft., and perform no fewer than three tests in each installation area and with test areas evenly spaced in installation areas.
- C. Fill cracks, holes, and depressions in substrates with trowelable leveling and patching compound; remove bumps and ridges to produce a uniform and smooth substrate.
- D. Do not install floor tiles until materials are the same temperature as space where they are to be installed.
 1. At least 48 hours in advance of installation, move resilient floor tile and installation materials into spaces where they will be installed.
- E. Immediately before installation, sweep and vacuum clean substrates to be covered by resilient floor tile.

3.3 FLOOR TILE INSTALLATION

- A. Comply with manufacturer's written instructions for installing floor tile.
- B. Lay out floor tiles from center marks established with principal walls, discounting minor offsets, so tiles at opposite edges of room are of equal width. Adjust as necessary to avoid using cut widths that equal less than one-half tile at perimeter.
 1. Lay tiles square with room axis.
- C. Match floor tiles for color and pattern by selecting tiles from cartons in the same sequence as manufactured and packaged, if so numbered. Discard broken, cracked, chipped, or deformed tiles.
 1. Lay tiles with grain running in one direction.
- D. Scribe, cut, and fit floor tiles to butt neatly and tightly to vertical surfaces and permanent fixtures including built-in furniture, cabinets, pipes, outlets, and door frames.
- E. Extend floor tiles into toe spaces, door reveals, closets, and similar openings. Extend floor tiles to center of door openings.
- F. Maintain reference markers, holes, and openings that are in place or marked for future cutting by repeating on floor tiles as marked on substrates. Use chalk or other nonpermanent marking device.
- G. Install floor tiles on covers for telephone and electrical ducts, building expansion-joint covers, and similar items in installation areas. Maintain overall continuity of color and pattern between pieces of tile installed on covers and adjoining tiles. Tightly adhere tile edges to substrates that abut covers and to cover perimeters.
- H. Adhere floor tiles to substrates using a full spread of adhesive applied to substrate to produce a completed installation without open cracks, voids, raising and puckering at joints, telegraphing of adhesive spreader marks, and other surface imperfections.

3.4 CLEANING AND PROTECTION

- A. Comply with manufacturer's written instructions for cleaning and protecting floor tile.
- B. Perform the following operations immediately after completing floor tile installation:
 - 1. Remove adhesive and other blemishes from surfaces.
 - 2. Sweep and vacuum surfaces thoroughly.
 - 3. Damp-mop surfaces to remove marks and soil.
- C. Protect floor tile from mars, marks, indentations, and other damage from construction operations and placement of equipment and fixtures during remainder of construction period.
- D. Cover floor tile until Substantial Completion.

END OF SECTION 096519

SECTION 099124 - INTERIOR PAINTING (MPI STANDARDS)

PART 1 - GENERAL

1.1 RELATED DOCUMENTS

- A. Drawings and general provisions of the Contract, including General and Supplementary Conditions and Division 01 Specification Sections, apply to this Section.

1.2 SUMMARY

- A. Section includes surface preparation and the application of paint systems on the following interior substrates:
 - 1. Concrete masonry units (CMUs).
 - 2. Steel and iron.
 - 3. Gypsum board.

1.3 DEFINITIONS

- A. MPI Gloss Level 1: Not more than five units at 60 degrees and 10 units at 85 degrees, according to ASTM D523.
- B. MPI Gloss Level 2: Not more than 10 units at 60 degrees and 10 to 35 units at 85 degrees, according to ASTM D523.
- C. MPI Gloss Level 3: 10 to 25 units at 60 degrees and 10 to 35 units at 85 degrees, according to ASTM D523.
- D. MPI Gloss Level 4: 20 to 35 units at 60 degrees and not less than 35 units at 85 degrees, according to ASTM D523.
- E. MPI Gloss Level 5: 35 to 70 units at 60 degrees, according to ASTM D523.
- F. MPI Gloss Level 6: 70 to 85 units at 60 degrees, according to ASTM D523.
- G. MPI Gloss Level 7: More than 85 units at 60 degrees, according to ASTM D523.

1.4 ACTION SUBMITTALS

- A. Product Data: For each type of product. Include preparation requirements and application instructions.
 - 1. Include printout of current "MPI Approved Products List" for each product category specified, with the proposed product highlighted.
 - 2. Indicate VOC content.

- B. Product List: Use same designations indicated on Drawings and in the Interior Painting Schedule to cross-reference paint systems specified in this Section. Include color designations.

1.5 MAINTENANCE MATERIAL SUBMITTALS

- A. Furnish extra materials, from the same product run, that match products installed and that are packaged with protective covering for storage and identified with labels describing contents.
 - 1. Paint: 5 percent, but not less than 1 gal. (3.8 L) of each material and color applied.

1.6 DELIVERY, STORAGE, AND HANDLING

- A. Store materials not in use in tightly covered containers in well-ventilated areas with ambient temperatures continuously maintained at not less than 45 deg F (7 deg C).
 - 1. Maintain containers in clean condition, free of foreign materials and residue.
 - 2. Remove rags and waste from storage areas daily.

1.7 FIELD CONDITIONS

- A. Apply paints only when temperature of surfaces to be painted and ambient air temperatures are between 50 and 95 deg F (10 and 35 deg C).
- B. Do not apply paints when relative humidity exceeds 85 percent; at temperatures of less than 5 deg F (3 deg C) above the dew point; or to damp or wet surfaces.

PART 2 - PRODUCTS

2.1 PAINT, GENERAL

- A. MPI Standards: Products shall comply with MPI standards indicated and shall be listed in its "MPI Approved Products List."
- B. Material Compatibility:
 - 1. Materials for use within each paint system shall be compatible with one another and substrates indicated, under conditions of service and application as demonstrated by manufacturer, based on testing and field experience.
 - 2. For each coat in a paint system, products shall be recommended in writing by topcoat manufacturers for use in paint system and on substrate indicated.
- C. Colors: As indicated in drawings.

PART 3 - EXECUTION

3.1 EXAMINATION

- A. Examine substrates and conditions, with Applicator present, for compliance with requirements for maximum moisture content and other conditions affecting performance of the Work.
- B. Maximum Moisture Content of Substrates: When measured with an electronic moisture meter as follows:
 - 1. Masonry (Clay and CMUs): 12 percent.
 - 2. Gypsum Board: 12 percent.
- C. Gypsum Board Substrates: Verify that finishing compound is sanded smooth.
- D. Verify suitability of substrates, including surface conditions and compatibility, with existing finishes and primers.
- E. Proceed with coating application only after unsatisfactory conditions have been corrected.
 - 1. Application of coating indicates acceptance of surfaces and conditions.

3.2 PREPARATION

- A. Comply with manufacturer's written instructions and recommendations in "MPI Architectural Painting Specification Manual" applicable to substrates and paint systems indicated.
- B. Remove hardware, covers, plates, and similar items already in place that are removable and are not to be painted. If removal is impractical or impossible because of size or weight of item, provide surface-applied protection before surface preparation and painting.
 - 1. After completing painting operations, use workers skilled in the trades involved to reinstall items that were removed. Remove surface-applied protection if any.
- C. Clean substrates of substances that could impair bond of paints, including dust, dirt, oil, grease, and incompatible paints and encapsulants.
 - 1. Remove incompatible primers and reprime substrate with compatible primers or apply tie coat as required to produce paint systems indicated.
- D. Masonry Substrates: Remove efflorescence and chalk. Do not paint surfaces if moisture content or alkalinity of surfaces or mortar joints exceeds that permitted in manufacturer's written instructions.
- E. Steel Substrates: Remove rust, loose mill scale, and shop primer, if any. Clean using methods recommended in writing by paint manufacturer but not less than the following:
 - 1. SSPC-SP 2.

- F. Shop-Primed Steel Substrates: Clean field welds, bolted connections, and areas where shop paint is abraded. Paint exposed areas with the same material as used for shop priming to comply with SSPC-PA 1 for touching up shop-primed surfaces.
- G. Galvanized-Metal Substrates: Remove grease and oil residue from galvanized sheet metal by mechanical methods to produce clean, lightly etched surfaces that promote adhesion of subsequently applied paints.
- H. Aluminum Substrates: Remove loose surface oxidation.

3.3 INSTALLATION

- A. Apply paints according to manufacturer's written instructions and to recommendations in "MPI Manual."
 - 1. Use applicators and techniques suited for paint and substrate indicated.
 - 2. Paint surfaces behind movable equipment and furniture same as similar exposed surfaces. Before final installation, paint surfaces behind permanently fixed equipment or furniture with prime coat only.
 - 3. Paint front and backsides of access panels, removable or hinged covers, and similar hinged items to match exposed surfaces.
 - 4. Do not paint over labels of independent testing agencies or equipment name, identification, performance rating, or nomenclature plates.
 - 5. Primers specified in painting schedules may be omitted on items that are factory primed or factory finished if acceptable to topcoat manufacturers.
- B. Tint each undercoat a lighter shade to facilitate identification of each coat if multiple coats of same material are to be applied. Tint undercoats to match color of topcoat but provide sufficient difference in shade of undercoats to distinguish each separate coat.
- C. If undercoats or other conditions show through topcoat, apply additional coats until cured film has a uniform paint finish, color, and appearance.
- D. Apply paints to produce surface films without cloudiness, spotting, holidays, laps, brush marks, roller tracking, runs, sags, ropiness, or other surface imperfections. Cut in sharp lines and color breaks.
- E. Painting Fire-Suppression, Plumbing, HVAC, Electrical, Communication, and Electronic Safety and Security Work:
 - 1. Paint the following work where exposed in occupied spaces:
 - a. Uninsulated metal piping.
 - b. Uninsulated plastic piping.
 - c. Pipe hangers and supports.
 - d. Metal conduit.
 - e. Plastic conduit.
 - f. Duct, equipment, and pipe insulation having cotton or canvas insulation covering or other paintable jacket material.
 - g. Other items as directed in drawings.

3.4 FIELD QUALITY CONTROL

- A. Dry-Film Thickness Testing: Owner may engage the services of a qualified testing and inspecting agency to inspect and test paint for dry-film thickness.
 - 1. Contractor shall touch up and restore painted surfaces damaged by testing.
 - 2. If test results show that dry-film thickness of applied paint does not comply with paint manufacturer's written recommendations, Contractor shall pay for testing and apply additional coats as needed to provide dry-film thickness that complies with paint manufacturer's written recommendations.

3.5 CLEANING AND PROTECTION

- A. At end of each workday, remove rubbish, empty cans, rags, and other discarded materials from Project site.
- B. After completing paint application, clean spattered surfaces. Remove spattered paints by washing, scraping, or other methods. Do not scratch or damage adjacent finished surfaces.
- C. Protect work of other trades against damage from paint application. Correct damage to work of other trades by cleaning, repairing, replacing, and refinishing, as approved by Architect, and leave in an undamaged condition.
- D. At completion of construction activities of other trades, touch up and restore damaged or defaced painted surfaces.

3.6 INTERIOR PAINTING SCHEDULE

- A. CMU Substrates:
 - 1. Latex System, MPI INT 4.2A:
 - a. Block Filler: Block filler, latex, interior/exterior, MPI #4.
 - b. Intermediate Coat: Latex, interior, matching topcoat.
 - c. Topcoat: Latex, interior, semigloss (MPI Gloss Level 5), MPI #54.
- B. Steel Substrates:
 - 1. Latex System, Alkyd Primer, MPI INT 5.1Q:
 - a. Prime Coat: Primer, alkyd, quick dry, for metal, MPI #76.
 - b. Intermediate Coat: Latex, interior, matching topcoat.
 - c. Topcoat: Latex, interior, semigloss (MPI Gloss Level 5), MPI #54.
 - 2. Latex over Shop-Applied Quick-Drying Shop Primer System:
 - a. Prime Coat: Shop primer specified in Section where substrate is specified.
 - b. Intermediate Coat: Latex, interior, matching topcoat.
 - c. Topcoat: Latex, interior, semigloss (MPI Gloss Level 5), MPI #54.
 - 3. Water-Based Dry-Fall System, MPI INT 5.1C:

- a. Prime Coat: Primer, alkyd, quick dry, for metal, MPI #76.
- b. Prime Coat: Shop primer specified in Section where substrate is specified.
- c. Topcoat: Dry fall, latex (MPI Gloss Level 5), MPI #226.

C. Gypsum Board Substrates:

1. Latex over Latex Sealer System, MPI INT 9.2A:

- a. Prime Coat: Primer sealer, latex, interior, MPI #50.
- b. Intermediate Coat: Latex, interior, matching topcoat.
- c. Topcoat: Latex, interior, semigloss (MPI Gloss Level 5), MPI #54.

D. Previously Painted Substrates:

1. Latex over Latex Sealer System:

- a. Prime Coat: Latex, interior, matching topcoat.
- b. Topcoat: Latex, interior, semigloss (MPI Gloss Level 5), MPI #54.

END OF SECTION 099124

SECTION 123553 - LABORATORY CASEWORK

PART 1 - GENERAL

1.1 SUMMARY

A. Section Includes:

1. Laboratory countertops.
2. Laboratory Sinks
3. Laboratory Accessories
4. Gas Cylinder Racks
5. Water, Laboratory gas, and electrical service fittings

B. Related Requirements:

1. Section 096513 "Resilient Base and Accessories" for resilient base applied to laboratory casework.
2. Section 115313 "Laboratory Fume Hoods" for fume hoods, including base cabinets and countertops under fume hoods

1.2 DEFINITIONS

A. Concealed Surfaces of Casework: Include sleepers, web frames, dust panels, and other surfaces not usually visible after installation.

B. Exposed Surfaces of Casework: Surfaces visible when doors and drawers are closed, including bottoms of cabinets more than 48 inches (1200 mm) above floor, and visible surfaces in open cabinets or behind glass doors.

1. Ends of cabinets are defined as "exposed" except ends are defined as "concealed" where installed directly against and completely concealed by walls or other cabinets.

C. Semiexposed Surfaces of Casework: Surfaces behind opaque doors, such as cabinet interiors, shelves, and dividers; interiors and sides of drawers; and interior faces of doors. Tops of cases 78 inches (1980 mm) or more above floor and bottoms of cabinets more than 24 inches (600 mm) but less than 48 inches (1200 mm) above floor are defined as "semiexposed."

1.3 PREINSTALLATION MEETINGS

A. Preinstallation Conference: Conduct conference at Project site.

1.4 COORDINATION

A. Coordinate layout and installation of framing and reinforcements for support of laboratory casework.

B. Coordinate installation of laboratory casework with installation of laboratory equipment.

1.5 ACTION SUBMITTALS

- A. Product Data: For each type of product.
- B. Shop Drawings: For laboratory casework.
 - 1. Include plans, elevations, sections, and attachments to other work including blocking and reinforcements required for installation.
 - 2. Indicate types and sizes of casework.
 - 3. Indicate manufacturer's catalog numbers for casework.
 - 4. Show fabrication details, including types and locations of hardware.
 - 5. Indicate locations and types of service fittings.
 - 6. Indicate locations of and clearances from adjacent walls, doors, windows, other building components, and laboratory equipment.
- C. Samples: For casework finishes and materials requiring color selection.
- D. Samples for Initial Selection: For casework finishes and materials requiring color selection.

1.6 INFORMATIONAL SUBMITTALS

- A. Qualification Data: For manufacturer.
- B. Product Test Reports:
 - 1. Casework: Based on evaluation of comprehensive tests performed by a qualified testing agency, indicating compliance of laboratory casework with requirements of specified product standard and system structural performance specified in "Performance Requirements" Article.
 - 2. Countertop Surface Material: Based on evaluation of comprehensive tests performed by a qualified testing agency, indicating compliance of laboratory countertop surface material with requirements specified for chemical and physical resistance.

1.7 MAINTENANCE MATERIAL SUBMITTALS

- A. Furnish complete touchup kit for each type and color of casework finish provided. Include fillers, stains, finishes, and other materials necessary to perform permanent repairs to damaged laboratory casework finish.
- B. Furnish extra materials that match products installed and that are packaged with protective covering for storage and identified with labels describing contents.
 - 1. Cabinet Mounting Clips and Related Hardware: Quantity equal to 5 percent of amount installed, but no fewer than 20 of each type.

1.8 QUALITY ASSURANCE

- A. Manufacturer Qualifications: A qualified manufacturer that produces casework of types indicated for this Project that has been tested for compliance with SEFA 8 W.

1.9 DELIVERY, STORAGE, AND HANDLING

- A. Protect finished surfaces during handling and installation with protective covering of polyethylene film or other suitable material.

1.10 FIELD CONDITIONS

- A. Environmental Limitations: Do not deliver or install laboratory casework until building is enclosed, utility roughing-in and wet-work are complete, and HVAC system is operating and maintaining temperature and relative humidity at levels planned for building occupants during the remainder of the construction period.
- B. Established Dimensions: Where laboratory casework is indicated to fit to other construction, establish dimensions for areas where casework is to fit. Provide allowance for trimming at site, and coordinate construction to ensure that actual dimensions correspond to established dimensions.
- C. Field Measurements: Where laboratory casework is indicated to fit to existing construction, verify dimensions of existing construction by field measurements before fabrication and indicate measurements on Shop Drawings. Provide fillers and scribes to allow for trimming and fitting.
- D. Locate concealed framing, blocking, and reinforcements that support casework by field measurements before enclosing them, and indicate measurements on Shop Drawings.

PART 2 - PRODUCTS

2.1 PERFORMANCE REQUIREMENTS

- A. System Structural Performance: Laboratory casework and support framing system shall withstand the effects of the following gravity loads and stresses without permanent deformation, excessive deflection, or binding of drawers and doors:
 - 1. Support Framing System: 600 lb/ft. (900 kg/m).
 - 2. Work Surfaces 160 lb/ft. (240 kg/m).
 - 3. Shelves: 40 lb/sq. ft. (200 kg/sq. m).

2.2 CASEWORK, GENERAL

- A. Casework Product Standard: Comply with SEFA 8 W, "Laboratory Grade Wood Casework."

2.3 COUNTERTOP MATERIALS

- A. Phenolic Composite: Solid, high-pressure decorative laminate, complying with NEMA LD 3, Grade CGS.
 - 1. Manufacturers: Subject to compliance with requirements, available manufacturers offering products that may be incorporated into the Work include, but are not limited to the following:

- a. Trespa North America.
 - b. Fundermax, Max Resistance²
2. Chemical Resistance: Composite countertop material has the following ratings when tested with indicated reagents according to NEMA LD 3, Test Procedure 3.4.5:
- a. No Effect: Acetic acid (98 percent), acetone, ammonium hydroxide (28 percent), ethyl acetate, ethyl alcohol, formaldehyde (37 percent), furfural, phosphoric acid (85 percent), sulfuric acid (33 percent), toluene, benzene carbon tetrachloride dimethyl formamide hydrochloric acid (37 percent) hydrofluoric acid (48 percent) nitric acid (30 percent) sodium hydroxide (20 percent) and zinc chloride.
3. Color: As selected by Architect from phenolic-composite manufacturer's full range. Refer to drawings for basis-of-design.

2.4 COUNTERTOPS AND SINKS

- A. Countertops, General: Provide units with smooth surfaces in uniform plane, free of defects. Make exposed edges and corners straight and uniformly beveled. Provide front and end overhang of 1 inch (25 mm).
- B. Phenolic-Composite Countertops:
1. Countertop Fabrication: Fabricate with cutouts for sinks, holes for service fittings and accessories, and butt joints assembled with epoxy adhesive and concealed metal splines.
 - a. Flat Configuration: 3/4 inch (19 mm) thick with continuous drip groove on underside 1/2 inch (13 mm) from overhang edge and integral coved backsplash.
 - 1) Edges and Corners: Beveled.
- C. Epoxy Sinks, General: Provide sizes indicated or laboratory casework manufacturer's closest standard size of equal or greater volume, as approved by Architect.
1. Outlets: Provide with strainers and tailpieces, NPS 1-1/2 (DN 40), unless otherwise indicated.
 2. Overflows: For each sink, provide overflow of standard beehive or open-top design with separate strainer. Height 2 inches (50 mm) less than sink depth. Provide in same material as strainer.

2.5 LABORATORY ACCESSORIES

- A. Plastic or Resin Pegboards: Polypropylene, epoxy, or phenolic-composite pegboards with removable polypropylene pegs and stainless-steel drip troughs with drain outlet.
- B. Exposed Countertop Support Brackets: Surface mounted workstation brackets sized to support depth of counter/shelf indicated on drawings. Paint Black
1. Manufacturers: As selected from list below.
 - a. US Futaba; Hybrid Bracket.

- b. Chemical Concepts; Counterbalance Workstation Bracket.
 - C. A&M Hardware; Workstation Bracket
 - D. Wire-Management Grommets: Circular, molded-plastic grommets and matching plastic caps with slot for wire passage.
 - 1. Outside Diameter: 2 inches (51 mm).
 - 2. Color: Black.
- 2.6 GAS CYLINDER RACK
- A. Square steel tube barricade rack for bulk gas cylinder storage.
 - B. 2-inch tube steel continuously seam welded and powder coated finish
 - C. Welded steel chains and snaps for each cylinder
 - D. Rack Configuration to be 2 cylinders deep. Refer to drawings for number of cylinders wide for each rack.
- 2.7 WATER AND LABORATORY GAS SERVICE FITTINGS
- A. Manufacturers: Subject to compliance with requirements, provide products by one of the following:
 - 1. Chicago Faucets; Geberit Company.
 - 2. WaterSaver Faucet Co.
 - B. Service Fittings: Provide units that comply with SEFA 7, "Recommended Practices for Fixtures." Provide fittings complete with washers, locknuts, nipples, and other installation accessories. Include wall and deck flanges, escutcheons, handle extension rods, and similar items.
 - 1. Provide units that comply with "Vandal-Resistant Faucets and Fixtures" recommendations in SEFA 7.
 - C. Materials: Fabricated from cast or forged red brass unless otherwise indicated.
 - 1. Reagent-Grade Water Service Fittings: Polypropylene, PVC, or PVDF for parts in contact with water.
 - D. Finish: Chromium plated.
 - E. Water Valves and Faucets: Provide units complying with ASME A112.18.1, with renewable seats, designed for working pressure up to 80 psig (550 kPa).
 - 1. Vacuum Breakers: Provide ASSE 1035 vacuum breakers on water fittings with serrated outlets.
 - 2. Aerators: Provide aerators on water fittings that do not have serrated outlets.

- F. Ball Valves: Chrome-plated ball and PTFE seals. Handle requires no more than 5 lbf (22 N) to operate. Provide units designed for working pressure up to 75 psig (520 kPa), with serrated outlets.
- G. Hand of Fittings: Furnish right-hand fittings unless fitting designation is followed by "L."
- H. Handles: Provide three- or four-arm, forged-brass handles for valves unless otherwise indicated.
 - 1. Provide lever-type handles for ground-key cocks. Lever handle aligns with outlet when valve is closed and is perpendicular to outlet when valve is fully open.
 - 2. Provide lever-type handles for ball valves unless otherwise indicated. Lever handle aligns with outlet when valve is closed and is perpendicular to outlet when valve is fully open.
 - 3. Provide knurled, molded-plastic handles for needle valves.
- I. Service-Outlet Identification: Provide color-coded plastic discs with embossed identification, secured to each service-fitting handle to be tamper resistant. Comply with SEFA 7 for colors and embossed identification.

PART 3 - EXECUTION

3.1 EXAMINATION

- A. Examine areas, with Installer present, for compliance with requirements for installation tolerances, location of reinforcements, and other conditions affecting performance of the Work.
- B. Proceed with installation only after unsatisfactory conditions have been corrected.

3.2 INSTALLATION OF CASEWORK

- A. Comply with installation requirements in SEFA 2. Install level, plumb, and true in line; shim as required using concealed shims. Where laboratory casework abuts other finished work, apply filler strips and scribe for accurate fit, with fasteners concealed where practical. Do not exceed the following tolerances:
 - 1. Variation of Tops of Base Cabinets from Level: 1/16 inch in 10 feet (1.5 mm in 3 m).
 - 2. Variation of Bottoms of Upper Cabinets from Level: 1/8 inch in 10 feet (3 mm in 3 m).
 - 3. Variation of Faces of Casework from a True Plane: 1/8 inch in 10 feet (3 mm in 3 m).
 - 4. Variation of Adjacent Surfaces from a True Plane (Lippage): 1/32 inch (0.8 mm).
 - 5. Variation in Alignment of Adjacent Door and Drawer Edges: 1/16 inch (1.5 mm).

3.3 INSTALLATION OF COUNTERTOPS

- A. Comply with installation requirements in SEFA 2. Abut top and edge surfaces true in plane with flush hairline joints and with internal supports placed to prevent deflection. Locate joints where indicated on Shop Drawings.

- B. Field Jointing: Where possible, make in same manner as shop-made joints, using dowels, splines, fasteners, adhesives, and sealants recommended by manufacturer. Shop prepare edges for field-made joints.
- C. Fastening:
 - 1. Secure countertops to cabinets with Z-type fasteners or equivalent, using two or more fasteners at each cabinet front, end, and back.
 - 2. Where necessary to penetrate countertops with fasteners, countersink heads approximately 1/8 inch (3 mm) and plug hole flush with material equal to countertop in chemical resistance, hardness, and appearance.
- D. Provide scribe moldings for closures at junctures of countertop, curb, and splash with walls as recommended by manufacturer for materials involved. Match materials and finish to adjacent laboratory casework. Use chemical-resistant, permanently elastic sealing compound where recommended by manufacturer.
- E. Dress joints smooth, remove surface scratches, and clean entire surface.

3.4 INSTALLATION OF LABORATORY ACCESSORIES

- A. Install accessories in accordance with Shop Drawings, installation requirements in SEFA 2, and manufacturer's written instructions.
- B. Install shelf standards plumb and at heights to align shelf brackets for level shelves. Install shelving level and straight, closely fitted to other work where indicated.

3.5 INSTALLATION OF SERVICE FITTINGS

- A. Comply with requirements in other Sections for installing water and laboratory gas service fittings and electrical devices.

- 3.6 Install fittings in accordance with Shop Drawings, installation requirements in SEFA 2, and manufacturer's written instructions. Set bases and flanges of sink- and countertop-mounted fittings in sealant recommended by manufacturer of sink or countertop material. Securely anchor fittings to laboratory casework unless otherwise indicated

3.7 CLEANING AND PROTECTING

- A. Clean finished surfaces, touch up as required, and remove or refinish damaged or soiled areas to match original factory finish, as approved by Architect.
- B. Protect countertop surfaces during construction with 6-mil (0.15-mm) plastic or other suitable water-resistant covering. Tape to underside of countertop at a minimum of 48 inches (1200 mm) o.c.

3.8 SERVICE-FITTING SCHEDULE

A. Water Service Fitting, Type: HWCW

1. Fitting Type: Swing-spout mixing faucet.
2. Outlet: Vacuum breaker and removable serrated outlet.
3. Mounting: Deck mounted.

B. Pure Water Service Fitting, Type: PW

1. Reference Standard: Water Saver L7853, Polypropylene-lined, deck-mounted
2. Fitting Type: Single Faucet, rigid gooseneck
3. Outlet: Removable Aerator and Vacuum breaker.
4. Mounting: Deck mounted.
5. Outlet: Female outlet with removable anti-splash serrated hose end
6. Handle: Wrist blade handle with color-coded index disc mounted on right side of outlet.

END OF SECTION 123553.19

SECTION 200500 – COMMON MECHANICAL WORK RESULTS

PART 1 - GENERAL

1.1 RELATED DOCUMENTS

- A. Drawings and general provisions of the Contract, including General and Supplementary Conditions and Division 1 Specification Sections, apply to this Section.

1.2 SUMMARY

- A. This Section includes the following:
 - 1. Basic Requirements Common to all Division(s) 20, 21, 22 and 23 Sections.
 - 2. Piping materials and installation instructions common to most piping systems.
 - 3. Sleeves.
 - 4. Escutcheons.
 - 5. Mechanical equipment and piping demolition.
 - 6. Equipment installation requirements common to equipment sections.
 - 7. Painting and finishing.
 - 8. Miscellaneous supports and anchorages.
- B. This section applies to all contractors performing work under Division(s) 20, 21, 22 and 23.

1.3 DEFINITIONS

- A. Finished Spaces: Spaces other than mechanical and electrical equipment rooms, furred spaces, pipe chases, unheated spaces immediately below roof, spaces above ceilings, unexcavated spaces, crawlspaces, and tunnels.
- B. Exposed, Interior Installations: Exposed to view indoors. Examples include finished occupied spaces and mechanical equipment rooms.
- C. Exposed, Exterior Installations: Exposed to view outdoors or subject to outdoor ambient temperatures and weather conditions. Examples include rooftop locations.
- D. Concealed, Interior Installations: Concealed from view and protected from physical contact by building occupants. Examples include above ceilings and in chases.
- E. Concealed, Exterior Installations: Concealed from view and protected from weather conditions and physical contact by building occupants but subject to outdoor ambient temperatures. Examples include installations within unheated shelters.
- F. Provide: Furnish and install the specific item, component, equipment, and/or system.
- G. Furnish: Supply the specific item, component, equipment, and/or system.

H. Install: Place in position and adjust for use the specific item, component, equipment, and/or system.

I. The following are industry abbreviations for plastic materials:

1. CPVC: Chlorinated polyvinyl chloride plastic.
2. PVC: Polyvinyl chloride plastic.

J. The following are industry abbreviations for rubber materials:

1. EPDM: Ethylene-propylene-diene terpolymer rubber.
2. NBR: Acrylonitrile-butadiene rubber.

1.4 SUBMITTAL REQUIREMENTS FOR DIVISION 20, 21, 22 and 23 SECTIONS

A. Product Data Submittals: Submit product data, including technical specifications, dimensional cut sheets, equipment computer selections, installation instructions, etc. for the following:

1. All materials and equipment.
2. Fire protection Systems.
3. Temperature control systems.

B. Reports and Systems Submittals: Provide reports, certificates, engineered systems drawings, etc. for the following:

1. Welding certificates.
2. Pipe and Duct Test Reports.
3. Ductwork Fabrication Drawings.
4. Fire Protection Sprinkler Drawings and Hydraulic Calculations.
5. Testing, Adjusting, and Balancing Reports.
6. Temperature Control System Drawings
7. Data, Reports, Certificates, Drawings, etc. as required by other Sections of the project specifications.

C. All submittals shall comply with the following:

1. Organized by specification sections and submitted complete for all manufactured items within the same specification section; partial submittals or submittals from multiple specification sections combined into a common submittal will not be permitted and will be returned un-reviewed or rejected.
2. Be submitted with the following information included:
 - a. Date submitted.
 - b. Project title and project number.
 - c. Name, address, and telephone number of the Contractor.
 - d. Name, address, and telephone number of the Architect.
 - e. Name, address, and telephone number of the Engineer.
 - f. Name, address, and telephone number of the supplier, manufacturer and/or subcontractor.
 - g. Number and title of the appropriate specification section.
 - h. Notification of deviations from the Contract Documents.
 - i. Contractor's stamp signed and dated by the contractor as required elsewhere in these specifications.

3. Be submitted with each item of equipment, component, etc., for review clearly marked and indicated where included with product data sheets.
4. Collated; where multiple cut sheets are submitted for the same components and multiple items are included in that section, the submittals shall be collated into the required number of sets of shop drawings as required in other sections of this specification.
5. Be drawn by competent draftspersons.
6. Be drawn in accordance with applicable Owner drawing standards when required under Divisions 0 or 1.

D. Engineer's Review:

1. The Engineer's review of submittals is for determining general compliance with the Contract Documents and is performed as a courtesy to the Contractor and as required by contractual obligation to the owner.
2. Corrections and comments made by the Engineer during review of submittals may not be all inclusive and do not relieve the contractor from full compliance with the Contract Documents. The Engineer reserves the right to re-review submittal information at any time and for any reason and to provide additional or supplemental comments at any time.
3. The contractor is solely responsible for determining all quantities and dimensions; selecting fabrication processes and techniques of construction; coordination of his work with the work of other trades, the owner, and existing conditions; performing all work in a safe and satisfactory manner.

- E. Contractor's Responsibility: Submittals are the sole responsibility of the Contractor. The Contractor is solely responsible for providing submittals demonstrating full compliance with the Contract Documents including completeness, accuracy, and coordination.

1.5 QUALITY ASSURANCE

A. Welding and Soldering

1. Welders Testing and Certification
 - a. All pipe fitters, plumbers, or other craftsmen must pass an ASME welding test and present proof of current ASME certification before doing any welding on this job. The Superintendent shall approve all welders.
2. Solderers Testing and Certification
 - a. All pipe fitters and plumbers must pass a soldering test given by Purdue before doing any soldering for this job.
3. Approval Period
 - a. Welders and solderers approved by the above tests shall be approved for a period not exceeding five years. After five years, or sooner, if welding or soldering appears to be below standards, the welder/solderer will be required to retake the test. If the ASME certification is used for approval, then a current certification must be presented for each job.
4. Identification Code

- a. When a welder or solderer has been approved, he will be given an identification code number or letter. For welds, this identification code must be stamped on all work welded by this welder. 1/4" stamp dies must be used at each weld. The markings are to be clear and deep in the pipe so that the welder/solderer can always be identified. For solder joints, the identification number shall be written on the pipe surface with permanent marker.
5. Improperly Identified Connections
 - a. Any weld not properly identified with a die stamped identification code number shall be removed and remade.
 6. Testing and Replacing Connections
 - a. When directed by the Owner's Representative the contractor will cut out sections of piping containing welds or solders for inspection and testing purposes. If a connection does not pass the Owner's approved standards, the Contractor will be required to replace the test section of piping at no additional cost to the Owner.
 - b. When a connection is found to be acceptable and meets the Owner's approved standards, the Owner will reimburse the Contractor for the replacement costs, and the Contractor will replace the test section of piping as directed by the Owner's Representative. All time and material cost slips must be signed by the Owner's Representative.]
- B. Piping Systems Testing Records:
1. Test each piping system indicated in individual piping Sections to be tested. Provide a signed and dated affidavit of testing to the Superintendent within 72 hours of completion of testing.
 2. Each affidavit shall contain, as a minimum, the date of the test, system or subsystem tested, test medium and pressure, duration of test, test results, name and signature of individual performing test, and the name and signature of witness to the test and whether the portion of pipe tested meets state and local regulations and Purdue requirements for leak testing. Copies of all affidavits shall be included in the Operation and Maintenance Manuals.
- C. Electrical Characteristics for Mechanical Equipment: Equipment of higher electrical characteristics may be furnished provided such proposed equipment is approved in writing and connecting electrical services, circuit breakers, fuses and conduit sizes are appropriately modified. If minimum energy ratings or efficiencies are specified, equipment shall comply with requirements. Contractor shall be responsible for costs associated with any upgrades to electrical power circuits and/or mechanical equipment resulting from electrical characteristics higher than those specified.
- 1.6 DELIVERY, STORAGE, AND HANDLING
- A. Deliver pipes and tubes with factory-applied end caps. Maintain end caps through shipping, storage, and handling to prevent pipe end damage and to prevent entrance of dirt, debris, and moisture.
 - B. Store plastic pipes protected from direct sunlight. Support to prevent sagging and bending.

- C. Provide for proper storage of all materials and equipment. Protect all materials and equipment from the elements, and store off of the ground. Rusted or weather damaged item(s) will not be permitted to be used, and replacement will be the contractor's responsibility.

1.7 COORDINATION

- A. The contractor shall be solely responsible for coordinating installation of new work with existing conditions. This coordination includes but is not limited to:
 - 1. Piping tie in points. Appropriate tie in points shall be identified in the field by the contractor, verifying that piping connected to is at least as large as shown herein. No extra costs will be allowed if a higher quantity of fittings, elbows etc. than what are shown herein are required to connect to the existing system.
 - 2. Ductwork tie in points. Appropriate tie in points shall be identified in the field by the contractor, verifying that ductwork connected to is at least as large as shown herein. No extra costs will be allowed if a higher quantity of fittings, elbows etc. than what are shown herein are required to connect to the existing system.
 - 3. Location of ductwork, piping, equipment etc.
 - 4. Piping and ductwork offsets and size transitions required to allow installation of new ductwork and piping. All offsets are not necessarily shown on plans. Where connections to equipment are different than shown on plans, it shall be the contractor's responsibility to make the appropriate transition to connect to the item being connected to.
 - 5. Cutting and patching of existing construction required to allow installation of new work. No extra costs will be allowed for cutting and patching required to install work shown herein.
 - 6. Removal and re-installation of existing ceiling(s) required to install work shown herein. No extra costs will be allowed for removal of existing ceiling(s) and/or re-installation of ceiling(s) as required to install the work herein. If existing ceilings are damaged during removal and are not suitable for re-installation, contractor shall be responsible to install new ceiling(s).
- B. The contractor shall be solely responsible for coordinating installation of new work with other trades. No extra costs will be allowed if it is necessary to remove and re-install new work already installed during the construction process to accommodate for a lack of coordination.
- C. Arrange for pipe spaces, chases, slots, and openings in building structure during progress of construction, to allow for mechanical installations.
- D. Coordinate installation of required supporting devices and set sleeves in poured-in-place concrete and other structural components as they are constructed.
- E. Access panels and doors for mechanical items in otherwise inaccessible spaces needing access (dampers, actuators, valves, water hammer arrestors, etc.) shall be provided. Coordinate requirements for access panels and doors for mechanical items requiring access that are concealed behind finished surfaces. Access panels and doors are specified elsewhere.
- F. Cooperate with other trades and coordinate locations and routings of mechanical piping, ductwork, valves, equipment and other mechanical items with all other trades.
- G. Installation shall allow easy access to valves, controls, dampers, etc. Installation shall allow adequate space for removal of coils, fans, heat exchangers, compressors, etc. Denial of acceptance of a given installation based on ease of access can be made by any of the following:

1. Owner.
2. Engineer.

1.8 REGULATORY AND CODE REQUIREMENTS:

- A. Secure and pay for all permits, fees, licenses and inspections for work performed under Division 20, 21, 22 and 23.
- B. Arrange and pay for inspections required by building inspection authorities.
- C. Comply with state and local code requirements and ordinances. Comply with requirements of the utility companies. Comply with industry standards. In the case of differences between the code requirements, ordinances, industry standards and this Specification, the most stringent shall govern. Code requirements, ordinances and industry standards shall increase but not diminish the requirements of this Specification.

1.9 TEMPORARY FACILITIES:

- A. Refer to Division 1.
- B. Temporary Heating and Cooling:
 1. Temporary heating or cooling will be provided by Division 1 Contractor.
 2. Use of the permanent heating, ventilating and air conditioning systems or any part thereof for temporary heating or cooling will not be allowed, unless written authorization has been obtained from the Owner for their use.
 3. If the permanent systems have been authorized for use, it shall be subject to the following requirements:
 - a. Building shall be enclosed and construction sufficiently complete.
 - b. Systems shall be completely and permanently installed as designed, including controls to permit safe operation as acceptable to the Mechanical Contractor.
 - c. Permanent wiring connections to permanent power sources shall be complete.
 - d. Once the heating systems have been placed in to operation, do not shut down except for moderate weather. Maintain minimum temperature of 50 deg. F in all parts of the building.
 - e. When air handling equipment is used, install and maintain temporary filters. Filter materials shall be in place over all return air openings, outside air openings and any openings where negative pressures are present in the duct system. Change filters and filter material when "build-up" of filtered dust substantially affects operation.
 - f. The Mechanical Contractor shall be solely responsible for the safe operation of the systems. The Mechanical Contractor shall be responsible for maintenance of the systems including personnel to monitor efficient use.
 - g. Just prior to Substantial Completion, provide maintenance and/or repairs required to place heating, ventilating and cooling system in "Like new" condition, including but not limited to the following:
 - 1) Cleaning of pipe, ductwork and equipment.
 - 2) Oiling and greasing of equipment or parts that would normally require same in a periodic maintenance program.

- 3) Replacement of all filters in air systems. This is over and above any extra set(s) of filters to be furnished to the Owner as called for in the Specifications. Filters shall be replaced prior to balancing of systems.
- 4) Replacement of significantly worn parts and parts that have been subject to unusual operating conditions.
- 5) Cleaning of pipeline water strainers.

h. The provisions of this article shall not in any way change or modify the requirements of the General Conditions concerning the warranty-guarantee period which follows Substantial Completion.

- 1) Contractor shall pay all costs, if any, to extend manufacturer's warranty on all items of equipment used for temporary facilities.
- 2) Where the permanent systems are used for temporary heating or cooling, the General Contractor shall be responsible for all costs.

1.10 SYSTEM STARTUP

- A. Comply with requirements of other product specific Sections.
- B. Perform tests on systems, equipment, etc., and clean systems, equipment, etc. as required by applicable codes and/or as specified herein.
- C. Provide additional belts and sheaves as required for proper adjustment of belt drive equipment.
- D. Verify that permanent power is correctly connected to components and that controls are complete and operational.
- E. Clean pipeline strainers and replace air and water filters so that clean filters and strainers have been provided to the owner.
- F. Clean surfaces of duct, pipe, equipment, etc.
- G. Provide full charge of oil, refrigerant, water, glycol, etc. as required to provide a complete and operational system.
- H. Operating Instructions
 1. Required: Submit three sets of operating and maintenance instructions and parts lists covering the items of equipment furnished. These instructions shall be furnished by the manufacturer of each item of equipment. The standard instructions shall be supplemented by such special instructions as may be necessary for the particular application of the equipment to this installation.
 2. Quality: Submit (3) typed and bound copies of Operating and Maintenance Manuals for approval prior to scheduling any system demonstration for the Owner. Data shall be suitably bound in hard covers with indexed sections and table of contents. Covers shall be labeled "Operating and Maintenance Instructions" with the name of the project, type of equipment covered and name of Contractor.
 3. Contents: The books shall contain, but not be limited to, the following general items; each item shall be provided with a separate index tab.

- a. Instructions (on Contractor's letterhead stationery) on who to call for service during guarantee period including name, address, and 24-hour telephone number of company responsible for servicing each piece of equipment or system.
 - b. Maintenance instructions (on Contractor's letterhead stationery) shall include the following.
 - 1) Preventative maintenance schedule for necessary cleaning, replacement and/or adjustment of all items such as belt drives, safety controls, oil and refrigerant charges.
 - 2) Cleaning schedule of all strainers, traps, coils, tubes, etc.
 - 3) Filter cleaning and/or replacement schedule, including size, quantity and interval.
 - c. Manufacturer's product data on each piece of equipment installed identified by drawing code numbers as they appear on the Drawing and in the Specifications. Data shall include the following.
 - 1) Installation instruction sheets.
 - 2) Spare parts lists.
 - 3) Operating manuals.
 - 4) Complete wiring diagrams.
 - d. All warranties provided by the manufacturer on their equipment that run longer than the one year warranty by the Contractor.
 - e. Valve chart(s) with schematic floor diagrams indicating valve locations with numbers labeled on valve chart.
 - f. All equipment start-up logs including certification of start-up by manufacturer.
 - g. All pipe pressure test certifications.
4. Final approval: Submission of these instructions by the contractor and approval of them by the Owner shall be a condition of final approval of the installation.
 5. Where other Section(s) of this specification are more stringent with regard to quantity of copies or information required, provide the more stringent requirement(s).

PART 2 - PRODUCTS

2.1 MANUFACTURERS

- A. In other Part 2 articles where subparagraph titles below introduce lists, the following requirements apply for product selection:
 1. Manufacturers: Subject to compliance with requirements, provide products by the manufacturers specified.

2.2 PIPE, TUBE, AND FITTINGS

- A. Refer to individual Division 20, 21, 22 and 23 piping Sections for pipe, tube, and fitting materials and joining methods.

- B. Pipe Threads: ASME B1.20.1 for factory-threaded pipe and pipe fittings.

2.3 JOINING MATERIALS

- A. Refer to individual Division 20, 21, 22 and 23 piping Sections for special joining materials not listed below.
- B. Pipe-Flange Gasket Materials: Suitable for chemical and thermal conditions of piping system contents.
 - 1. ASME B16.21, nonmetallic, flat, asbestos-free, 1/8-inch maximum thickness unless thickness or specific material is indicated.
 - a. Full-Face Type: For flat-face, Class 125, cast-iron and cast-bronze flanges.
 - b. Narrow-Face Type: For raised-face, Class 250, cast-iron and steel flanges.
 - 2. AWWA C110, rubber, flat face, 1/8 inch thick, unless otherwise indicated; and full-face or ring type, unless otherwise indicated.
- C. Flange Bolts and Nuts: ASME B18.2.1, carbon steel, unless otherwise indicated.
- D. Plastic, Pipe-Flange Gasket, Bolts, and Nuts: Type and material recommended by piping system manufacturer, unless otherwise indicated.
- E. Solder Filler Metals: ASTM B 32, lead-free alloys. Include water-flushable flux according to ASTM B 813. Solder and flux materials for use on domestic water systems shall contain not more than 0.2 percent lead.
- F. Brazing Filler Metals: AWS A5.8, BCuP Series, copper-phosphorus alloys for general-duty brazing, unless otherwise indicated; and AWS A5.8, BAg1, silver alloy for refrigerant piping, unless otherwise indicated.
- G. Welding Filler Metals: Comply with AWS D10.12 for welding materials appropriate for wall thickness and chemical analysis of steel pipe being welded.
- H. Solvent Cements for Joining CPVC Plastic Piping: ASTM F 493.

2.4 SLEEVES

- A. Steel Pipe: ASTM A 53, Type E, Grade B, Schedule 40, galvanized, plain ends.
- B. Cast Iron: Cast or fabricated "wall pipe" equivalent to ductile-iron pressure pipe, with plain ends and integral waterstop, unless otherwise indicated.

2.5 DIELECTRIC NIPPLES

- A. Electroplated steel nipple with inert and noncorrosive, thermoplastic lining; plain, threaded, or grooved ends; and 300 psig minimum working pressure at 225 deg F.
- B. Manufacturers:

1. Perfection Corp.
2. Grinnell Gruvlok
3. Victaulic Co. of America.

2.6 DIELECTRIC FLANGES

- A. Galvanized or plated steel threaded end, copper solder end and gasket to isolate dissimilar metals.
- B. Gasket shall be suitable for the application.
- C. Flanges shall be complete with insulated bolt sleeves, washers and gaskets.
- D. Flanges shall be rated for 175 PSI.
- E. Manufacturers:
 1. Watts.

2.7 ESCUTCHEONS

- A. Description: Manufactured wall and ceiling escutcheons and floor plates, with an ID to closely fit around pipe, tube, and insulation of insulated piping and an OD that completely covers opening.
- B. One-Piece, Deep-Pattern Type: Deep-drawn, box-shaped brass with polished chrome-plated finish.
- C. One-Piece, Cast-Brass Type: With set screw.
 1. Finish: Polished chrome-plated.
- D. Split-Casting, Cast-Brass Type: With concealed hinge and set screw.
 1. Finish: Polished chrome-plated.
- E. One-Piece, Stamped-Steel Type: With set screw and chrome-plated finish.
- F. Split-Plate, Stamped-Steel Type: With concealed hinge, set screw, and chrome-plated finish.
- G. One-Piece, Floor-Plate Type: Cast-iron floor plate.
- H. Split-Casting, Floor-Plate Type: Cast brass with concealed hinge and set screw.

2.8 GROUT

- A. Description: ASTM C 1107, Grade B, nonshrink and nonmetallic, dry hydraulic-cement grout.
 1. Characteristics: Post-hardening, volume-adjusting, nonstaining, noncorrosive, nongaseous, and recommended for interior and exterior applications.

2. Design Mix: 5000-psi, 28-day compressive strength.
3. Packaging: Premixed and factory packaged.

2.9 ROOF CURBS

- A. Description: Heavy gauge galvanized steel, utilized, full mitered corners, all seams welded, 1-1/2" thick rigid fiberglass insulation, pressure treated wood nailer strip.
- B. Provide roof curbs installed with waterproof galvanized steel cap for ductwork roof penetrations. Flash and counter flash penetrations. See architectural curb details.
- C. Provide minimum 16" high curb.

PART 3 - EXECUTION

3.1 GENERAL

- A. Install mechanical and plumbing items in accordance with the manufacturer's written instructions, and in accordance with these Specifications. If there is a discrepancy between the two, the more stringent requirement shall govern the installation requirements.

3.2 MECHANICAL DEMOLITION

- A. Refer to Division 1 for general demolition requirements and procedures.
- B. Disconnect, demolish, and remove mechanical systems, equipment, and components indicated to be removed. This includes removal of hangers, valves, dampers, actuators, etc. which are installed as part of the work indicated to be removed.
 1. Piping to Be Removed: Remove portion of piping indicated to be removed and cap or plug remaining piping with same or compatible piping material.
 2. Piping to Be Abandoned in Place: Drain piping and cap or plug piping with same or compatible piping material.
 3. Ductwork to Be Removed: Remove portion of ductwork indicated to be removed and cap and seal remaining ductwork with same or material.
 4. Equipment to Be Removed: Disconnect and cap services and remove equipment.
 5. Equipment to Be Removed and Reinstalled: Disconnect and cap services and remove, clean, and store equipment; when appropriate, reinstall, reconnect, and make equipment operational.
 6. Equipment to Be Removed and Salvaged: Disconnect and cap services and remove equipment and deliver to Owner.
- C. If pipe, ductwork, insulation, or equipment to remain is damaged in appearance or is unserviceable, remove damaged or unserviceable portions and replace with new products of equal capacity and quality.
- D. Where areas of the project will remain occupied during this project, coordinate required interruption of mechanical, plumbing and/or fire protection service to those areas which are

necessary for the contractor to perform the work specified herein with the owner at least 10 days prior to the required interruption.

- E. Equipment Removal: All equipment such as lab equipment, air handling units, exhaust fans, radiation, grilles, registers, diffusers, etc., shall become the property of the Contractor and shall be removed from the premises and be disposed of properly. Reuse of any equipment and/or material shall be indicated on the Drawings or as approved by the Engineer.
- F. Patching of Openings: Where existing pipe, ducts, etc. are removed, patch openings with construction similar to existing, flush with existing surfaces, and smooth as required to receive new finishes.
- G. Occupant Protection: Provide protection for building occupants and furnishings against smoke, dust and damage during demolition operations in all occupied areas. Seal all open ducts to remain with plastic sheet and seal any other penetrations to the occupied space.
- H. Maintain the project area under negative pressure with a portable filtered exhaust fan during construction. Contact Kevin Thedans at 765-496-1937 for the availability of university-owned units.

3.3 PIPING SYSTEMS - COMMON REQUIREMENTS

- A. Install piping according to the following requirements and Division 20, 21, 22 and 23 Sections specifying piping systems.
- B. Drawing plans, schematics, and diagrams indicate general location and arrangement of piping systems. Indicated locations and arrangements were used to size pipe and calculate friction loss, expansion, pump sizing, and other design considerations. Install piping as indicated unless deviations to layout are approved on Coordination Drawings.
- C. Install piping and ductwork in concealed locations, unless otherwise indicated and except in equipment rooms and service areas.
- D. Install piping and ductwork at right angles to or parallel to building walls. Diagonal runs are prohibited unless specifically indicated otherwise.
- E. Install work above accessible ceilings to allow sufficient space for ceiling panel removal.
- F. Install piping to permit valve servicing.
- G. Install piping at indicated slopes.
- H. Install piping free of sags and bends.
- I. Install fittings for changes in direction and branch connections.
- J. Install piping to allow application of insulation.
- K. Select system components with pressure rating equal to or greater than system operating pressure.
- L. Install escutcheons for penetrations of walls, ceilings, and floors according to the following:

1. New Piping:
 - a. Piping with Fitting or Sleeve Protruding from Wall: One-piece, deep-pattern type.
 - b. Chrome-Plated Piping: One-piece, cast-brass type with polished chrome-plated finish.
 - c. Insulated Piping: One-piece, stamped-steel type with spring clips.
 - d. Bare Piping at Wall and Floor Penetrations in Finished Spaces: One-piece, cast-brass type with polished chrome-plated finish.
 - e. Bare Piping at Ceiling Penetrations in Finished Spaces: One-piece, cast-brass type with polished chrome-plated finish.
 - f. Bare Piping in Unfinished Service Spaces: One-piece, cast-brass type with polished chrome-plated finish.
 - g. Bare Piping in Equipment Rooms: One-piece, cast-brass type.
 - h. Bare Piping at Floor Penetrations in Equipment Rooms: One-piece, floor-plate type.
 2. Existing Piping: Use the following:
 - a. Chrome-Plated Piping: Split-casting, cast-brass type with chrome-plated finish.
 - b. Insulated Piping: Split-plate, stamped-steel type with concealed hinge and spring clips.
 - c. Bare Piping at Wall and Floor Penetrations in Finished Spaces: Split-casting, cast-brass type with chrome-plated finish.
 - d. Bare Piping at Ceiling Penetrations in Finished Spaces: Split-casting, cast-brass type with chrome-plated finish.
 - e. Bare Piping in Unfinished Service Spaces: Split-casting, cast-brass type with polished chrome-plated finish.
 - f. Bare Piping in Equipment Rooms: Split-casting, cast-brass type.
 - g. Bare Piping at Floor Penetrations in Equipment Rooms: Split-casting, floor-plate type.
- M. Install sleeves for pipes passing through concrete and masonry walls, and for pipes passing through floor and roof slabs.
1. Cut sleeves to length for mounting flush with both surfaces.
 2. Install sleeves that are large enough to provide 1/4-inch annular clear space between sleeve and pipe or pipe insulation. Use the following sleeve materials:
 - a. Steel Pipe Sleeves: For pipes smaller than NPS 6.
 - 1) Seal space outside of sleeve fittings with grout.
 3. Except for underground wall penetrations, seal annular space between sleeve and pipe or pipe insulation, using joint sealants appropriate for size, depth, and location of joint. Refer to Division 7 for materials and installation.
- N. Fire-Barrier Penetrations: Maintain indicated fire rating of walls, partitions, ceilings, and floors at pipe penetrations. Seal pipe penetrations with firestop materials. Refer to Division 7 Section "Through-Penetration Firestop Systems" for materials.
- O. Pipes penetrating gypsum board or plaster partitions: In locations where gypsum board or plaster partitions extend to the underside of the deck above, seal annular space between partition and pipe or pipe insulation penetration with sealant materials as specified in Division 7.

- P. Verify final equipment locations for roughing-in.
- Q. Refer to equipment specifications in other Sections of these Specifications for roughing-in requirements.

3.4 PLACEMENT OF PIPES, DUCTS, EQUIPMENT ETC.

- A. Headroom: All possible headroom shall be maintained under exposed piping and ductwork. A minimum of 7 feet headroom shall be maintained in mechanical spaces, unless otherwise shown or specified.
- B. Ease of Service: Install all work to permit removal of coils, heat exchanger bundles, fan shafts and wheels, filters, belt guards, sheaves and drives, and all other parts which require periodic replacement or maintenance. Arrange pipes, ducts and equipment to permit ready access to valves, traps, starters, motors, control components. Allow sufficient clearance to allow complete opening of doors and of access panels.
- C. Conceal All Piping: Conceal all piping in finished areas of the building except where otherwise noted on the Drawings.
- D. Work in Rooms with Suspended Ceilings: Keep the piping and ductwork above recessed light fixtures and ceiling channels so the room ceiling height can be maintained.
- E. Work in Rooms without Suspended Ceilings: All mechanical work shall be kept above the light fixtures. Verify the light fixture height with the Electrical Contractor and the Electrical Plans. If it is impossible to maintain the required heights, written approval from the Architect shall be obtained before installing any work.
- F. Work in Rooms Outside Project Area: Where piping and/or ductwork extends through existing rooms, the work shall be kept above existing ceiling and/or light fixtures. If it is impossible to maintain the required heights, written approval of the Architect shall be obtained before installing any work.
- G. Anchors, Chases, Recesses, etc.: Properly locate anchors, chases, recesses and openings required for the proper installation of the work. Arrange work with the proper Contractors for required chases, recesses and openings, including required space for fire dampers and sleeves.

3.5 MECHANICAL EQUIPMENT RIGGING

- A. All equipment and devices to be removed and installed shall be lifted in place. Provide temporary supports, ramps, hoists, etc. as required to safely and completely remove existing equipment and devices. Install new equipment and devices as indicated on Drawings.
- B. Visit the project site prior to submitting bid and become thoroughly familiar with existing building conditions.
- C. Provide protection for existing structures and be responsible for repairing or replacing, to the Owner's satisfaction, any damaged structures resulting from negligence by this Contractor in the performance of the work.

- D. Upon completion of the work, all temporary supports, ramps, hoists, etc. shall be dismantled and removed from the job site. Repair any marred or damaged building structures and surfaces to the Owner's satisfaction which are a result of installation of temporary supports, ramps, hoists, etc.
- E. In all cases, fully comply with manufacturer's written instructions for the rigging, unloading, and transporting of equipment.

3.6 PIPING JOINT CONSTRUCTION

- A. Join pipe and fittings according to the following requirements and Division 20, 21, 22 and 23 Sections specifying piping systems.
- B. Ream ends of pipes and tubes and remove burrs. Bevel plain ends of steel pipe.
- C. Remove scale, slag, dirt, and debris from inside and outside of pipe and fittings before assembly.
- D. Soldered Joints: Apply ASTM B 813, water-flushable flux, unless otherwise indicated, to tube end. Construct joints according to ASTM B 828 or CDA's "Copper Tube Handbook," using lead-free solder alloy complying with ASTM B 32.
- E. Brazed Joints: Construct joints according to AWS's "Brazing Handbook," "Pipe and Tube" Chapter, using copper-phosphorus brazing filler metal complying with AWS A5.8.
- F. Threaded Joints: Thread pipe with tapered pipe threads according to ASME B1.20.1. Cut threads full and clean using sharp dies. Ream threaded pipe ends to remove burrs and restore full ID. Join pipe fittings and valves as follows:
 - 1. Apply appropriate tape or thread compound to external pipe threads unless dry seal threading is specified.
 - 2. Damaged Threads: Do not use pipe or pipe fittings with threads that are corroded or damaged. Do not use pipe sections that have cracked or open welds.
- G. Welded Joints: Construct joints according to AWS D10.12, using qualified processes and welding operators according to Part 1 "Quality Assurance" Article.
- H. Flanged Joints: Select appropriate gasket material, size, type, and thickness for service application. Install gasket concentrically positioned. Use suitable lubricants on bolt threads.
- I. Plastic Piping Solvent-Cement Joints: Clean and dry joining surfaces. Join pipe and fittings according to the following:
 - 1. Comply with ASTM F 402 for safe-handling practice of cleaners, primers, and solvent cements.
 - 2. CPVC Piping: Join according to ASTM D 2846/D 2846M Appendix.
- J. Plastic Pressure Piping Gasketed Joints: Join according to ASTM D 3139.

3.7 PIPING CONNECTIONS

- A. Make connections according to the following, unless otherwise indicated:
 - 1. Install unions in piping NPS 2 and smaller adjacent to each automatic control valve, at final connection to each piece of equipment, and/or where shown on drawings.
 - 2. Install flanges in piping NPS2-1/2 and larger adjacent to valves, at each piece of equipment, and/or where shown on drawings.
 - 3. Install dielectric fittings to connect piping materials of dissimilar metals. Dielectric flanges are only allowed in mechanical equipment rooms. Provide dielectric nipples in other locations. Brass is not considered an adequate isolator between copper and steel.

3.8 PAINTING

- A. Damage and Touchup: Repair marred and damaged factory-painted finishes with materials and procedures to match original factory finish.
- B. Refer to Division 20 Section "Mechanical Identification" for additional Painting Requirements.

3.9 ERECTION OF METAL SUPPORTS AND ANCHORAGES

- A. Refer to Division 5 Section "Metal Fabrications" for structural steel.
- B. Cut, fit, and place miscellaneous metal supports accurately in location, alignment, and elevation to support and anchor mechanical materials and equipment.
- C. Field Welding: Comply with AWS D1.1.

END OF SECTION 200500

SECTION 200503 – BASIC PIPING MATERIALS AND METHODS

PART 1 – GENERAL

1.1 RELATED DOCUMENTS

- A. Drawings and general provisions of the Contract, including General and Supplementary Conditions and Division 1 Specification Sections, apply to this Section.

1.2 SUMMARY

- A. This Section applies to Piping and Piping Systems specified in Division(s) 20, 21, 22 and 23.

1.3 SYSTEM DESCRIPTION

- A. Installation and Testing: Install all new piping as indicated on the Plans and as described in the following paragraphs. All tests must be done to the satisfaction of the Owner's Representative and local authorities having jurisdiction, before covering. Properly notify the Owner's Representative and local authorities before the work is tested. Furnish all instruments required for testing. Test piping and ductwork systems prior to concealment. Ensure that the test pressure which might damage fixtures or equipment does not reach such units by valving them off or otherwise isolating them during the test. Furnish all plugs, piping, valves, hoses and pumps necessary for the required tests and for proper disposal of the water upon completion of the tests.
- B. Piping Covered in This Section: This section of the Specifications covers the furnishing and installation of all pipe and pipe fittings except buried water and fire service mains, sewers, and special piping systems as specified elsewhere.
- C. Pipe Size:
 - 1. No piping except control air piping shall be smaller than 3/4" with the following exceptions.
 - a. Water piping to a single sink, lavatory, etc., as indicated on the Drawings and as specified herein.
 - b. Piping as reduced for connection to apparatus.
 - 2. All piping shall be run full size as indicated on the Drawings and as specified herein. Any reduction in size required by equipment connections shall be made at the connection point. All valves, strainers, etc., shall be the pipe size noted on the Drawings and as specified herein.

- D. Completeness of Work: The piping systems shall be installed complete and shall include connections to all items or pieces of equipment including items which may be furnished by others such as laboratory equipment, kitchen equipment, equipment furnished by Owner, etc.

PART 2 – PRODUCTS

NOT USED

PART 3 – EXECUTION

3.1 PIPE INSTALLATION

- A. Cleaning of Pipe: All piping shall be clean and free of scale and dirt, including steel pipe which shall be stood on end and hammered prior to installation. All piping shall be reamed after cutting. Threaded and grooved pipe shall be cleaned of chips and oil with a non-flammable solvent.
- B. Cold Springing: Install piping without springing or forcing except when cold springing is specified.
- C. Clearance: Provide clearance for proper installation of insulation and for access to valves, air vents, drains, unions, etc. Provide minimum 1" clearance between pipes after insulation.
- D. Changes of Direction And Tees: Make changes in direction and sizes with fittings. Use tees for branch lines except Weld-O-Lets and Thread-O-Lets which may be used on welded installations. Use long radius fittings wherever possible. Mechanically formed copper tee connections are acceptable where specified in individual Sections. Mechanical outlet couplings are not allowed.
- E. Running of Pipe: Route piping in locations indicated in an orderly manner and maintain required grades. Coordinate with other piping, ducts, conduits and equipment, making offsets as required to accommodate same. All piping shall be run parallel or perpendicular to walls, ceilings, etc. in a neat workmanlike manner. Any 'stiff' connections shown on the Plans shall be considered as diagrammatic only, as lateral offsets are required in any piping where expansion will occur. Install vertical piping plumb and straight; horizontal piping parallel with walls and partitions. Conceal piping in finished areas, unless otherwise indicated.
- F. Headroom: Install piping to conserve headroom and interfere as little as possible with use of available space. Group piping parallel to each other and at common elevations wherever possible. Install concealed piping close to the building structure to keep furring to a minimum. Clear windows, doors and other openings.

3.2 PRESSURE TESTING OF PIPE

- A. Leak Testing: All piping shall be leak tested for leaks and prove to be leak free using the following methods.

Table 1 – Pipe Leak Testing		
Type of Pipe	Pressure Requirement	Duration
Hydronic Heating Water	125 psig hydrostatic	6 Hours
Interior domestic water	125 psig hydrostatic	6 Hours
Drain, waste, and storm drain	Standing water 10 feet of head	1 Hour
Fire Lines	200 psig hydrostatic	6 Hours

- B. Testing Procedure: All hydrostatic pressure tests to be held for a minimum of six (6) hours without loss of pressure. All hydrostatic gravity tests shall be held long enough to visually inspect each joint with no visible loss of water for 15 minutes. Air tests to be held for a minimum of two (2) hours without loss of pressure. Any visible leakage or appreciable pressure drop during the test will be cause for rejecting the test. Additional tests will be required after corrective measures have been taken until satisfactory results are obtained.
- C. Testing Records: A signed and dated affidavit of testing shall be provided to the Owner's Representative within 72 hours of completion of testing. Each affidavit shall contain, as a minimum, the date of the test, system or subsystem tested, test medium and pressure, duration of test, test results, name and signature of individual performing test, and the name and signature of witness to the test and whether the portion of pipe tested meets state and local regulations and Purdue requirements for leak testing. Copies of all affidavits shall be included in the Operation and Maintenance Manuals.

3.3 CLEANING OF PIPE

A. Potable Water:

1. Hydraulically flush the entire system to remove construction debris.
2. Sterilization as outlined in Section 221116 for potable water.

B. Non-Potable Water:

1. Hydraulically flush the entire system to remove construction debris.
2. Sterilization as outlined in Section 221116 for non-potable water.

C. Hydronic Heating Water:

1. Hydraulically flush the entire system with potable water through an approved backflow prevention device to remove construction debris.
2. Refer to Division 232113 Section "Hydronic Piping" for additional requirements.

3.4 PIPE JOINTS

A. Threading of Pipe: Threading of pipe shall conform to ANSI B2.1. Threads shall be clean and sharp and of accurate gauge.

B. Joint Compounds and Tape: Teflon tape shall be applied to only the male threads. Provide Teflon tape on water piping threaded joints. Joint compound is not allowed on water piping. Teflon tape is not to be used on gas piping.

C. Caulking: Caulking of threaded joints to stop leaks is not allowed.

END OF SECTION 200503

SECTION 200504 – LABORATORY GENERAL PIPING AND EQUIPMENT

PART 1 - GENERAL

1.1 RELATED DOCUMENTS

- A. Drawings and general provisions of the Contract, including General and Supplementary Conditions and Division 1 Specification Sections, apply to this Section.

1.2 SUMMARY

- A. This section applies to all contractors performing work under Division 20, 22 and 23.

1.3 DEFINITIONS

- A. Laboratory Equipment: Casework, fume hoods, etc. provided and specified as part of Division 12.

1.4 GENERAL REQUIREMENTS

- A. Furnish and install laboratory equipment plumbing, piping, rough-ins, valves, fittings, traps, etc., and make plumbing connections to the laboratory equipment.
- B. Service outlets and faucets located in or on laboratory equipment shall be furnished as part of Division 12 work. Division 22 contractor shall install non electrical service outlets as shown on the Drawings and in accordance with the laboratory equipment shop drawings. Fume hood remote control valves and outlets will be factory installed.
- C. Piping shall be provided in or on equipment in accordance with detail plans and shop drawings furnished as part of the laboratory equipment shop drawings. Service piping in fume hoods shall be provided by Division 22 contractor.
- D. Division 12 contractor will furnish plumbing items and sinks, and will issue the plumbing items and sinks to the Division 22 contractor. Protect these items from damage until final completion of the project. Division 22 Contractor shall be responsible for costs required to repair or replace items lost or damaged after having been issued these items.
- E. Sinks, strainers, tailpieces, service outlets (air, CO2, vac, etc.), cold water faucets, hot water faucets, mixing faucets, remote control valves and outlets, etc., shown or required on or in laboratory equipment will be furnished as part of Division 12, and installed by Division 22 contractor. Division 22 contractor shall furnish and install other plumbing items and material necessary to make a complete installation. Laboratory vacuum outlets shall be furnished by Division 22 contractor. Refer to Division 22 Section "Laboratory Vacuum Systems".
- F. Service outlets, faucets, mixing faucets, valves, etc., shown or required surface mounted on the wall or on Unistrut racks shall be provided by Division 22 contractor.

- G. Provide shutoff valves in branch piping to each laboratory room, at final connections to equipment and where shown on Drawings.
- H. Provide hangers and support piping from supports furnished by the laboratory equipment supplier in the equipment pipe chase or on wall mounted metal framing system equal to Unistrut. Division 22 contractor shall provide metal framing system, unless otherwise noted.
- I. Piping routed through laboratory casework shall be run undiminished in size unless otherwise indicated.
- J. Insulate piping as required in Division 20 Section "Mechanical Insulation".
- K. Chemical wastes, vents and traps shall be as specified in Division 22 Section "Chemical Resistant Waste and Vent Piping".
- L. The laboratory equipment supplier will furnish holes in table tops, shelves, curbs, etc., for piping.
- M. Prior to connecting hot and cold water to fume hood outlets, verify that vacuum breakers are installed, exterior to the fume hood.
- N. Refer to the architectural sheets for equipment locations, elevations, components, etc. provided and or furnished as part of Division 12.

1.5 REQUIREMENTS FOR LABORATORY SINKS:

- A. Division 22 Contractor shall install sinks and cup sinks that are not integral with countertop. Install sinks per laboratory equipment manufacturer's installation instructions.
- B. Division 22 Contractor shall furnish and install sealant between countertop and epoxy resin sinks and cup sinks.
- C. Division 22 Contractor shall install strainers, tailpieces and overflows.
- D. Division 22 Contractor shall furnish and install P-traps and supply stops for sinks and cup sinks. Sink outlets shall be 1-1/2" with strainers unless otherwise noted. Provide adapters and transition pieces as required to connect to tailpieces furnished by equipment supplier. Provide tailpieces for sinks not furnished with such.
- E. Chemical wastes, vents and traps shall be as specified in Division 22 Section "Chemical Resistant Waste and Vent Piping".

PART 2 - PRODUCTS (Not Used)

PART 3 - EXECUTION (Not Used)

END OF SECTION 200504

SECTION 200519 – THERMOMETERS AND GAUGES

PART 1 - GENERAL

1.1 RELATED DOCUMENTS

- A. Drawings and general provisions of the Contract, including General and Supplementary Conditions and Division 1 Specification Sections, apply to this Section.

1.2 SUMMARY

- A. Section Includes:

- 1. Test plugs.

- B. This Section applies to Test Plugs, etc. provided for systems that are specified in Division(s) 20, 21, 22 and 23.

- C. Related Sections:

1.3 DEFINITIONS

- A. CR: Chlorosulfonated polyethylene synthetic rubber.
- B. EPDM: Ethylene-propylene-diene terpolymer rubber.

1.4 SUBMITTALS

- A. Product Data: For each type of product indicated; include performance curves.

PART 2 - PRODUCTS

2.1 TEST PLUGS

- A. Manufacturers: Subject to compliance with requirements, [provide products by one of the following] [available manufacturers offering products that may be incorporated into the Work include, but are not limited to, the following]:
 - 1. Flow Design, Inc.
 - 2. MG Piping Products Co.
 - 3. National Meter, Inc.

4. Peterson Equipment Co., Inc.
 5. Sisco Manufacturing Co.
 6. Trerice, H. O. Co.
 7. Watts Industries, Inc.; Water Products Div.
- B. Description: Corrosion-resistant brass or stainless-steel body with core inserts and gasketed and threaded cap, with extended stem for units to be installed in insulated piping.
- C. Minimum Pressure and Temperature Rating: **500 psig at 200 deg F.**
- D. Core Inserts: One or two self-sealing rubber valves.
1. Insert material for water service at **20 to 200 deg F** shall be CR.
 2. Insert material for water service at **minus 30 to plus 275 deg F** shall be EPDM.

PART 3 - EXECUTION

3.1 INSTALLATIONS

- A. Pressure-Temperature Taps:
1. Install test plugs in tees in piping.
 2. Provide pressure-temperature taps at the following locations:
 - a. At the inlet and outlet of each piece of hydronic equipment where a change of pressure takes place (excluding radiation).
 - b. Where required for testing, adjusting and balancing.
 - c. Elsewhere as shown on the Drawings.
 3. Install taps immediately before and after equipment with no valve or fitting between the tap and the equipment.
 4. Install taps so that they are accessible for insertion of thermometers and gauges.

END OF SECTION 200519

SECTION 200523 - GENERAL-DUTY VALVES

PART 1 - GENERAL

1.1 RELATED DOCUMENTS

- A. Drawings and general provisions of the Contract, including General and Supplementary Conditions and Division 1 Specification Sections, apply to this Section.

1.2 SUMMARY

- A. Section Includes:

1. Ball valves.
2. Lug type butterfly valves.
3. Grooved end butterfly valves.
4. Bronze swing check valves.
5. Iron swing check valves.
6. Iron, grooved-end swing check valves.
7. Bronze gate valves.
8. Iron gate valves.
9. Bronze globe valves.
10. Iron globe valves.

- B. This Section includes General-Duty Valves provided for use in systems specified in Division 20, 21, 22 and 23.

- C. Related Sections:

1. Division 20, 21, 22 and 23 piping Sections for specialty valves applicable to those Sections only.
2. Division 20 Section "Mechanical Identification and Painting" for valve tags and schedules.
3. Division 23 Section "HVAC Instrumentation and Controls" for control valves and actuators.

1.3 DEFINITIONS

- A. CWP: Cold working pressure.
- B. EPDM: Ethylene propylene copolymer rubber.
- C. NBR: Acrylonitrile-butadiene, Buna-N, or nitrile rubber.

- D. NRS: Nonrising stem.
- E. OS&Y: Outside screw and yoke.
- F. RS: Rising stem.
- G. SWP: Steam working pressure.

1.4 SUBMITTALS

- A. Product Data: For each type of valve indicated. Include body, seating, and trim materials; valve design; pressure and temperature classifications; end connections; arrangement; dimensions; and require clearances. Include list indicating valve and its application. Include rated capacities; furnished specialties; and accessories.

1.5 QUALITY ASSURANCE

- A. Source Limitations for Valves: Obtain each type of valve from single source from single manufacturer.
- B. ASME Compliance:
 - 1. ASME B16.10 and ASME B16.34 for ferrous valve dimensions and design criteria.
 - 2. ASME B31.1 for power piping valves.
 - 3. ASME B31.9 for building services piping valves.
- C. NSF Compliance: NSF 61 for valve materials for potable-water service.
- D. Valves installed in domestic water piping systems shall comply with The Reduction of Lead in Drinking Water Act and be certified Lead Free, with a weighted average of less than 0.25 percent lead content, in accordance with the requirements of this Law which will be in effect as of January 4, 2014.

1.6 DELIVERY, STORAGE, AND HANDLING

- A. Prepare valves for shipping as follows:
 - 1. Protect internal parts against rust and corrosion.
 - 2. Protect threads, flange faces, grooves, and weld ends.
 - 3. Set angle, gate, and globe valves closed to prevent rattling.
 - 4. Set ball and plug valves open to minimize exposure of functional surfaces.
 - 5. Set butterfly valves closed or slightly open.
 - 6. Block check valves in either closed or open position.
- B. Use the following precautions during storage:

1. Maintain valve end protection.
 2. Store valves indoors and maintain at higher than ambient dew point temperature. If outdoor storage is necessary, store valves off the ground in watertight enclosures.
- C. Use sling to handle large valves; rig sling to avoid damage to exposed parts. Do not use handwheels or stems as lifting or rigging points.

PART 2 - PRODUCTS

2.1 GENERAL REQUIREMENTS FOR VALVES

- A. Refer to Part 3 "Valve Applications" for applications of valves.
- B. Valve Pressure and Temperature Ratings: Not less than indicated and as required for system pressures and temperatures.
- C. Valve Sizes: Same as upstream piping unless otherwise indicated.
- D. Valve Actuator Types:
1. Gear Actuator: For quarter-turn valves **NPS 8** and larger.
 2. Handwheel: For valves other than quarter-turn types.
 3. Handlever: For quarter-turn valves **NPS 6** and smaller.
 4. Wrench: For plug valves with square heads. Furnish Owner with 1 wrench for every 5 plug valves, for each size square plug-valve head.
 5. Chainwheel: Device for attachment to valve handwheel, stem, or other actuator; of size and with chain for mounting height, as indicated in the "Valve Installation" Article.
- E. Valves in Insulated Piping: With **2-inch** stem extensions and the following features:
1. Gate Valves: With rising stem.
 2. Ball Valves: With extended operating handle of non-thermal-conductive material, and protective sleeve that allows operation of valve without breaking the vapor seal or disturbing insulation.
 3. Butterfly Valves: With extended neck.
- F. Valve-End Connections:
1. Flanged: With flanges according to ASME B16.1 for iron valves.
 2. Grooved: With grooves according to AWWA C606.
 3. Threaded: With threads according to ASME B1.20.1.
- G. Valve Bypass and Drain Connections: MSS SP-45.

2.2 BALL VALVES

A. Two-Piece, Full-Port, Bronze Ball Valves with Bronze Trim:

1. Manufacturers: Subject to compliance with requirements, provide products by one of the following:
 - a. Conbraco Industries, Inc.; Apollo Valves.
 - b. Crane Co.; Crane Valve Group; Crane Valves.
 - c. Hammond Valve.
 - d. Milwaukee Valve Company.
 - e. NIBCO INC.
 - f. Watts Regulator Co.; a division of Watts Water Technologies, Inc.
 - g. Nexus.
 - h. Grinnell.
 - i. Victaulic.
2. Description:
 - a. Standard: MSS SP-110.
 - b. SWP Rating: 150 psig.
 - c. CWP Rating: 600 psig.
 - d. Body Design: Two piece.
 - e. Body Material: Bronze.
 - f. Ends: Threaded.
 - g. Seats: PTFE or TFE.
 - h. Stem: Bronze.
 - i. Ball: Chrome-plated brass.
 - j. Port: Full.
 - k. Shall be dezincification resistant.

2.3 LUG TYPE BUTTERFLY VALVES

A. 200 CWP, Iron, Single-Flange Butterfly Valves with EPDM Seat and Aluminum-Bronze Disc:

1. Manufacturers: Subject to compliance with requirements, provide products by one of the following:
 - a. Grinnell.
 - b. Hammond Valve.
 - c. Milwaukee Valve Company.
 - d. NIBCO INC.
 - e. Mueller Steam Specialty.
 - f. Watts Regulator Co.; a division of Watts Water Technologies, Inc.
2. Description:
 - a. Standard: MSS SP-67, Type I.

- b. CWP Rating: **200 psig**.
- c. Body Design: Lug type; suitable for bidirectional dead-end service at rated pressure without use of downstream flange.
- d. Body Material: ASTM A 126, cast iron or ASTM A 536, ductile iron.
- e. Seat: EPDM.
- f. Stem: One- or two-piece stainless steel.
- g. Disc: Aluminum bronze.

2.4 GROOVED-END BUTTERFLY VALVES

A. 300 CWP, Iron, Grooved-End Butterfly Valves:

- 1. Manufacturers: Subject to compliance with requirements, provide products by one of the following:
 - a. Anvil International, Inc.
 - b. Kennedy Valve; a division of McWane, Inc.
 - c. Mueller Steam Specialty; a division of SPX Corporation.
 - d. NIBCO INC.
 - e. Victaulic Company.
- 2. Description:
 - a. Standard: MSS SP-67, Type I.
 - b. **NPS 8** and Smaller CWP Rating: **300 psig**.
 - c. **NPS 10** and Larger CWP Rating: **200 psig**.
 - d. Body Material: Coated, ductile iron.
 - e. Stem: Two-piece stainless steel.
 - f. Disc: Coated, ductile iron.
 - g. Seal: EPDM.

2.5 BRONZE SWING CHECK VALVES

A. Class 150, Bronze Swing Check Valves with Bronze Disc:

- 1. Manufacturers: Subject to compliance with requirements, provide products by one of the following:
 - a. Crane.
 - b. Milwaukee Valve Company.
 - c. NIBCO INC.
- 2. Description:
 - a. Standard: MSS SP-80, Type 3.
 - b. CWP Rating: **300 psig**.
 - c. Body Design: Horizontal flow.

- d. Body Material: ASTM B 62, bronze.
- e. Ends: Threaded.
- f. Disc: Bronze.

2.6 IRON SWING CHECK VALVES

A. Class 125, Iron Swing Check Valves with Metal Seats:

1. Manufacturers: Subject to compliance with requirements, provide products by one of the following:
 - a. Crane.
 - b. Hammond Valve.
 - c. Milwaukee Valve Company.
 - d. NIBCO INC.
 - e. Powell Valves.
 - f. Watts Regulator Co.; a division of Watts Water Technologies, Inc.
2. Description:
 - a. Standard: MSS SP-71, Type I.
 - b. CWP Rating: **200 psig**.
 - c. Body Design: Clear or full waterway.
 - d. Body Material: ASTM A 126, gray iron with bolted bonnet.
 - e. Ends: Flanged.
 - f. Trim: Bronze.
 - g. Gasket: Asbestos free.

2.7 IRON, GROOVED-END SWING CHECK VALVES

A. 300 CWP, Iron, Grooved-End Swing Check Valves:

1. Manufacturers: Subject to compliance with requirements, provide products by one of the following:
 - a. Anvil International, Inc.
 - b. Victaulic Company.
2. Description:
 - a. CWP Rating: **300 psig**.
 - b. Body Material: ASTM A 536, ductile iron.
 - c. Seal: EPDM.
 - d. Disc: Spring-operated, ductile iron or stainless steel.

2.8 BRONZE GATE VALVES

A. Class 150, RS Bronze Gate Valves:

1. Manufacturers: Subject to compliance with requirements, provide products by one of the following:
 - a. Crane.
 - b. Hammond Valve.
 - c. Milwaukee Valve Company.
 - d. NIBCO INC.
 - e. Powell Valves.
 - f. Watts Regulator Co.; a division of Watts Water Technologies, Inc.

2. Description:
 - a. Standard: MSS SP-80, Type 2.
 - b. CWP Rating: 300 psig.
 - c. Body Material: ASTM B 62, bronze with integral seat and union-ring bonnet.
 - d. Ends: Threaded.
 - e. Stem: Bronze.
 - f. Disc: Solid wedge; bronze.
 - g. Packing: Asbestos free.
 - h. Handwheel: Malleable iron, bronze, or aluminum.

2.9 IRON GATE VALVES

A. Class 125, OS&Y, Iron Gate Valves:

1. Manufacturers: Subject to compliance with requirements, provide products by one of the following:
 - a. Crane.
 - b. Hammond Valve.
 - c. Milwaukee Valve Company.
 - d. NIBCO INC.
 - e. Powell Valves.
 - f. Watts Regulator Co.; a division of Watts Water Technologies, Inc.

2. Description:
 - a. Standard: MSS SP-70, Type I.
 - b. CWP Rating: 200 psig.
 - c. Body Material: ASTM A 126, gray iron with bolted bonnet.
 - d. Ends: Flanged.
 - e. Trim: Bronze.
 - f. Disc: Solid wedge.
 - g. Packing and Gasket: Asbestos free.

2.10 BRONZE GLOBE VALVES

A. Class 150, Bronze Globe Valves with Nonmetallic Disc:

1. Manufacturers: Subject to compliance with requirements, provide products by one of the following:
 - a. Crane.
 - b. Hammond Valve.
 - c. Milwaukee Valve Company.
 - d. NIBCO INC.
 - e. Powell Valves.
 - f. Watts Regulator Co.; a division of Watts Water Technologies, Inc.

2. Description:
 - a. Standard: MSS SP-80, Type 2.
 - b. CWP Rating: 300 psig.
 - c. Body Material: ASTM B 62, bronze with integral seat and union-ring bonnet.
 - d. Ends: Threaded.
 - e. Stem: Bronze.
 - f. Disc: PTFE or TFE.
 - g. Packing: Asbestos free.
 - h. Handwheel: Malleable iron, bronze, or aluminum.

2.11 IRON GLOBE VALVES

A. Class 125, Iron Globe Valves:

1. Manufacturers: Subject to compliance with requirements, provide products by one of the following:
 - a. Crane.
 - b. Hammond Valve.
 - c. Milwaukee Valve Company.
 - d. NIBCO INC.
 - e. Powell Valves.
 - f. Watts Regulator Co.; a division of Watts Water Technologies, Inc.

2. Description:
 - a. Standard: MSS SP-85, Type I.
 - b. CWP Rating: 200 psig.
 - c. Body Material: ASTM A 126, gray iron with bolted bonnet.
 - d. Ends: Flanged.
 - e. Trim: Bronze.
 - f. Packing and Gasket: Asbestos free.

PART 3 - EXECUTION

3.1 EXAMINATION

- A. Examine valve interior for cleanliness, freedom from foreign matter, and corrosion. Remove special packing materials, such as blocks, used to prevent disc movement during shipping and handling.
- B. Operate valves in positions from fully open to fully closed. Examine guides and seats made accessible by such operations.
- C. Examine threads on valve and mating pipe for form and cleanliness.
- D. Examine mating flange faces for conditions that might cause leakage. Check bolting for proper size, length, and material. Verify that gasket is of proper size, that its material composition is suitable for service, and that it is free from defects and damage.
- E. Do not attempt to repair defective valves; replace with new valves.

3.2 VALVE INSTALLATION

- A. Install valves with unions or flanges at each piece of equipment arranged to allow service, maintenance and equipment removal without system shutdown.
- B. Locate valves for easy access and provide separate support where necessary.
- C. Install valves in horizontal piping with stem at or above center of pipe.
- D. Install valves in position to allow full stem movement.
- E. Install chainwheels on operators for valves NPS 8 and larger and more than 15' above floor. Extend chains to **60 inches** above finished floor.
- F. Install check valves for proper direction of flow and as follows:
 - 1. Swing Check Valves: In horizontal position with hinge pin level.
 - 2. Lift Check Valves: With stem upright and plumb.

3.3 ADJUSTING

- A. Adjust or replace valve packing after piping systems have been tested and put into service but before final adjusting and balancing. Replace valves if persistent leaking occurs.

3.4 GENERAL REQUIREMENTS FOR VALVE APPLICATIONS

- A. If valve applications are not indicated, use the following:
1. Shutoff Service: Ball, butterfly, or gate valves.
 2. Butterfly Valve Dead-End Service: Single-flange (lug) type.
 3. Throttling Service: Globe or butterfly valves.
- B. If valves with specified SWP classes or CWP ratings are not available, the same types of valves with higher SWP classes or CWP ratings may be substituted.
- C. Select valves, except wafer types, with the following end connections:
1. For Copper Tubing, **NPS 2** and Smaller: Threaded ends .
 2. For Copper Tubing, **NPS 2-1/2 to NPS 4**: Flanged ends.
 3. For Copper Tubing, **NPS 5** and Larger: Flanged ends.
 4. For Steel Piping, **NPS 2** and Smaller: Threaded ends.
 5. For Steel Piping, **NPS 2-1/2 to NPS 4**: Flanged ends.
 6. For Steel Piping, **NPS 5** and Larger: Flanged ends.
 7. For Grooved-End Copper Tubing and Steel Piping: Valve ends may be grooved.

3.5 DOMESTIC, HOT- AND COLD-WATER VALVE SCHEDULE

- A. Pipe **NPS 2** and Smaller:
1. Bronze Valves: Threaded ends.
 2. Ball Valves.
 3. Bronze Swing Check Valves.
 4. Bronze Gate Valves.
 5. Bronze Globe Valves.
- B. Pipe **NPS 2-1/2** and Larger:
1. Iron Valves, **NPS 2-1/2 to NPS 4**: Flanged ends.
 2. Iron, Lug type Valves.
 3. Iron, Grooved-End Butterfly Valves.
 4. Iron Swing Check Valves.
 5. Iron, Grooved-End Swing Check Valves.
 6. Iron Gate Valves.
 7. Iron Globe Valves.

3.6 HYDRONIC HEATING WATER

- A. Pipe **NPS 2** and Smaller:

1. Bronze Valves: Threaded ends.
2. Ball Valves.
3. Bronze Swing Check Valves.
4. Bronze Gate Valves.
5. Bronze Globe Valves

B. Pipe **NPS 2-1/2** and Larger:

1. Iron Valves, **NPS 2-1/2 to NPS 4**: Flanged ends.
2. Iron, Lug type Valves.
3. Iron, Grooved-End Butterfly Valves.
4. Iron Swing Check Valves.
5. Iron, Grooved-End Swing Check Valves.
6. Iron Gate Valves.
7. Iron Globe Valves.

END OF SECTION 200523

SECTION 200529 – MECHANICAL HANGERS AND SUPPORTS

PART 1 - GENERAL

1.1 RELATED DOCUMENTS

- A. Drawings and general provisions of the Contract, including General and Supplementary Conditions and Division 1 Specification Sections, apply to this Section.

1.2 SUMMARY

- A. This Section includes the following hangers and supports for piping and equipment:
 - 1. Steel pipe hangers and supports.
 - 2. Trapeze pipe hangers.
 - 3. Metal framing systems.
 - 4. Thermal-hanger shield inserts.
 - 5. Fastener systems.
- B. This Section applies to Hangers and Supports for items specified in Division(s) 20, 21, 22 and 23.
- C. Related Sections include the following:
 - 1. Division 21 Section "Fire-Suppression Piping" for additional pipe hanger requirements for fire-suppression piping.

1.3 DEFINITIONS

- A. MSS: Manufacturers Standardization Society for The Valve and Fittings Industry Inc.
- B. Terminology: As defined in MSS SP-90, "Guidelines on Terminology for Pipe Hangers and Supports."

1.4 PERFORMANCE REQUIREMENTS

- A. Design supports for multiple pipes, including pipe stands, capable of supporting combined weight of supported systems, system contents, and test water.

1.5 SUBMITTALS

- A. Product Data: For the following:

1. Steel pipe hangers and supports.
2. Thermal-hanger shield inserts.

B. Welding certificates.

1.6 QUALITY ASSURANCE

- A. Welding: Qualify procedures and personnel according to AWS D1.1, "Structural Welding Code--Steel.", AWS D1.4, "Structural Welding Code--Reinforcing Steel.", and ASME Boiler and Pressure Vessel Code: Section IX.

PART 2 - PRODUCTS

2.1 MANUFACTURERS

- A. In other Part 2 articles where titles below introduce lists, the following requirements apply to product selection:

1. Manufacturers: Subject to compliance with requirements, provide products by one of the manufacturers specified.

2.2 STEEL PIPE HANGERS AND SUPPORTS

- A. Description: Factory-fabricated components. Refer to Part 3 "Hanger and Support Applications" Article for where to use specific hanger and support types.

B. Manufacturers:

1. B-Line Systems, Inc.; a division of Cooper Industries.
2. Anvil International (formerly Grinnell Corp.)
3. Tolco Inc.

C. Galvanized, Metallic Coatings: Pregalvanized or hot dipped.

D. Nonmetallic Coatings: Plastic coating, jacket, or liner.

2.3 METAL FRAMING SYSTEMS

- A. Description: MFMA-3, shop- or field-fabricated pipe-support assembly made of steel channels and other components.

B. Manufacturers:

1. B-Line Systems, Inc.; a division of Cooper Industries.

2. Power-Strut Div.; Tyco International, Ltd.
3. Tolco Inc.
4. Unistrut Corp.; Tyco International, Ltd.

C. Coatings: Manufacturer's standard finish unless bare metal surfaces are indicated.

D. Nonmetallic Coatings: Plastic coating, jacket, or liner.

2.4 THERMAL-HANGER SHIELD INSERTS

A. Description: 100-psig- minimum, compressive-strength insulation insert encased in sheet metal shield. Pre manufactured combination insert/shield assembly or separate components field assembled.

B. Manufacturers:

1. Buckaroos.
2. ERICO/Michigan Hanger Co.
3. PHS Industries, Inc.
4. Pipe Shields, Inc.
5. Rilco Manufacturing Company, Inc.
6. Value Engineered Products, Inc.

C. Insulation-Insert Material for Cold Piping: Water-repellent treated, ASTM C 533, Type I calcium silicate or ASTM C 552, Type II cellular glass with vapor barrier. Calcium silicate is not allowed on copper piping. Provide cellular glass on copper piping.

D. Insulation-Insert Material for Hot Piping: Water-repellent treated, ASTM C 533, Type I calcium silicate or ASTM C 552, Type II cellular glass. Calcium silicate is not allowed on copper piping. Provide cellular glass on copper piping.

E. For Trapeze or Clamped Systems: Insert and shield shall cover entire circumference of pipe.

F. For Clevis or Band Hangers: Insert and shield shall cover lower 180 degrees of pipe.

G. Shield shall be minimum 16 gauge galvanized sheet metal.

H. Insert Length

Pipe Size	Insert Length
1-1/2" to 2-1/2"	10"
3" to 6"	12"
8" to 10"	16"
12" and larger	22"

I. Minimum shield length

Pipe Size	Shield Length
1-1/2" to 2-1/2"	6"
3" to 6"	8"
8" to 10"	12"
12" and larger	18"

2.5 FASTENER SYSTEMS

A. Mechanical-Expansion Anchors: Insert-wedge-type stainless steel, for use in hardened portland cement concrete with pull-out, tension, and shear capacities appropriate for supported loads and building materials where used.

1. Manufacturers:

- a. B-Line Systems, Inc.; a division of Cooper Industries.
- b. Hilti, Inc.
- c. ITW Ramset/Red Head.

2.6 MISCELLANEOUS MATERIALS

A. Structural Steel: ASTM A 36/A 36M, steel plates, shapes, and bars; black and galvanized.

PART 3 - EXECUTION

3.1 HANGER AND SUPPORT APPLICATIONS

- A. Specific hanger and support requirements are specified in Sections specifying piping systems and equipment.
- B. Comply with MSS SP-69 for pipe hanger selections and applications that are not specified in piping system Sections.
- C. Contractor shall be responsible to provide building attachments, hangers, etc. properly sized for the load supported.
- D. Use hangers and supports with galvanized, metallic coatings.
 - 1. Supports that are specified to be field painted shall have plain finish.
- E. Use nonmetallic coatings on attachments for electrolytic protection where attachments are in direct contact with copper tubing.
- F. Horizontal-Piping Hangers and Supports: Unless otherwise indicated and except as specified in piping system Sections, install the following types:
 - 1. Adjustable, Steel Clevis Hangers (MSS Type 1): For suspension of noninsulated or insulated stationary pipes, **NPS 1/2 to NPS 30**.
 - 2. Carbon- or Alloy-Steel, Double-Bolt Pipe Clamps (MSS Type 3): For suspension of pipes, **NPS 3/4 to NPS 24**, requiring clamp flexibility and up to **4 inches** of insulation.
 - 3. Steel Pipe Clamps (MSS Type 4): For suspension of cold and hot pipes, **NPS 1/2 to NPS 24**, if little or no insulation is required.
 - 4. Pipe Hangers (MSS Type 5): For suspension of pipes, **NPS 1/2 to NPS 2**, to allow off-center closure for hanger installation before pipe erection.
 - 5. Adjustable, Steel Band Hangers (MSS Type 7): For suspension of noninsulated stationary pipes, **NPS 1/2 to NPS 2**.
- G. Vertical-Piping Clamps: Unless otherwise indicated and except as specified in piping system Sections, install the following types:
 - 1. Extension Pipe or Riser Clamps (MSS Type 8): For support of pipe risers, **NPS 3/4 to NPS 20**.
 - 2. Carbon- or Alloy-Steel Riser Clamps (MSS Type 42): For support of pipe risers, **NPS 3/4 to NPS 20**, if longer ends are required for riser clamps.
- H. Hanger-Rod Attachments: Unless otherwise indicated and except as specified in piping system Sections, install the following types:
 - 1. Steel Clevises (MSS Type 14): For **120 to 450 deg F** piping installations.
 - 2. Swivel Turnbuckles (MSS Type 15): For use with MSS Type 11, split pipe rings.

3. Steel Weldless Eye Nuts (MSS Type 17): For 120 to 450 deg F piping installations.
- I. Building Attachments: Unless otherwise indicated and except as specified in piping system Sections, install the following types:
 1. Side-Beam or Channel Clamps (MSS Type 20): For attaching to bottom flange of beams, channels, or angles.
 2. Center-Beam Clamps (MSS Type 21): For attaching to center of bottom flange of beams.
 3. C-Clamps (MSS Type 23): For structural shapes.
 4. Top-Beam Clamps (MSS Type 25): For top of beams if hanger rod is required tangent to flange edge.
 5. Side-Beam Clamps (MSS Type 27): For bottom of steel I-beams.
 6. Malleable Beam Clamps with Extension Pieces (MSS Type 30): For attaching to structural steel.
 7. Side-Beam Brackets (MSS Type 34): For sides of concrete beams and joists.
 - J. Saddles and Shields: Unless otherwise indicated and except as specified in piping system Sections, install the following types:
 1. Steel Pipe-Covering Protection Saddles (MSS Type 39): To fill interior voids with insulation that matches adjoining insulation.
 2. Protection Shields (MSS Type 40): Of length recommended in writing by manufacturer to prevent crushing insulation.
 3. Thermal-Hanger Shield Inserts: For supporting insulated pipe.
 - K. Comply with MFMA-102 for metal framing system selections and applications that are not specified in piping system Sections.
 - L. Mechanical expansion anchors shall not be installed in the underside of concrete beams or joists, nor shall they be installed between structural beams or joists. Mechanical-expansion anchors shall not be installed in composite metal deck construction.
 - M. The use of powder actuated fasteners is prohibited.
 - N. Use pipe positioning systems in pipe spaces behind plumbing fixtures to support supply and waste piping for plumbing fixtures.
- 3.2 HANGER AND SUPPORT INSTALLATION
- A. Steel Pipe Hanger Installation: Comply with MSS SP-69 and MSS SP-89. Install hangers, supports, clamps, and attachments as required to properly support piping from building structure.
 - B. Trapeze Pipe Hanger Installation: Comply with MSS SP-69 and MSS SP-89. Arrange for grouping of parallel runs of horizontal piping and support together on field-fabricated trapeze pipe hangers.

1. Pipes of Various Sizes: Support together and space trapezes for smallest pipe size or install intermediate supports for smaller diameter pipes as specified above for individual pipe hangers.
 2. Field fabricate from ASTM A 36/A 36M, steel shapes selected for loads being supported. Weld steel according to AWS D1.1.
- C. Metal Framing System Installation: Arrange for grouping of parallel runs of piping and support together on field-assembled metal framing systems.
- D. Thermal-Hanger Shield Installation: Provide for support of insulated piping 1-1/4" nominal diameter and larger.
- E. Fastener System Installation:
1. Install mechanical-expansion anchors in concrete after concrete is placed and completely cured. Install fasteners according to manufacturer's written instructions.
- F. Install hangers and supports complete with necessary inserts, bolts, rods, nuts, washers, and other accessories.
- G. Install hangers and supports to allow controlled thermal movement of piping systems, to permit freedom of movement between pipe anchors, and to facilitate action of expansion joints, expansion loops, expansion bends, and similar units.
- H. Install lateral bracing with pipe hangers and supports to prevent swaying.
- I. Hanger Rod Diameters:

Pipe Size	Diameter
1/2" to 2"	3/8"
2-1/2" to 3"	1/2"
4" to 5"	5/8"
6"	3/4"
8" to 12"	7/8"
14" and larger	1"
PVC to 3"	3/8"

PVC over 3"	1/2"
-------------	------

J. Pipe Hanger Maximum Spacing

Pipe Size	Cast Iron Pipe	Steel & Copper Pipe	Plastic Pipe
1/2" to 1-1/4"	4'	5'	4'
1-1/2" to 2-1/4"	4'	6'	4'
2-1/2" to 3"	4'	10'	4'
4" to 6"	4'	10'	4'
8" to 12"	4'	10'	4'
14" and Larger	4'	10'	4'
All Sizes	At each fitting, coupling & change of direction.	At each fitting & change of direction.	At each fitting & change of direction.

K. In addition to the spacing specified, install supports at concentrated loads, including valves, flanges, and strainers, and at changes in direction of piping.

L. Load Distribution: Install hangers and supports so piping live and dead loads and stresses from movement will not be transmitted to connected equipment.

M. Pipe Slopes: Install hangers and supports to provide indicated pipe slopes and so maximum pipe deflections allowed by ASME B31.9 (for building services piping) are not exceeded.

N. Insulated Piping: Comply with the following:

1. Attach clamps and spacers to piping.
 - a. Insulated piping: Use thermal-hanger shield insert with clamp sized to match OD of insert.
 - b. Do not exceed pipe stress limits according to ASME B31.9 for building services piping.
 - c. Install MSS SP-58, Type 39, protection saddles in conjunction with pipe roll hangers.

2. Install MSS SP-58, Type 40, protective shields on insulated piping. Shields shall span an arc of 180 degrees. Thermal-hanger shield inserts shall be used on insulated piping 1-1/4" nominal diameter and larger.
3. Shield Dimensions for Pipe: Refer to table in Part 2
4. Pipes **NPS 8** and Larger: Include flame retardant wood inserts.
5. Insert Material: Calcium silicate or cellular glass. Do not use calcium silicate on copper piping. Length as indicated below.
6. Thermal-Hanger Shields: Install with insulation same thickness as piping insulation.

3.3 METAL FABRICATIONS

- A. Cut, drill, and fit miscellaneous metal fabrications for trapeze pipe hangers.
- B. Fit exposed connections together to form hairline joints. Field weld connections that cannot be shop welded because of shipping size limitations.
- C. Field Welding: Comply with AWS D1.1 procedures for shielded metal arc welding, appearance and quality of welds, and methods used in correcting welding work, and with the following:
 1. Use materials and methods that minimize distortion and develop strength and corrosion resistance of base metals.
 2. Obtain fusion without undercut or overlap.
 3. Remove welding flux immediately.
 4. Finish welds at exposed connections so no roughness shows after finishing and contours of welded surfaces match adjacent contours.

3.4 ADJUSTING

- A. Hanger Adjustments: Adjust hangers to distribute loads equally on attachments and to achieve indicated slope of pipe.
- B. Trim excess length of continuous-thread hanger and support rods to 1 inch.

3.5 PAINTING

- A. Prime coat all steel hangers and supports.
- B. Touch Up: Clean field welds and abraded areas of shop paint. Paint exposed areas immediately after erecting hangers and supports. Use same materials as used for shop painting. Comply with SSPC-PA 1 requirements for touching up field-painted surfaces.
 1. Apply paint by brush or spray to provide minimum dry film thickness of **2.0 mils**.
- C. Touch Up: Cleaning and touchup painting of field welds, bolted connections, and abraded areas of shop paint on miscellaneous metal are specified elsewhere.

- D. Galvanized Surfaces: Clean welds, bolted connections, and abraded areas and apply galvanizing-repair paint to comply with ASTM A 780.

END OF SECTION 200529

SECTION 200553 – MECHANICAL IDENTIFICATION AND PAINTING

PART 1 - GENERAL

1.1 RELATED DOCUMENTS

- A. Drawings and general provisions of the Contract, including General and Supplementary Conditions and Division 1 Specification Sections, apply to this Section.

1.2 SUMMARY

- A. Section Includes:
 - 1. Equipment labels.
 - 2. Pipe labels.
 - 3. Duct labels.
 - 4. Ceiling Tags
 - 5. Valve tags.
 - 6. Painting Requirements

1.3 SUBMITTALS

- A. Product Data: For each type of product indicated.
- B. Equipment Label Schedule: Include a listing of all equipment to be labeled with the proposed content for each label.
- C. Valve numbering scheme.
- D. Valve Schedules: For each piping system to include in maintenance manuals.
- E. Paint color coding identification chart.

1.4 COORDINATION

- A. Coordinate installation of identifying devices with completion of covering and painting of surfaces where devices are to be applied.
- B. Coordinate installation of identifying devices with locations of access panels and doors.
- C. Install identifying devices before installing acoustical ceilings and similar concealment.

PART 2 - PRODUCTS

2.1 EQUIPMENT LABELS

A. Plastic Labels for Equipment:

1. Material and Thickness: Multilayer, multicolor, plastic labels for mechanical engraving, **1/8 inch** thick, and having predrilled holes for attachment hardware.
2. Letter Color: White.
3. Background Color: Black.
4. Maximum Temperature: Able to withstand temperatures up to **160 deg F**.
5. Minimum Label Size: Length and width vary for required label content, but not less than **2-1/2 by 3/4 inch**.
6. Minimum Letter Size: **1/4 inch** for name of units if viewing distance is less than **24 inches**, **1/2 inch** for viewing distances up to **72 inches**, and proportionately larger lettering for greater viewing distances. Include secondary lettering two-thirds to three-fourths the size of principal lettering.
7. Adhesive: Contact-type permanent adhesive, compatible with label and with substrate.

B. Label Content: Include equipment's Drawing designation and unique equipment number.

C. Equipment Label Schedule: For each item of equipment to be labeled, on **8-1/2-by-11-inch** bond paper. Tabulate equipment identification number and identify type of equipment and location. Equipment schedule shall be included in operation and maintenance data.

2.2 PIPE LABELS

A. General Requirements for Manufactured Pipe Labels: Preprinted, color-coded, with lettering indicating service, and showing flow direction.

B. Pretensioned Pipe Labels: Precoiled, semirigid plastic formed to cover full circumference of pipe and to attach to pipe without fasteners or adhesive.

C. Self-Adhesive Pipe Labels: Printed plastic with contact-type, permanent-adhesive backing.

D. Pipe Label Contents: Include identification of piping service using same designations or abbreviations as used on Drawings, and an arrow indicating flow direction.

1. Flow-Direction Arrows: Integral with piping system service lettering to accommodate both directions, or as separate unit on each pipe label to indicate flow direction. Arrow shall be 6" long minimum.
2. Lettering Size: Comply with the following

Pipe or Covering O.D.	Field Length (Min.)	Letter Size (Min.)
1-1/4" and under	8"	1/2"
1-1/2" through 2"	8"	3/4"
2-1/2" through 6"	12"	1-1/4"
8" through 10"	24"	2-1/2"
10" and over	32"	3-1/2"

2.3 DUCT LABELS

- A. Material and Thickness: Multilayer, multicolor, plastic labels for mechanical engraving, 1/8 inch thick, and having predrilled holes for attachment hardware.
- B. Letter Color: White.
- C. Background Color: Black.
- D. Maximum Temperature: Able to withstand temperatures up to 160 deg F.
- E. Minimum Label Size: Length and width vary for required label content, but not less than 2-1/2 by 3/4 inch.
- F. Minimum Letter Size: 1/4 inch for name of units if viewing distance is less than 24 inches, 1/2 inch for viewing distances up to 72 inches, and proportionately larger lettering for greater viewing distances. Include secondary lettering two-thirds to three-fourths the size of principal lettering.
- G. Adhesive: Contact-type permanent adhesive, compatible with label and with substrate.
- H. Duct Label Contents: Include identification of duct service using same designations or abbreviations as used on Drawings, duct size, and an arrow indicating flow direction.
 - 1. Flow-Direction Arrows: Integral with duct system service lettering to accommodate both directions, or as separate unit on each duct label to indicate flow direction. 6" long minimum.
 - 2. Lettering Size: At least 1-1/2 inches high.

2.4 CEILING TAGS

- A. ½ inch diameter colored, pressure sensitive adhesive paper circles. Provide colors to match the schedule below:
1. Heating Water - Orange
 2. Chilled Water - Green
 3. Domestic Cold Water - Blue
 4. Domestic Hot Water - Red
 5. Steam Supply - Yellow
 6. Steam Return - Purple

2.5 VALVE TAGS

- A. Valve Tags: Stamped or engraved with 1/4-inch letters for piping system abbreviation and 1/2-inch numbers.
1. Tag Material: Brass, 0.032-inch minimum thickness, and having predrilled or stamped holes for attachment hardware.
 2. Fasteners: Brass wire-link or beaded chain; or S-hook.
- B. Valve Schedules: For each piping system, on 8-1/2-by-11-inch bond paper. Tabulate valve number, piping system, system abbreviation (as shown on valve tag), location of valve (room or space), normal-operating position (open, closed, or modulating), and variations for identification. Mark valves for emergency shutoff and similar special uses.
1. Valve-tag schedule shall be included in operation and maintenance data.
 2. Valve-tag schedule shall be framed under glass and mounted on the wall in a location as directed by the owner.
 3. Valve tagging identification numbers shall have a unique prefix to indicate system, and a sequential number to further identify each valve.

2.6 CORROSION RESISTANT PAINT

- A. Rust resistant paint equal to Rustoleum

PART 3 - EXECUTION

3.1 PREPARATION

- A. Clean piping and equipment surfaces of substances that could impair bond of identification devices, including dirt, oil, grease, release agents, and incompatible primers, paints, and encapsulants.

3.2 EQUIPMENT LABEL INSTALLATION

- A. Install or permanently fasten labels on each major item of mechanical equipment.
- B. Locate equipment labels where accessible and visible.

3.3 PAINTING

- A. Refer to Division 9 requirements for painting and painting materials. Mechanical piping, ductwork, hangers, equipment, etc. exposed in finished areas shall be painted except for the following.
 - 1. Items that have a UL listing which prohibits field painting.
 - 2. Grilles/Registers and Diffusers with a factory applied finish, with finish approved by the architect.
- B. Refer to Division 9 requirements for painting and painting materials. Mechanical piping, ductwork, hangers, equipment, etc. shall be painted except for the following:
 - 1. Concealed piping and ductwork.
 - 2. Ductwork in mechanical rooms and accessible shafts.
 - 3. Sanitary waste and vent piping, unless exposed in a finished space.
 - 4. Equipment with factory applied finish.
 - 5. Items that have a UL listing which prohibits field painting.]
- C. Color Code: In mechanical rooms, utility tunnels, and accessible mechanical shafts, all piping shall be identified by color code and all piping shall be completely painted the color as specified. Heat exchangers, tanks, etc. shall be painted the same color as the piping system connected to it.

Item	Label	Color	Glidden	Rustoleum
Fire Lines, Sprinklers, etc.	FL	Red	4520	964
Condenser Water Supply	CWS	Dark Blue	4564	721
Condenser Water Return	CWR	Dark Blue	4564	721
Chilled Water Supply	CHWS	Dark Green	4554	H-3
Chilled Water Return	CHWR	Dark Green	4554	H-3
Hot Water Heating Supply	HWHS	Light Green	71-L-2	H-27

Hot Water Heating Return	HWHR	Light Green	71-L-2	H-27
Dual Temp. Water Supply	DTWS	Light Green	71-L-2	H-27
Dual Temp. Water Return	DTWR	Light Green	71-L-2	H-27
Heat Reclaim Piping	HR	Light Green	71-L-2	H-27
Low Pressure Steam Supply	LPSS	Gray	4572	975
Low Pressure Condensate	LPSR	Dark Blue	4564	721
High Pressure Steam Supply	HPSS	Gray	4572	975
High Pressure Condensate	HPSR	Dark Blue	4564	721
Sanitary Waste	W	Black	4551	978
Sanitary Vent	V	Black	4551	978
Acid Proof Waste	APW	Black	4551	978
Acid Proof Vent	APV	Black	4551	978
Storm Sewer and Downspout	DS	Black	4551	978
Air Conditioner Drain	ACD	Black	4551	978
Potable Cold Water	PCW	Light Blue	80-L-2	866
Potable Hot Water	PHW	Light Blue	80-L-2	866
General Cold Water	PCW - General	Light Blue	80-L-2	866
General Hot Water	PHW - General	Light Blue	80-L-2	866
Hot Water Recirculating	HWR	Light Blue	80-L-2	866
Non-Potable Water	NPW	Orange	4510	956

Laboratory Water	LPW	Light Blue	80-L-2	866
Direct Expansion	R-12, 22, etc	Dark Brown	4537	977
Refrigerant Ammonia	REF - AMM	Dark Brown	4537	977
Refrigerant Brine	REF - BR	Dark Brown	4537	977
Water Softener Brine	WSB	Dark Brown	4537	977
Nitrogen	N2	Dark Brown	4537	977
Oil	OIL	Light Brown		865
Carbon Dioxide	CO2	Red	4520	964
Hydrogen Sulfide	H2S	Light Brown		865
Vacuum	VAC	Light Green	71L2	H-27
Natural Gas	GAS	Dark Green	4554	H-3
LP Gas	LP GAS	Dark Green	4554	H-3
Air	AIR	Yellow	4540	944
Oxygen - Medical	O2	Dark Green	4554	H-3
Oxygen - Welding	OXY	Dark Green	4554	H-3
Acetylene	ACY	Maroon		745
Nitrous Oxide	NOx	Light Brown		865

D. Paint the interior metal surfaces of ducts that are visible through grilles flat black.

3.4 PIPE LABEL INSTALLATION

- A. Locate pipe labels where piping is exposed or above accessible ceilings in finished spaces; mechanical equipment rooms; accessible maintenance spaces such as shafts, tunnels, and plenums; and exterior exposed locations as follows:
1. Near each valve and control device.
 2. Near each branch connection, excluding short takeoffs for fixtures and terminal units. Where flow pattern is not obvious, mark each pipe at branch.
 3. Near penetrations through walls, floors, ceilings, and inaccessible enclosures.
 4. At access doors, manholes, and similar access points that permit view of concealed piping.
 5. Near major equipment items and other points of origination and termination.
 6. Spaced at maximum intervals of **50 feet** along each run. Reduce intervals to **25 feet** in areas of congested piping and equipment.
 7. On piping above removable acoustical ceilings.

3.5 DUCT LABEL INSTALLATION

- A. Install plastic-laminated duct labels with permanent adhesive on air ducts as follows:
1. Exhaust ductwork located in mechanical equipment rooms and located on the roof. Identify exhaust system connected to and room served.
 2. ASME A13.1 Colors and Designs: For hazardous material exhaust.
- B. Locate labels near points where ducts enter into concealed spaces and at maximum intervals of 20 ft.

3.6 CEILING TAG INSTALLATION

- A. All locations of HVAC and domestic water system valves requiring valve tags shall be identified using ceiling tags. Appropriately colored tags should be applied to the ceiling grid directly below the applicable valve. Tags applied to ceiling pads will not be accepted.

3.7 VALVE-TAG INSTALLATION

- A. Install tags on valves and control devices in piping systems, except check valves; valves within factory-fabricated equipment units; fixture stops; faucets; and convenience and lawn-watering hose connections. List tagged valves in a valve schedule.

END OF SECTION 200553

SECTION 200700 – MECHANICAL INSULATION

PART 1 - GENERAL

1.1 RELATED DOCUMENTS

- A. Drawings and general provisions of the Contract, including General and Supplementary Conditions and Division 1 Specification Sections, apply to this Section.

1.2 SUMMARY

- A. This Section includes mechanical insulation for boiler breeching, duct, equipment, and pipe, including the following:

- 1. Insulation Materials:
 - a. Flexible elastomeric.
 - b. Fiberglass.
- 2. Insulating cements.
- 3. Adhesives.
- 4. Mastics.
- 5. Sealants.
- 6. Factory-applied jackets.
- 7. Field-applied jackets.
- 8. Tapes.

- B. This Section applies to work specified as part of Division 20, 21, 22 and 23.

- C. Related Sections include the following:

- 1. Division 23 Section "Metal Ducts" for duct liners.
- 2. Division 7 Section "Firestopping" for firestopping materials and requirements through fire and smoke barriers.

1.3 DEFINITIONS

- A. ASJ: All-service jacket.
- B. FSK: Foil, scrim, kraft paper.

1.4 SUBMITTALS

- A. Product Data: For each type of product indicated, identify thermal conductivity, thickness, and jackets (both factory and field applied, if any). Include data for adhesives, mastics, securements, etc.
- B. Schedule: Submit schedule indicating insulation type, thicknesses, and jacket to be used for each item to be insulated.

1.5 QUALITY ASSURANCE

- A. Fire-Test-Response Characteristics: Insulation and related materials shall have fire-test-response characteristics indicated, as determined by testing identical products per ASTM E 84, by a testing and inspecting agency acceptable to authorities having jurisdiction. Factory label insulation and jacket materials and adhesive, mastic, and cement material containers, with appropriate markings of applicable testing and inspecting agency.
 - 1. Flame-spread index of 25 or less, and smoke-developed index of 50 or less.

1.6 DELIVERY, STORAGE, AND HANDLING

- A. Packaging: Insulation material containers shall be marked by manufacturer with appropriate ASTM standard designation, type and grade, and maximum use temperature.
- B. Storage: Store insulation in a safe, dry, clean environment. Insulation containing moisture, and/or not stored properly will not be accepted.

1.7 COORDINATION

- A. Coordinate size and location of supports, hangers, and insulation shields specified in Division 20 Section "Hangers and Supports."
- B. Coordinate clearance requirements with piping Installer for piping insulation application, duct Installer for duct insulation application, and equipment Installer for equipment insulation application. Before preparing piping and ductwork Shop Drawings, establish and maintain clearance requirements for installation of insulation and field-applied jackets and finishes and for space required for maintenance.

1.8 SCHEDULING

- A. Schedule insulation application after pressure testing systems and, where required, after installing and testing heat tracing. Insulation application may begin on segments that have satisfactory test results.

PART 2 - PRODUCTS

2.1 MANUFACTURERS

- A. In other Part 2 articles where titles below introduce lists, the following requirements apply to product selection:
1. Manufacturers: Subject to compliance with requirements, provide products by one of the manufacturers specified.

2.2 INSULATION MATERIALS

- A. Refer to Part 3 schedule articles for requirements about where insulating materials shall be applied.
- B. Products shall not contain asbestos, lead, mercury, or mercury compounds.
- C. Products that come in contact with stainless steel shall have a leachable chloride content of less than 50 ppm when tested according to ASTM C 871.
- D. Insulation materials for use on austenitic stainless steel shall be qualified as acceptable according to ASTM C 795.
- E. Foam insulation materials shall not use CFC or HCFC blowing agents in the manufacturing process.
- F. Flexible Elastomeric: Closed-cell, sponge- or expanded-rubber materials. Comply with ASTM C 534, Type I for tubular materials and Type II for sheet materials.
1. Manufacturers:
 - a. Armacell LLC; AP Armaflex.
 - b. RBX Corporation; Insul-Sheet 1800 and Insul-Tube 180.
 2. K factor: .28 at 75 deg. F.
- G. Fiberglass Blanket Insulation: Mineral or glass fibers bonded with a thermosetting resin. Comply with ASTM C 553, Type II and ASTM C 1290, Type III with factory-applied FSK jacket. Factory-applied jacket requirements are specified in Part 2 "Factory-Applied Jackets" Article.
1. Manufacturers:

- a. CertainTeed Corp.; Duct Wrap.
 - b. Johns Manville; Microlite.
 - c. Knauf Insulation; Duct Wrap.
 - d. Manson Insulation Inc.; Alley Wrap.
 - e. Owens Corning; All-Service Duct Wrap.
2. K factor: .28 at 75 deg. F.
- H. Fiberglass Board Insulation: Mineral or glass fibers bonded with a thermosetting resin. Comply with ASTM C 612, Type IA or Type IB. For duct and plenum applications, provide insulation with factory-applied ASJ or with factory-applied FSK jacket. For equipment applications, provide insulation with factory-applied ASJ or with factory-applied FSK jacket. See insulation schedules for application. Factory-applied jacket requirements are specified in Part 2 "Factory-Applied Jackets" Article.
1. Manufacturers:
 - a. CertainTeed Corp.; Commercial Board.
 - b. Johns Manville; 800 Series Spin-Glas.
 - c. Knauf Insulation; Insulation Board.
 - d. Manson Insulation Inc.; AK Board.
 - e. Owens Corning; Fiberglas 700 Series.
 2. K factor: .23 at 75 deg. F.
- I. Fiberglass, Preformed Pipe Insulation:
1. Manufacturers:
 - a. Johns Manville; Micro-Lok.
 - b. Knauf Insulation; 1000(Pipe Insulation.
 - c. Manson Insulation Inc.; Alley-K.
 - d. Owens Corning; Fiberglas Pipe Insulation.
 2. Type I, 850 deg F Materials: Mineral or glass fibers bonded with a thermosetting resin. Comply with ASTM C 547, Type I, Grade A, with factory-applied ASJ. Factory-applied jacket requirements are specified in Part 2 "Factory-Applied Jackets" Article.
 3. K factor: .25@ 100 deg. F.
 4. Density: Minimum 3.5 lb/cubic ft.

2.3 INSULATING CEMENTS

- A. Mineral-Fiber Insulating Cement: Comply with ASTM C 195.

1. Manufacturers:

- a. Insulco, Division of MFS, Inc.; Triple I.
- b. P. K. Insulation Mfg. Co., Inc.; Super-Stik.

2.4 ADHESIVES

A. Materials shall be compatible with insulation materials, jackets, and substrates and for bonding insulation to itself and to surfaces to be insulated, unless otherwise indicated.

B. Flexible Elastomeric Adhesive: Comply with MIL-A-24179A, Type II, Class I.

1. Manufacturers:

- a. Aeroflex USA Inc.; Aeroseal.
- b. Armacell LCC; 520 Adhesive.
- c. Foster Products Corporation, H. B. Fuller Company; 85-75.
- d. RBX Corporation; Rubatex Contact Adhesive.

C. Fiberglass Adhesive: Comply with MIL-A-3316C, Class 2, Grade A.

1. Manufacturers:

- a. Childers Products, Division of ITW; CP-82.
- b. Foster Products Corporation, H. B. Fuller Company; 85-20.
- c. ITW TACC, Division of Illinois Tool Works; S-90/80.
- d. Marathon Industries, Inc.; 225.
- e. Mon-Eco Industries, Inc.; 22-25.

D. ASJ Adhesive, and FSK Jacket Adhesive: Comply with MIL-A-3316C, Class 2, Grade A for bonding insulation jacket lap seams and joints.

1. Manufacturers:

- a. Childers Products, Division of ITW; CP-82.
- b. Foster Products Corporation, H. B. Fuller Company; 85-20.
- c. ITW TACC, Division of Illinois Tool Works; S-90/80.
- d. Marathon Industries, Inc.; 225.
- e. Mon-Eco Industries, Inc.; 22-25.

E. PVC Jacket Adhesive: Compatible with PVC jacket.

1. Manufacturers:

- a. Dow Chemical Company (The); 739, Dow Silicone.
- b. Johns-Manville; Zeston Perma-Weld, CEEL-TITE Solvent Welding Adhesive.
- c. P.I.C. Plastics, Inc.; Welding Adhesive.

- d. Red Devil, Inc.; Celulon Ultra Clear.
- e. Speedline Corporation; Speedline Vinyl Adhesive.

2.5 MASTICS

- A. Materials shall be compatible with insulation materials, jackets, and substrates; comply with MIL-C-19565C, Type II.
- B. Vapor-Retarder Mastic: Water based; suitable for indoor and outdoor use on below ambient services.
 1. Manufacturers:
 - a. Childers Products, Division of ITW; CP-35.
 - b. Foster Products Corporation, H. B. Fuller Company; 30-90.
 - c. ITW TACC, Division of Illinois Tool Works; CB-50.
 - d. Marathon Industries, Inc.; 590.
 - e. Mon-Eco Industries, Inc.; 55-40.
 - f. Vimasco Corporation; 749.
 2. Water-Vapor Permeance: ASTM E 96, Procedure B, 0.013 perm at 43-mil dry film thickness.
 3. Service Temperature Range: Minus 20 to plus 180 deg F.
 4. Solids Content: ASTM D 1644, 59 percent by volume and 71 percent by weight.
 5. Color: White.

2.6 SEALANTS

- A. FSK and Metal Jacket Flashing Sealants:
 1. Manufacturers:
 - a. Childers Products, Division of ITW; CP-76-8.
 - b. Foster Products Corporation, H. B. Fuller Company; 95-44.
 - c. Marathon Industries, Inc.; 405.
 - d. Mon-Eco Industries, Inc.; 44-05.
 - e. Vimasco Corporation; 750.
 2. Materials shall be compatible with insulation materials, jackets, and substrates.
 3. Fire- and water-resistant, flexible, elastomeric sealant.
 4. Service Temperature Range: Minus 40 to plus 250 deg F.
 5. Color: Aluminum.
- B. ASJ Flashing Sealants, and PVC Jacket Flashing Sealants:
 1. Manufacturers:

- a. Childers Products, Division of ITW; CP-76.
2. Materials shall be compatible with insulation materials, jackets, and substrates.
3. Fire- and water-resistant, flexible, elastomeric sealant.
4. Service Temperature Range: Minus 40 to plus 250 deg F.
5. Color: White.

2.7 FACTORY-APPLIED JACKETS

- A. Provide factory applied jacket for all insulation types, except for flexible elastomeric. Comply with the following:
 1. ASJ: White, kraft-paper, fiberglass-reinforced scrim with aluminum-foil backing; complying with ASTM C 1136, Type I. Suitable for painting.
 2. FSK Jacket: Aluminum-foil, fiberglass-reinforced scrim with kraft-paper backing; complying with ASTM C 1136, Type II.

2.8 FIELD-APPLIED JACKETS

- A. Field-applied jackets shall comply with ASTM C 921, Type I, unless otherwise indicated.
- B. PVC Jacket: High-impact-resistant, UV-resistant PVC complying with ASTM D 1784, Class 16354-C; 30 mil thickness; roll stock ready for shop or field cutting and forming.
 1. Manufacturers:
 - a. Johns Manville; Zeston.
 - b. P.I.C. Plastics, Inc.; FG Series.
 - c. Proto PVC Corporation; LoSmoke.
 - d. Speedline Corporation; SmokeSafe.
 2. Adhesive: As recommended by jacket material manufacturer.
 3. Color: White.
 4. Factory-fabricated fitting covers to match jacket if available; otherwise, field fabricate.
 - a. Shapes: 45- and 90-degree, short- and long-radius elbows, tees, valves, flanges, unions, reducers, end caps, soil-pipe hubs, traps, mechanical joints, and P-trap and supply covers for lavatories.
 5. Factory-fabricated tank heads and tank side panels.

2.9 TAPES

- A. ASJ Tape: White vapor-retarder tape matching factory-applied jacket with acrylic adhesive, complying with ASTM C 1136 and UL listed.

1. Width: 3 inches.
 2. Thickness: 11.5 mils.
 3. Adhesion: 90 ounces force/inch in width.
 4. Elongation: 2 percent.
 5. Tensile Strength: 40 lbf/inch in width.
 6. ASJ Tape Disks and Squares: Precut disks or squares of ASJ tape.
- B. FSK Tape: Foil-face, vapor-retarder tape matching factory-applied jacket with acrylic adhesive; complying with ASTM C 1136 and UL listed.
1. Width: 3 inches.
 2. Thickness: 6.5 mils.
 3. Adhesion: 90 ounces force/inch in width.
 4. Elongation: 2 percent.
 5. Tensile Strength: 40 lbf/inch in width.
 6. FSK Tape Disks and Squares: Precut disks or squares of FSK tape.
- C. PVC Tape: White vapor-retarder tape matching field-applied PVC jacket with acrylic adhesive. Suitable for indoor and outdoor applications.
1. Width: 2 inches.
 2. Thickness: 6 mils.
 3. Adhesion: 64 ounces force/inch in width.
 4. Elongation: 500 percent.
 5. Tensile Strength: 18 lbf/inch in width.

PART 3 - EXECUTION

3.1 EXAMINATION

- A. Examine substrates and conditions for compliance with requirements for installation and other conditions affecting performance of insulation application.
1. Verify that systems and equipment to be insulated have been tested and are free of defects.
 2. Verify that surfaces to be insulated are clean and dry.
 3. Proceed with installation only after unsatisfactory conditions have been corrected.

3.2 PREPARATION

- A. Surface Preparation: Clean and dry surfaces to receive insulation. Remove materials that will adversely affect insulation application. Before insulating chilled water piping, apply a corrosion coating to insulated surfaces as follows:

1. Steel Pipe: Coat with an epoxy coating. Consult coating manufacturer for appropriate coating materials and application methods for operating temperature range.
- B. Mix insulating cements with clean potable water; if insulating cements are to be in contact with stainless-steel surfaces, use demineralized water.

3.3 COMMON INSTALLATION REQUIREMENTS

- A. Install insulation materials, accessories, and finishes with smooth, straight, and even surfaces; free of voids throughout the length of equipment, ducts and fittings, and piping including fittings, valves, and specialties.
- B. Install insulation materials, forms, vapor barriers or retarders, jackets, and thicknesses required for each item of equipment, duct system, and pipe system as specified in insulation system schedules.
- C. Install accessories compatible with insulation materials and suitable for the service. Install accessories that do not corrode, soften, or otherwise attack insulation or jacket in either wet or dry state.
- D. Install insulation with longitudinal seams at top and bottom of horizontal runs.
- E. Install multiple layers of insulation with longitudinal and end seams staggered.
- F. Do not weld brackets, clips, or other attachment devices to piping, fittings, and specialties.
- G. Keep insulation materials dry during application and finishing.
- H. Install insulation with tight longitudinal seams and end joints. Bond seams and joints with adhesive recommended by insulation material manufacturer.
- I. Install insulation with least number of joints practical.
- J. Where vapor barrier is indicated, seal joints, seams, and penetrations in insulation at hangers, supports, anchors, and other projections with vapor-barrier mastic.
 1. Install insulation continuously through hangers and around anchor attachments.
 2. For insulation application where vapor barriers are indicated, extend insulation on anchor legs from point of attachment to supported item to point of attachment to structure. Taper and seal ends at attachment to structure with vapor-barrier mastic.
 3. Install insert materials and install insulation to tightly join the insert. Seal insulation to insulation inserts with adhesive or sealing compound recommended by insulation material manufacturer.
 4. Cover inserts with jacket material matching adjacent pipe insulation. Install shields over jacket, arranged to protect jacket from tear or puncture by hanger, support, and shield.

- K. Apply adhesives, mastics, and sealants at manufacturer's recommended coverage rate and wet and dry film thicknesses.
- L. Install insulation with factory-applied jackets as follows:
 - 1. Draw jacket tight and smooth.
 - 2. Cover circumferential joints with 3-inch- wide strips, of same material as insulation jacket. Secure strips with adhesive along both edges of strip. Do not staple, use extra adhesive as required.
 - 3. Overlap jacket longitudinal seams at least 1-1/2 inches. Install insulation with longitudinal seams at bottom of pipe. Clean and dry surface to receive self-sealing lap. Do not staple laps, provide extra adhesive as required.
 - a. For below ambient services, apply vapor-barrier mastic where required to maintain vapor seal.
 - 4. Cover joints and seams with tape as recommended by insulation material manufacturer to maintain vapor seal.
 - 5. Where vapor barriers are indicated, apply vapor-barrier mastic on seams and joints and at ends adjacent to duct and pipe flanges and fittings.
- M. Cut insulation in a manner to avoid compressing insulation more than 75 percent of its nominal thickness.
- N. Finish installation with systems at operating conditions. Repair joint separations and cracking due to thermal movement.
- O. Repair damaged insulation facings by applying same facing material over damaged areas. Extend patches at least 4 inches beyond damaged areas. Adhere, staple, and seal patches similar to butt joints.
- P. For above ambient services, do not install insulation to the following:
 - 1. Testing agency labels and stamps.
 - 2. Nameplates and data plates.

3.4 PENETRATIONS

- A. Insulation Installation at Interior Wall and Partition Penetrations (That Are Not Fire Rated): Install insulation continuously through walls and partitions.
- B. Insulation Installation at Fire-Rated Wall and Partition Penetrations: Install insulation continuously through penetrations of fire-rated walls and partitions. Terminate insulation at fire damper sleeves for fire-rated wall and partition penetrations. Externally insulate damper sleeves to match adjacent insulation and overlap duct insulation at least 2 inches.

1. Firestopping and fire-resistive joint sealers are specified in Division 7 Section "Through-Penetration Firestop Systems."

C. Insulation Installation at Floor Penetrations:

1. Duct: Install insulation continuously through floor penetrations that are not fire rated. For penetrations through fire-rated assemblies, terminate insulation at fire damper sleeves and externally insulate damper sleeve beyond floor to match adjacent duct insulation. Overlap damper sleeve and duct insulation at least 2 inches.
2. Pipe: Install insulation continuously through floor penetrations.
3. Seal penetrations through fire-rated assemblies according to Division 7 Section "Through-Penetration Firestop Systems."

3.5 GENERAL PIPE INSULATION INSTALLATION

- A. Requirements in this Article generally apply to all insulation materials except where more specific requirements are specified in various pipe insulation material installation articles.

B. Insulation Installation on Fittings, Valves, Strainers, Flanges, and Unions:

1. Install insulation over fittings, valves, strainers, flanges, unions, and other specialties with continuous thermal and vapor-retarder integrity, unless otherwise indicated.
2. Insulate pipe elbows using preformed fitting insulation or mitered fittings made from same material and density as adjacent pipe insulation. Each piece shall be butted tightly against adjoining piece and bonded with adhesive. Fill joints, seams, voids, and irregular surfaces with insulating cement finished to a smooth, hard, and uniform contour that is uniform with adjoining pipe insulation.
3. Insulate tee fittings with preformed fitting insulation or sectional pipe insulation of same material and thickness as used for adjacent pipe. Cut sectional pipe insulation to fit. Butt each section closely to the next and hold in place with tie wire. Bond pieces with adhesive.
4. Insulate valves using preformed fitting insulation or sectional pipe insulation of same material, density, and thickness as used for adjacent pipe. Overlap adjoining pipe insulation by not less than two times the thickness of pipe insulation, or one pipe diameter, whichever is thicker. For valves, insulate up to and including the bonnets, valve stuffing-box studs, bolts, and nuts. Fill joints, seams, and irregular surfaces with insulating cement.
5. Insulate strainers using preformed fitting insulation or sectional pipe insulation of same material, density, and thickness as used for adjacent pipe. Overlap adjoining pipe insulation by not less than two times the thickness of pipe insulation, or one pipe diameter, whichever is thicker. Fill joints, seams, and irregular surfaces with insulating cement. Insulate strainers so strainer basket flange or plug can be easily removed and replaced without damaging the insulation and jacket. Provide a removable reusable insulation cover. For below ambient services, provide a design that maintains vapor barrier.
6. Insulate flanges and unions using a section of oversized preformed pipe insulation. Overlap adjoining pipe insulation by not less than two times the thickness of pipe insulation, or one pipe diameter, whichever is thicker.
7. Cover segmented insulated surfaces with a layer of finishing cement and coat with a mastic. Install vapor-barrier mastic for below ambient services and a breather mastic

for above ambient services. Reinforce the mastic with fabric-reinforcing mesh. Trowel the mastic to a smooth and well-shaped contour.

8. Except for flexible elastomeric, install fitted PVC cover over elbows, tees, strainers, valves, flanges, and unions. Terminate ends with PVC end caps. Tape PVC covers to adjoining insulation facing using PVC tape.
 9. Label the outside insulation jacket of each union with the word "UNION." Match size and color of pipe labels.
- C. Insulate instrument connections for thermometers, pressure gages, pressure temperature taps, test connections, flow meters, sensors, switches, and transmitters on insulated pipes, vessels, and equipment. Shape insulation at these connections by tapering it to and around the connection with insulating cement and finish with finishing cement, mastic, and flashing sealant.

3.6 FLEXIBLE ELASTOMERIC INSULATION INSTALLATION

- A. Seal longitudinal seams and end joints with manufacturer's recommended adhesive to eliminate openings in insulation that allow passage of air to surface being insulated.
- B. Insulation Installation on Pipe Flanges:
1. Install pipe insulation to outer diameter of pipe flange.
 2. Make width of insulation section same as overall width of flange and bolts, plus twice the thickness of pipe insulation.
 3. Fill voids between inner circumference of flange insulation and outer circumference of adjacent straight pipe segments with cut sections of sheet insulation of same thickness as pipe insulation.
 4. Secure insulation to flanges and seal seams with manufacturer's recommended adhesive to eliminate openings in insulation that allow passage of air to surface being insulated.
- C. Insulation Installation on Pipe Fittings and Elbows:
1. Install mitered sections of pipe insulation.
 2. Secure insulation materials and seal seams with manufacturer's recommended adhesive to eliminate openings in insulation that allow passage of air to surface being insulated.
- D. Insulation Installation on Valves and Pipe Specialties:
1. Install preformed valve covers manufactured of same material as pipe insulation when available.
 2. When preformed valve covers are not available, install cut sections of pipe and sheet insulation to valve body. Arrange insulation to permit access to packing and to allow valve operation without disturbing insulation.
 3. Install insulation to flanges as specified for flange insulation application.

4. Secure insulation to valves and specialties and seal seams with manufacturer's recommended adhesive to eliminate openings in insulation that allow passage of air to surface being insulated.

3.7 FIBERGLASS INSULATION INSTALLATION

A. Insulation Installation on Straight Pipes and Tubes:

1. Secure each layer of preformed pipe insulation to pipe with wire or bands and tighten bands without deforming insulation materials.
2. Where vapor barriers are indicated, seal longitudinal seams, end joints, and protrusions with vapor-barrier mastic and joint sealant.
3. For insulation with factory-applied jackets on above ambient surfaces, secure laps with extra adhesive as necessary. Staples are not allowed.
4. For insulation with factory-applied jackets on below ambient surfaces, do not staple longitudinal tabs but secure tabs with additional adhesive as recommended by insulation material manufacturer and seal with vapor-barrier mastic and flashing sealant.

B. Insulation Installation on Pipe Flanges:

1. Install preformed pipe insulation to outer diameter of pipe flange.
2. Make width of insulation section same as overall width of flange and bolts, plus twice the thickness of pipe insulation.
3. Fill voids between inner circumference of flange insulation and outer circumference of adjacent straight pipe segments with fiberglass blanket insulation.
4. Install jacket material with manufacturer's recommended adhesive, overlap seams at least 1 inch, and seal joints with flashing sealant.

C. Insulation Installation on Pipe Fittings and Elbows:

1. Install preformed sections of same material as straight segments of pipe insulation when available.
2. When preformed insulation elbows and fittings are not available, install mitered sections of pipe insulation, to a thickness equal to adjoining pipe insulation. Secure insulation materials with wire or bands.

D. Insulation Installation on Valves and Pipe Specialties:

1. Install preformed sections of same material as straight segments of pipe insulation when available.
2. When preformed sections are not available, install mitered sections of pipe insulation to valve body.
3. Arrange insulation to permit access to packing and to allow valve operation without disturbing insulation.
4. Install insulation to flanges as specified for flange insulation application.

- E. Blanket Insulation Installation on Ducts and Plenums: Secure with adhesive and mechanical fasteners.
1. Apply adhesives according to manufacturer's recommended coverage rates per unit area.
 2. Apply adhesive to entire circumference of ducts and to all surfaces of fittings and transitions.
 3. Install mechanical fasteners on sides and bottom of horizontal ducts and sides of vertical ducts as follows:
 - a. On duct sides with dimensions 18 inches and smaller, place mechanical fasteners along longitudinal centerline of duct. Space 3 inches maximum from insulation end joints, and 16 inches o.c.
 - b. On duct sides with dimensions larger than 18 inches, place mechanical fasteners 16 inches o.c. each way, and 3 inches maximum from insulation joints. Install additional mechanical fasteners to hold insulation tightly against surface at cross bracing.
 - c. Mechanical fasteners may be omitted from top surface of horizontal, rectangular ducts and plenums.
 - d. Do not overcompress insulation during installation.
 - e. Impale insulation over pins and attach speed washers.
 - f. Cut excess portion of pins extending beyond speed washers or bend parallel with insulation surface. Cover exposed pins and washers with tape matching insulation facing.
 4. For ducts and plenums with surface temperatures below ambient, install a continuous unbroken vapor barrier. Create a facing lap for longitudinal seams and end joints with insulation by removing 2 inches (50 mm) from 1 edge and 1 end of insulation segment. Secure laps to adjacent insulation section with 1/2-inch (13-mm) outward-clinching staples, 1 inch (25 mm) o.c. Install vapor barrier consisting of factory- or field-applied jacket, adhesive, vapor-barrier mastic, and sealant at joints, seams, and protrusions.
 - a. Repair punctures, tears, and penetrations with tape or mastic to maintain vapor-barrier seal.
 - b. Install vapor stops for ductwork and plenums operating below 50 deg F (10 deg C) at 18-foot (5.5-m) intervals. Vapor stops shall consist of vapor-barrier mastic applied in a Z-shaped pattern over insulation face, along butt end of insulation, and over the surface. Cover insulation face and surface to be insulated a width equal to 2 times the insulation thickness but not less than 3 inches (75 mm).
 5. Install insulation on rectangular duct elbows and transitions with a full insulation section for each surface. Install insulation on round and flat-oval duct elbows with individually mitered gores cut to fit the elbow.
 6. Insulate duct stiffeners, hangers, and flanges that protrude beyond insulation surface with 6-inch- wide strips of same material used to insulate duct. Secure on alternating sides of stiffener, hanger, and flange with pins spaced 6 inches o.c.

3.8 FIELD-APPLIED JACKET INSTALLATION

- A. Where PVC jackets are indicated, install with 1-inch overlap at longitudinal seams and end joints; for horizontal applications, install with longitudinal seams along top and bottom of tanks and vessels. Seal with manufacturer's recommended adhesive.
 - 1. Apply two continuous beads of adhesive to seams and joints, one bead under lap and the finish bead along seam and joint edge.
- B. Where metal jackets are indicated, install with 2-inch overlap at longitudinal seams and end joints. Overlap longitudinal seams arranged to shed water. Seal end joints with weatherproof sealant recommended by insulation manufacturer. Secure jacket with stainless-steel bands 12 inches o.c. and at end joints.

3.9 FINISHES

- A. Duct, Equipment, and Pipe Insulation with ASJ, or Other Paintable Jacket Material: Paint jacket with paint system identified below and as specified in Division 9 painting Sections.
 - 1. Flat Acrylic Finish: Two finish coats over a primer that is compatible with jacket material and finish coat paint. Add fungicidal agent to render fabric mildew proof.
 - a. Finish Coat Material: Interior, flat, latex-emulsion size.
- B. Flexible Elastomeric Thermal Insulation: After adhesive has fully cured, apply two coats of insulation manufacturer's recommended protective coating.
- C. Color: Final color as selected by Architect. Vary first and second coats to allow visual inspection of the completed Work.

3.10 FIELD QUALITY CONTROL

- A. All insulation applications will be considered defective Work if sample inspection reveals noncompliance with requirements. Remove defective Work.
- B. Install new insulation and jackets to replace insulation and jackets removed for inspection. Repeat inspection procedures after new materials are installed.

3.11 DUCT INSULATION SCHEDULE, GENERAL

- A. Plenums and Ducts Requiring Insulation:
 - 1. Supply air.
 - 2. Exhaust and relief ductwork located indoors, between isolation damper and penetration of building exterior.

B. Items Not Insulated:

1. Metal ducts with duct liner of sufficient thickness to comply with energy code and ASHRAE/IESNA 90.1 - 2007.
2. Factory-insulated plenums and casings.
3. Factory-insulated access panels and doors.
4. Exhaust ductwork, unless specified otherwise elsewhere.

3.12 INDOOR DUCT AND PLENUM INSULATION SCHEDULE

A. Provide continuous vapor-retarder for all installations.

B. Round and flat oval ductwork – Concealed ductwork or ductwork exposed in mechanical rooms; provide the following:

1. Fiberglass Blanket: 1-1/2 inches thick and 1.0-lb/cu. ft. nominal density.
2. Factory Applied Jacket: FSK

C. Rectangular ductwork – Concealed ductwork or ductwork exposed in mechanical rooms; provide any of the following:

1. Fiberglass Blanket: 1-1/2 inches thick and 1.0-lb/cu. ft. nominal density.
2. Factory Applied Jacket: FSK

D. Rectangular ductwork– exposed in finished areas; provide the following:

1. Fiberglass Board: 1-1/2 inches thick and 3-lb/cu. ft. nominal density.
2. Factory Applied Jacket: ASJ – White kraft paper.

E. Round and Flat Oval ductwork– exposed in finished areas; provide the following:

1. Semi-Rigid Fiberglass: 1-1/2 inches thick and 3-lb/cu. ft. nominal density.
2. Factory Applied Jacket: ASJ – White kraft paper.

3.13 EQUIPMENT INSULATION SCHEDULE

A. Provide a continuous vapor-retarder for applications where equipment surface temperatures below ambient exist.

B. Insulation materials and thicknesses are identified below. If more than one material is listed for a type of equipment, selection from materials listed is Contractor's option.

C. Insulate indoor and outdoor equipment in paragraphs below that are not factory insulated.

- D. Hot water and steam heating coils and/or portions of heating coils that are not encased in factory insulated enclosure.
 - 1. Fiberglass Blanket: 1-1/2 inches thick and 1.0-lb/cu. ft. nominal density.
 - 2. Fiberglass Board: 1-1/2 inches thick and 3-lb/cu. ft. nominal density.
 - 3. Factory Applied Jacket: FSK
 - 4. Insulation shall overlap adjacent insulation by a minimum of 2".

3.14 PIPING INSULATION SCHEDULE, GENERAL

- A. Acceptable preformed pipe and tubular insulation materials and thicknesses are identified for each piping system and pipe size range. If more than one material is listed for a piping system, selection from materials listed is Contractor's option.
- B. Items Not Insulated: Unless otherwise indicated, do not install insulation on the following:
 - 1. Fire-suppression piping.
 - 2. Chrome-plated pipes and fittings unless there is a potential for personnel injury.
- C. Provide a continuous vapor-retarder for applications where pipe surface temperatures below ambient exist.

3.15 INDOOR PIPING INSULATION SCHEDULE

- A. Domestic Cold Water:
 - 1. NPS 2 and Smaller: Insulation shall be any of the following:
 - a. Flexible Elastomeric: 1/2 inch thick.
 - b. Fiberglass, Preformed Pipe Insulation: 1/2 inch thick.
 - 2. NPS 2-1/2 and Larger: Insulation shall be the following:
 - a. Fiberglass, Preformed Pipe Insulation: 1 inch thick.
- B. Domestic Hot Water (operating temperature less than 130 deg. F.):
 - 1. All Pipe Sizes: Insulation shall be the following:
 - a. Fiberglass, Preformed Pipe Insulation: 1 inch thick.
- C. Heating-Hot-Water Supply and Return:

1. NPS 2" and Smaller: Insulation shall be the following:
 - a. Fiberglass, Preformed Pipe Insulation: 1 inch thick.
2. NPS 2-1/2" and Larger: Insulation shall be the following:
 - a. Fiberglass, Preformed Pipe Insulation: 1-1/2inch thick.

END OF SECTION 200700

SECTION 211000 – WATER BASED FIRE SUPPRESSION SYSTEMS

PART 1 - GENERAL

1.1 SUMMARY

A. Section Includes:

1. Provide all material, labor, engineering and operations for the installation of a complete and operable fire sprinkler system as shown on the Drawings and as specified herein.
2. Provide all equipment and materials including pipes, valves, fittings, sprinkler heads, pipe supports, specialties and accessories necessary for a complete and approved fire suppression system.
3. This Contractor shall be completely responsible for the design, layout, submittals, installation, testing, certification and acceptance of the fire suppression system by the IDHS Division of Fire and Building Safety.
4. This Contractor shall be responsible for any damage to the building and property of others caused by leaks in the fire sprinkler system and shall pay for the replacement or repair of damaged property.

B. Related Requirements:

1. Fire Detection and Alarm
2. Basic Mechanical Requirements
3. Basic Materials and Methods
4. Wiring shall be provided under the Electrical Division, unless otherwise indicated. The Electrical Division will provide all wiring from flow switches, supervised valves, alarm bell, etc. Coordinate for proper operation.

1.2 SUBMITTALS

A. Shop drawings for the fire sprinkler system shall be submitted to the Owner for review and approval prior to system installation and shall include all of the following:

1. System layout and riser diagram showing actual location of all components.
2. Manufacturer's product data sheets for all equipment and materials including pipes, couplings, fittings, valves, sprinkler heads, backflow preventers, fire department connections, pipe supports, specialties and accessories.
3. Hydraulic calculations including the volume of each system and zone.

B. Record drawings, hydraulic calculations and Operation and Maintenance Manuals for the fire sprinkler system shall be submitted to the Owner after the system installation is complete and shall include a record of all changes made to the system from that shown on the approved shop drawings.

C. Provide spare parts to the Owner as specified:

1. Provide spare sprinkler heads of each type and temperature rating installed on the project.
2. Provide one sprinkler wrench for each type of sprinkler head installed on the project.
3. Mount sprinkler head cabinets on wall next to main riser assembly.
4. Provide a list of sprinkler heads installed on the project in the sprinkler cabinet.
5. Specialty sprinkler heads shall include extra escutcheons, cover plates, etc.

1.3 QUALITY ASSURANCE

A. Contractor Qualifications:

1. Work shall be performed by a contractor regularly engaged in the design and installation of fire sprinkler systems.

B. Regulatory Requirements:

1. The Contractor shall assume full responsibility for compliance with all applicable codes, standards and regulations. This includes compliance for modification or extension of existing systems. All compliance deficiencies shall be corrected at no additional cost to the Owner.
2. Systems, work and materials shall comply with the applicable regulating agencies and organizations, which include, but are not limited to the following:
 - a. Indiana Department of Fire and Building Services.
 - b. National Fire Protection Association (NFPA).
 - c. Underwriters Laboratories (UL).
 - d. Factory Mutual (FM).
 - e. Purdue University.
3. Systems, work and materials shall comply with applicable codes, standards, and regulations, which include, but are not limited to the following:
 - a. Indiana Building Code.
 - b. Indiana Fire Code.
 - c. National Fire Protection Association.
4. If there is a conflict or discrepancy between the referenced codes, standards or regulations and the Drawings and Specification, it is the Contractor's responsibility to notify the Engineer and Owner in writing prior to installation.
5. The Contractor shall assume full financial responsibility for compliance with all applicable codes, standards and regulations. This includes compliance for modification or extension of existing systems. All deficiencies shall be corrected at no additional cost to the Owner.

PART 2 - PRODUCTS

2.1 GENERAL

- A. All products, equipment and materials shall be new, UL listed, FM approved and installed in accordance with the manufacturer's instructions and their listing or approval.
- B. All products, equipment and materials shall be rated for the maximum working pressures involved, but not less than 175 PSI cold water pressure, unless noted otherwise.

2.2 PIPE

A. General:

- 1. Pipe shall conform to ASTM Standards.
- 2. Pipe shall have the manufacturer's name or brand, and applicable ASTM Standard marked on each length of pipe.
- 3. Pipe shall have a factory applied protective coating to provide resistance to microbiologically influenced corrosion (MIC).
- 4. Lightwall pipe is not acceptable.
- 5. Grooved couplings shall be rigid type except flexible couplings shall be used in locations where vibration attenuation and stress relief are required.

B. Schedule 40:

- 1. Black steel pipe, ASTM A135 or A53, joined by welded joints, rigid grooved couplings, or threaded joints.
- 2. Grooves shall be dimensionally compatible with the coupling.

C. Schedule 10:

- 1. Black steel pipe, ASTM A135, joined by welded joints or rigid grooved couplings.
- 2. Grooves shall be dimensionally compatible with the coupling.
- 3. Cut grooves are not acceptable.

D. The following piping shall be galvanized:

- 1. Piping exposed to weather.
- 2. Drain piping open to the atmosphere.
- 3. Piping used in a corrosive atmosphere (where noted on the Drawings).

2.3 FITTINGS

A. General:

- 1. Plain end, pressure fit type fittings are not acceptable.
- 2. Hole cut mechanical tee fittings are not acceptable.
- 3. Galvanized piping shall have galvanized fittings.
- 4. 1½" pipe and smaller shall have threaded fittings.

B. Welded:

1. Standard weight, black steel in accordance with applicable ASME and ASTM standards.
2. The branch fitting diameter shall not exceed half of the nominal pipe size.

C. Grooved Fittings:

1. Fittings shall be ductile iron, minimum 350 PSI working pressure, and in accordance with ASTM A536. 5", 6" and 8" couplings shall be a minimum of 300 psi rated pressure.
2. Fittings shall be full flow standard pattern or full flow short pattern.

D. Threaded:

1. Cast iron, Class 125 or 250, ASME B16.4.
2. Malleable iron, Class 150 or 300, ASME B16.3.

E. Flanged:

1. Cast iron, Class 125 or 250, ASME B16.1.
2. Gaskets shall be full face, 1/8" minimum thickness, and red sheet rubber.
3. Flange bolts shall be hexagon head machine bolts with heavy semi-flushed hexagon head nuts, cadmium plated, with dimensions in accordance with ASME B18.2.

F. Flexible Sprinkler Hose Fittings:

1. Flexible sprinkler hose fittings shall be either FlexHead or VicFlex.
2. Flexible sprinkler hose fittings shall only use manufacturer approved brackets.

2.4 VALVES

A. General:

1. Valves shall be the same size as the pipe size shown on the Drawings.

B. Gate Valves:

1. 1½" pipe and smaller: OS&Y, bronze, screwed.
2. 2" pipe and larger: OS&Y, resilient-seated, iron body, bronze mounted, flanged.

C. Butterfly Valves:

1. Iron body (lug-style or grooved end), 300 PSI working pressure, and gear operator with position indicator.

D. Check Valves:

1. 1½" pipe and smaller: bronze, screwed.

2. 2" pipe and larger: iron body, bronze mounted, flanged.
3. Shall be of the non-slam type, semi-steel body, bronze trim, top and bottom center guide, stainless steel spring, flanged.

E. Globe and Angle Valves (Drains and Flow Regulation):

1. 1½" pipe and smaller: bronze, renewable composition disc, screwed.
2. 2" pipe and larger: iron body, bronze mounted, renewable composition disc, flanged.

F. Straight Globe Hose Valves (Roof Manifolds and Pumped Wall Hydrants):

1. 2 1/2" straight globe valve, cast brass, 300 PSI, hose thread outlet, cap and chain. Potter-Roemer 4115 or approved equal.

2.5 SPRINKLER HEADS

A. Temperature Ratings:

1. Ordinary temperature, except where higher temperature sprinkler heads are required.
2. Sprinkler heads shall be color coded.
3. Sprinkler heads located in Electrical Switchgear Rooms shall be 212° F.

B. Sprinkler heads in finished ceilings shall be white finish recessed pendent type with adjustable two piece escutcheons, unless otherwise noted.

C. Sprinkler heads in equipment rooms, rooms without finished ceilings and unfinished spaces shall be pendent or upright as required. Heads exposed to view shall be chrome finish and heads not exposed to view shall be brass finish.

PART 3 - EXECUTION

3.1 EXAMINATION

A. Verification of Conditions:

1. Examination shall be done before design approval and fabrication. Prefabrication is done at This Contractor's risk.
2. Examine existing conditions at the project site and become familiar with conditions under which the work will be performed.
3. Verify all dimensions. Be responsible for all measurements, fitting and assembly of all work.
4. Coordinate all work and placement of components with allowable space and other trades.
5. This Contractor shall be responsible for any redesign and refabricating.

3.2 PREPARATION

A. Equipment and Materials:

1. Inspect pipe and fittings for soundness and clean all dirt and other foreign matter prior to installation. Damaged equipment and materials will be rejected.

3.3 INSTALLATION

A. General:

1. The Drawings indicate general intent and location. Install piping in the most direct and straight manner as possible.
2. Sprinkler system shall be zoned on a floor-by-floor basis. In addition, systems protecting special hazards shall be zoned separately. This project shall utilize the existing zoning.
3. Install piping high enough to permit relocation of lights without moving ceiling grid.
4. Conceal piping in finished areas unless otherwise shown on the Drawings.
5. Install vertical lines plumb and horizontal lines parallel to building lines.
6. Install horizontal piping pitched to low points and in a manner to make it possible to test and empty entire system. Provide valves at low points to facilitate system drainage.
7. Protect open pipe ends whenever work is suspended during construction to prevent foreign material from entering.
8. Install chrome plated and other finished components with care so that marring does not occur to the finish.
9. Protect piping that passes through non-sprinkler areas with fire resistive construction as required by code and approved by the Owner.

B. Connection to Utilities:

1. Contractor shall make all connections to utilities as required to install the system. All connections to utilities and their shutdown shall be arranged with the Owner.

C. Pipe Hangers and Supports:

1. Support piping from the structure above with hangers.
2. Sizing, spacing and installation shall be in accordance with NFPA 13, unless otherwise shown on the Drawings or specified herein.
3. Comply with other sections of this specification relating to Basic Mechanical Materials and Methods.

D. Pipe Sleeves:

1. Provide sleeves for pipes passing through building walls and floors.
2. The annular spaces between pipe and sleeves shall be completely sealed with caulking at both ends or shall be fire stopped where required.
3. Provide chrome plated escutcheons large enough to cover the pipe sleeve in finished areas.

E. Sprinkler Heads:

1. Install sprinkler heads in accordance with the manufacturer's instructions.
2. Coordinate location of sprinkler heads with ceiling grid, diffusers, light fixtures and other obstructions. Provide additional sprinkler heads which may be required for coordinated ceiling pattern and for centering, even though it may exceed minimum code requirements. Show actual sprinkler head locations on system layout submittal and record drawings.
3. Sprinkler head locations shown on any drawings are for general intent only. This Contractor is responsible for a system layout in accordance with code requirements and Owner specification.
4. Protect finishes against scratches, dents and discoloration. Defective items are not acceptable.
5. When a sprinkler head has been removed from the pipe for any reason, it shall not be reinstalled but replaced with a new sprinkler head.
6. Center sprinkler heads in grid or lay-in ceilings in both directions.
 - a. Exception: In rooms with an area of 150 square feet or less, sprinkler heads may be centered in the grid or tile in one direction only.
7. Provide sprinkler head guards on heads below 7'-6" above the floor or walkway or where sprinkler heads may be exposed or subject to damage.

F. Valve Supervisory Switches:

1. Provide valve supervisory switches for all water supply shut-off valves.

3.4 WET PIPE SPRINKLER SYSTEMS

A. Design Criteria:

1. System shall be hydraulically calculated to provide 0.20 GPM/ft² over the most hydraulically remote 1,500 ft², including 250 GPM hose allowance. The design area of operation shall not be decreased when allowed by NFPA 13.
2. All spaces shall be designed for Ordinary Hazard 2.

3.5 EXISTING CONSTRUCTION

A. Existing Sprinkler Systems:

1. Provide all work necessary to accommodate renovations and alterations as required to meet code requirements and this Specification.
2. Modify sprinkler system to accommodate renovations and alterations that may affect spacing, coverage, etc.
3. Relocate sprinklers and piping and provide additional sprinklers and piping to accommodate new work.
4. Relocate, offset or modify existing piping and sprinklers as required to avoid conflicts with new piping, ductwork, equipment and other work.
5. Do not reinstall old sprinkler heads. Replace with new sprinkler heads and match existing system where possible.

6. Piping and sprinkler heads shown on the Drawings and old record drawings are for general information and reference only. This Contractor shall examine the project site for verification.
7. Notify the Owner of fire sprinkler system impairment. Plan work so that the interruption is minimized. Restore system to normal working order.

3.6 PAINTING AND IDENTIFICATION

- A. Identify piping installed in this project, exposed or concealed, with a label.
- B. Piping shall be labeled close to valves, at changes in direction, at branches, at access panels, before pipes pass through the floor and at entry point into rooms; however, spacing of labels shall not exceed twenty feet. Labels shall be in contrasting colors such as black on white placed in conspicuous location subject to approval by the Owner. The label shall consist of an arrow, approximately six inches in length with the width to be determined by letter height, and an abbreviation of the service ("FL" for Fireline). The following letter sizes shall apply:
 1. Pipe under 1" diameter: Letter Size ½"
 2. Pipe 1" to 3" diameter: Letter Size 1"
 3. Pipe over 3" diameter: Letter Size 2"
- C. All exposed fire sprinkler piping shall be painted. Except in mechanical, general storage and utility areas, paint shall match interior finish or as specified by Owner. Mechanical, general storage and utility shall be painted red equal to Glidden #4520 or Rustoleum #964.

3.7 FIELD QUALITY CONTROL

- A. Sterilization:
 1. This Contractor shall sterilize all piping upstream of fire sprinkler system double check valve assembly.

3.8 CLOSEOUT ACTIVITIES

- A. Testing and Acceptance:
 1. Perform all operational and acceptance tests required by NFPA 13 and 14.
 2. All tests shall be made in the presence of the Owner's representative.
 3. Test all piping hydrostatically at not less than 200 PSI for 2 hours without loss of pressure. Retest piping that fails initial tests after correction of defective work.
 4. Make arrangements to pay for costs for all inspections by the authority having jurisdiction and obtain approval of the installation.
 5. Complete and sign Contractor's Material and Test Certificates. Include copies of the certificates in the Operations and Maintenance Manuals.
- B. Demonstration

1. When required approvals of this work have been obtained, and at time designated by the Owner, demonstrate to the Owner's personnel the operation and maintenance of the systems.
2. Demonstrate equipment, specialties, and accessories. Review operating and maintenance information.
3. Schedule demonstration with Owner with at least seven days advance notice.

END OF SECTION 211000

SECTION 221116 - DOMESTIC WATER PIPING

PART 1 - GENERAL

1.1 RELATED DOCUMENTS

- A. Drawings and general provisions of the Contract, including General and Supplementary Conditions and Division 1 Specification Sections, apply to this Section.

1.2 SUMMARY

- A. Section Includes:
 - 1. Aboveground domestic water pipes, tubes, fittings, and specialties inside the building.

1.3 SUBMITTALS

- A. Product Data: For the following products:
 - 1. Dielectric fittings.
 - 2. Pipe and fitting technical information.
 - 3. Pipe joining methods.
- B. Water Samples: Specified in "Cleaning" Article.
- C. Field quality-control reports.

1.4 QUALITY ASSURANCE

- A. Piping materials shall bear label, stamp, or other markings of specified testing agency.
- B. Comply with NSF 61 for potable domestic water piping and components.
- C. Pipe, fittings, solder, flux, etc installed in domestic water piping systems shall comply with The Reduction of Lead in Drinking Water Act and be certified Lead Free, with a weighted average of less than 0.25 percent lead content when used with respect to the wetted surfaces of pipes, pipe fittings, plumbing fittings, and fixtures, and not containing more than 0.2 percent lead when used with respect to solder and flux, in accordance with the requirements of this Law which will be in effect as of January 4, 2014.

PART 2 - PRODUCTS

2.1 PIPING MATERIALS

- A. Comply with requirements in "Piping Schedule" Article for applications of pipe, tube, fitting materials, and joining methods for specific services, service locations, and pipe sizes.

2.2 COPPER TUBE AND FITTINGS

- A. Hard Copper Tube: ASTM B 88, Type L water tube, drawn temper.
1. Wrought-Copper Solder-Joint Fittings: ASME B16.22, wrought-copper pressure fittings.
 2. Bronze Flanges: ASME B16.24, Class 150, with solder-joint ends.
 3. Copper Unions: MSS SP-123, cast-copper-alloy, hexagonal-stock body, with ball-and-socket, metal-to-metal seating surfaces, and solder-joint or threaded ends.
 4. Grooved-Joint Copper-Tube Appurtenances:
 - a. Manufacturers: Subject to compliance with requirements, provide products by one of the following:
 - 1) Anvil International.
 - 2) Victaulic Company.
 - b. Copper Grooved-End Fittings: ASTM B 75 copper tube or ASTM B 584 bronze castings.
 - c. Grooved-End-Tube Couplings: Copper-tube dimensions and design similar to AWWA C606. Include ferrous housing sections, EPDM-rubber gaskets suitable for hot and cold water, and bolts and nuts. Gasket shall be rated for domestic water service.
- B. Copper, Mechanically Formed Tee Option: For forming T-branch on copper water tube.
1. Manufacturers: Subject to compliance with requirements, provide products by one of the following:
 - a. T-DRILL Industries Inc.
 2. Mechanically extracted collars shall be formed in a continuous operation consisting of drilling a pilot hole and drawing out the tube surface to form a collar having a height of not less than three times the thickness of the branch tube wall. The collaring device shall be fully adjustable as to ensure proper tolerance and complete uniformity of the joint.
 3. The branch tube shall be notched to conform with the inner curve of the run tube and have a dimple/depth stop to ensure penetration of the branch tube into the collar is of sufficient depth for brazing and that the branch tube does not obstruct the flow in the main line tube. Dimple/depth stop will be in line with the flow of the tube and visible through the braze.

4. All joints shall be brazed in accordance with the Copper Development Association Copper Tube Handbook using BCuP series filler metal. Soft soldered joints will not be permitted. Contractor assumes responsibility for joints being installed in accordance with code and manufacturers recommendation.
5. All mechanically formed branch collars shall be listed by the National Standard Plumbing Code, I.A.M.P.O., S.B.C.C., and Underwriters Laboratory.

2.3 GALVANIZED-STEEL PIPE AND FITTINGS

- A. Galvanized-Steel Pipe: ASTM A 53/A 53M, Type E, Grade B, Standard Weight. Include ends matching joining method.
 1. Galvanized-Steel Pipe Nipples: ASTM A 733, made of ASTM A 53/A 53M or ASTM A 106/A 106M, Standard Weight, seamless steel pipe with threaded ends.
 2. Galvanized, Gray-Iron Threaded Fittings: ASME B16.4, Class 125, standard pattern.
 3. Malleable-Iron Unions: ASME B16.39, Class 150, hexagonal-stock body with ball-and-socket, metal-to-metal, bronze seating surface, and female threaded ends.]

2.4 PIPING JOINING MATERIALS

- A. Pipe-Flange Gasket Materials: AWWA C110, rubber, flat face, 1/8 inch thick or ASME B16.21, nonmetallic and asbestos free, unless otherwise indicated; full-face or ring type unless otherwise indicated.
- B. Metal, Pipe-Flange Bolts and Nuts: ASME B18.2.1, carbon steel unless otherwise indicated.
- C. Solder Filler Metals: ASTM B 32, lead-free alloys. Include water-flushable flux according to ASTM B 813. Solder and flux materials for use on domestic water systems shall contain not more than 0.2 percent lead.
- D. Brazing Filler Metals: AWS A5.8/A5.8M, BCuP Series, copper-phosphorus alloys for general-duty brazing unless otherwise indicated.

PART 3 - EXECUTION

3.1 PIPING INSTALLATION

- A. Drawing plans, schematics, and diagrams indicate general location and arrangement of domestic water piping. Indicated locations and arrangements are used to size pipe and calculate friction loss, expansion, and other design considerations. Install piping as indicated unless deviations to layout are approved on Coordination Drawings.
- B. Install shutoff valve immediately upstream of each dielectric fitting.
- C. Install domestic water piping level with 0.25 percent slope downward toward drain and plumb.

- D. Install piping concealed from view and protected from physical contact by building occupants unless otherwise indicated and except in equipment rooms and service areas.
- E. Install piping at right angles or parallel to building walls. Diagonal runs are prohibited unless specifically indicated otherwise.
- F. Install piping above accessible ceilings to allow sufficient space for ceiling panel removal, and coordinate with other services occupying that space.
- G. Install piping adjacent to equipment and specialties to allow service and maintenance.
- H. Install piping to permit valve servicing.
- I. Install nipples, unions, special fittings, and valves with pressure ratings the same as or higher than system pressure rating used in applications below unless otherwise indicated.
- J. Install piping free of sags and bends.
- K. Install fittings for changes in direction and branch connections.
- L. Install unions in copper tubing at final connection to each piece of equipment, machine, and specialty.

3.2 JOINT CONSTRUCTION

- A. Ream ends of pipes and tubes and remove burrs. Bevel plain ends of steel pipe.
- B. Remove scale, slag, dirt, and debris from inside and outside of pipes, tubes, and fittings before assembly.
- C. Threaded Joints: Thread pipe with tapered pipe threads according to ASME B1.20.1. Cut threads full and clean using sharp dies. Ream threaded pipe ends to remove burrs and restore full ID. Join pipe fittings and valves as follows:
 - 1. Apply appropriate tape or thread compound to external pipe threads.
 - 2. Damaged Threads: Do not use pipe or pipe fittings with threads that are corroded or damaged.
- D. Brazed Joints: Join copper tube and fittings according to CDA's "Copper Tube Handbook," "Braze Joints" Chapter.
- E. Soldered Joints: Apply ASTM B 813, water-flushable flux to end of tube. Join copper tube and fittings according to ASTM B 828 or CDA's "Copper Tube Handbook."

- F. Extruded-Tee Connections: Form tee in copper tube according to ASTM F 2014. Use tool designed for copper tube; drill pilot hole, form collar for outlet, dimple tube to form seating stop, and braze branch tube into collar.
- G. Copper-Tubing Grooved Joints: Roll groove end of tube. Assemble coupling with housing, gasket, lubricant, and bolts. Join copper tube and grooved-end fittings according to AWWA C606 for roll-grooved joints.
- H. Flanged Joints: Select appropriate asbestos-free, nonmetallic gasket material in size, type, and thickness suitable for domestic water service. Join flanges with gasket and bolts according to ASME B31.9.
- I. Dissimilar-Material Piping Joints: Make joints using adapters compatible with materials of both piping systems. Refer to Section 200500.
- J. Provide escutcheons. Refer to Section 200500.

3.3 VALVE INSTALLATION

- A. General-Duty Valves: Comply with requirements in Division 20 Section "General-Duty Valves for Plumbing Piping" for valve installations.
- B. Install shutoff valve close to water main on each branch and riser serving plumbing fixtures or equipment, on each water supply to equipment, and on each water supply to plumbing fixtures that do not have supply stops. Use ball or gate valves for piping NPS 2 and smaller. Use butterfly or gate valves for piping NPS 2-1/2 and larger.
- C. Install drain valves for equipment at base of each water riser, at low points in horizontal piping, and where required to drain water piping. Drain valves are specified in Division 22 Section "Domestic Water Piping Specialties."
 - 1. Hose-End Drain Valves: At low points in water mains, risers, and branches.

3.4 DIELECTRIC FITTING INSTALLATION

- A. Install dielectric fittings in piping at connections of dissimilar metal piping and tubing. Refer to Section 200500.

3.5 HANGER AND SUPPORT INSTALLATION

- A. Comply with requirements in Division 20 Section "Hangers and Supports" for pipe hanger and support products and installation.
- B. Support vertical piping and tubing at base and at each floor.
- C. Rod diameter may be reduced one size for double-rod hangers, to a minimum of 3/8 inch.

- D. Install supports for vertical copper tubing every 10 feet.

3.6 CONNECTIONS

- A. Drawings indicate general arrangement of piping, fittings, and specialties.
- B. Install piping adjacent to equipment and machines to allow service and maintenance.
- C. Connect domestic water piping to water-service piping with shutoff valve; extend and connect to the following:
 - 1. Plumbing Fixtures: Cold- and hot-water supply piping in sizes indicated, but not smaller than required by plumbing code. Comply with requirements in Division 22 plumbing fixture Sections for connection sizes.
 - 2. Equipment: Cold- and hot-water supply piping as indicated, but not smaller than equipment connections. Provide shutoff valve and union for each connection. Use flanges instead of unions for NPS 2-1/2 and larger.

3.7 ESCUTCHEON INSTALLATION

- A. Install escutcheons for penetrations of walls, ceilings, and floors. Refer to Section 200500.

3.8 IDENTIFICATION

- A. Identify system components. Comply with requirements in Division 20 Section "Mechanical Identification" for identification materials and installation.
- B. Label pressure piping with system operating pressure.

3.9 FIELD QUALITY CONTROL

- A. Perform tests and inspections.
- B. Piping Inspections:
 - 1. Do not enclose, cover, or put piping into operation until it has been inspected and approved by authorities having jurisdiction.
 - 2. During installation, notify authorities having jurisdiction at least one day before inspection must be made. Perform tests specified below in presence of authorities having jurisdiction:
 - a. Roughing-in Inspection: Arrange for inspection of piping before concealing or closing-in after roughing-in and before setting fixtures.
 - b. Final Inspection: Arrange final inspection for authorities having jurisdiction to observe tests specified below and to ensure compliance with requirements.

3. Reinspection: If authorities having jurisdiction find that piping will not pass tests or inspections, make required corrections and arrange for reinspection.
4. Reports: Prepare inspection reports and have them signed by authorities having jurisdiction.

C. Piping Tests:

1. Fill domestic water piping. Check components to determine that they are not air bound and that piping is full of water.
2. Test for leaks and defects in new piping and parts of existing piping that have been altered, extended, or repaired. If testing is performed in segments, submit a separate report for each test, complete with diagram of portion of piping tested.
3. Leave new, altered, extended, or replaced domestic water piping uncovered and unconcealed until it has been tested and approved. Expose work that was covered or concealed before it was tested.
4. Refer to Division 20 Section "Basic Piping Materials and Methods" for pipe testing requirements.
5. Repair leaks and defects with new materials and retest piping or portion thereof until satisfactory results are obtained.
6. Prepare reports for tests and for corrective action required.

D. Domestic water piping will be considered defective if it does not pass tests and inspections.

E. Prepare test and inspection reports.

3.10 ADJUSTING

A. Perform the following adjustments before operation:

1. Close drain valves, hydrants, and hose bibbs.
2. Open shutoff valves to fully open position.
3. Open throttling valves to proper setting.
4. Remove plugs used during testing of piping and for temporary sealing of piping during installation.
5. Remove and clean strainer screens. Close drain valves and replace drain plugs.
6. Remove filter cartridges from housings and verify that cartridges are as specified for application where used and are clean and ready for use.
7. Check plumbing specialties and verify proper settings, adjustments, and operation.

3.11 CLEANING

A. Clean and disinfect potable and non-potable domestic water piping as follows:

1. Purge new piping and parts of existing piping that have been altered, extended, or repaired before using.
2. Use purging and disinfecting procedures prescribed by authorities having jurisdiction; if methods are not prescribed, use procedures described in either AWWA C651 or AWWA C652 or follow procedures described below:

- a. Flush piping system with clean, potable water until dirty water does not appear at outlets.
- b. Fill and isolate system according to either of the following:
 - 1) Fill system or part thereof with water/chlorine solution with at least 50 ppm of chlorine. Isolate with valves and allow to stand for 24 hours.
 - 2) Fill system or part thereof with water/chlorine solution with at least 200 ppm of chlorine. Isolate and allow to stand for three hours.
- c. Flush system with clean, potable water until no chlorine is in water coming from system after the standing time.
- d. Submit water samples in sterile bottles to authorities having jurisdiction. Repeat procedures if biological examination shows contamination.

B. Prepare and submit reports of purging and disinfecting activities.

C. Clean interior of domestic water piping system. Remove dirt and debris as work progresses.

3.12 PIPING SCHEDULE

A. Transition and special fittings with pressure ratings at least equal to piping rating may be used in applications below unless otherwise indicated.

B. Flanges and unions may be used for aboveground piping joints unless otherwise indicated.

C. Fitting Option: Extruded-tee connections and brazed joints may be used on aboveground copper tubing.

D. Aboveground domestic water piping, NPS 2 and smaller, shall be one of the following:

- 1. Hard copper tube, ASTM B 88, Type L; wrought- copper solder-joint fittings; and soldered joints.
- 2. Galvanized steel pipe and threaded galvanized fittings.

E. Aboveground domestic water piping, NPS 2-1/2 to NPS 4, shall be one of the following:

- 1. Hard copper tube, ASTM B 88, Type L; wrought- copper solder-joint fittings; and soldered joints.
- 2. Hard copper tube, ASTM B 88, Type L; grooved-joint copper-tube appurtenances; and grooved joints.

END OF SECTION 221116

SECTION 221320 – CHEMICAL RESISTANT WASTE AND VENT PIPING

PART 1 – GENERAL

1.1 RELATED DOCUMENTS

- A. Drawings and general provisions of the Contract, including General and Supplementary Conditions and Division 1 Specification Sections, apply to this Section.

1.2 SUMMARY

- A. This Section includes piping and specialties for the following systems:
 - 1. Chemical waste and vent, gravity-flow, non-pressure piping system designated “chemical waste.”
 - 2. Secondary containment piping, for installation over carrier piping, designated “secondary containment piping.”

1.3 DEFINITIONS

- A. PP: Polypropylene plastic.
- B. BG: Borosilicate glass.
- C. PVDF: Polyvinylidene Fluoride.

1.4 PERFORMANCE REQUIREMENTS

- A. Gravity Flow, Non-pressure Piping Pressure Rating: 10-foot head of water.

1.5 SUBMITTALS

- A. Product Data: For chemical waste piping materials, components, and specialties and for neutralization systems.

1.6 QUALITY ASSURANCE

- A. Source Limitations: Obtain pipe, fittings, and joining materials for each piping system through one source from a single manufacturer.
- B. Piping materials shall bear label, stamp, or other markings of specified testing laboratory.

- C. Comply with ASME B31.3, "Process Piping."

1.7 DELIVERY, STORAGE, AND HANDLING

- A. Deliver and store piping and specialties with sealing plugs in ends or with end protection.

PART 2 – PRODUCTS

2.1 MANUFACTURERS

- A. In other Part 2 articles where subparagraph titles below introduce lists, the following requirements apply for product selection:
 - 1. Manufacturers: Subject to compliance with requirements, provide products by the manufacturers specified.

2.2 PIPING MATERIALS

- A. Refer to Part 3 "Piping Applications" article for applications of pipe, tube, fitting, and joining materials.

2.3 PIPES, TUBES, AND FITTINGS

- A. Polypropylene:
 - 1. Acceptable Manufacturers:
 - a. Ipex Labline.
 - b. Georg Fischer.
 - c. Orion.
 - 2. Acid resistant, Schedule 40 pipe and fittings. Flame retardant polypropylene in accordance with ASTM D4101 and D635.
 - 3. Mechanical joint fittings shall be NSF listed, and be designed to lock into a machined groove on the mating piping. All fittings shall have integrally molded union connections. No metallic grab rings or clamps shall be allowed. Fittings containing EVA (ethylene vinyl acetate) are prohibited.
 - 4. Connections between polypropylene and other piping materials shall be made with Labline adapters according to manufacturer's recommendations.

2.4 SPECIALTIES

- A. Corrosion-Resistant Traps: P-trap or drum trap; NPS 1-1/2 or NPS 2, as required to match connected piping. Polypropylene to match polypropylene systems.

- B. Sink Outlets: NPS 1-1/2, with clamping device, stopper, and 7-inch-high overflow fitting. Polypropylene to match polypropylene systems.

2.2 JOINING MATERIALS

- A. Refer to Division 20 Section "Basic Piping Materials and Methods" for commonly used joining materials.
- B. Couplings: Assemblies with combination of clamps, gaskets, sleeves, and threaded or flanged parts; compatible with piping and system liquid; and made by piping manufacturer for joining system piping.
- C. Adapters and Transition Fittings: Assemblies with combination of clamps, couplings, adapters, gaskets, and threaded or flanged parts, compatible with piping and system liquid; and made for joining different piping materials.

PART 3 – EXECUTION

3.1 PIPING APPLICATIONS

- A. Above Floor Chemical Waste Piping: Use the following piping materials for each size range:
 - 1. Schedule 40 polypropylene drainage piping and mechanical joints.

3.2 PIPING INSTALLATION

- A. Refer to Division 20 Section "Basic Piping Materials and Methods" for basic piping installation.
- B. Install piping next to equipment, accessories, and specialties to allow service and maintenance.
- C. Transition and special fittings with pressure ratings at least equal to piping pressure rating may be used, unless otherwise indicated.

3.3 JOINT CONSTRUCTION

- A. Follow piping manufacturer's written instructions.
- B. Dissimilar Material Piping Joints: Make joints using adapters compatible with both system materials.

3.4 HANGER AND SUPPORT INSTALLATION

- A. Refer to Division 20 Section "Mechanical Hangers and Supports" for pipe hanger and support devices.

- B. Install supports according to Division 20 Section "Mechanical Hangers and Supports." Where manufacturers recommended maximum spacing is more stringent than those specified, provide manufacturers specified spacing.
- C. Support horizontal piping and tubing within at each fitting and coupling.
- D. Support vertical piping and tubing at base and at each floor.
- E. Support piping and tubing not listed above according to MSS SP-69 and manufacturer's written instructions.

3.5 CONNECTIONS

- A. Drawings indicate general arrangement of piping and specialties. The following are specific connection requirements.
- B. Install piping adjacent to equipment to allow service and maintenance.
- C. Connect chemical waste piping to sinks, specialties, accessories, and equipment. Use chemical-resistant coupling, adapter, or fitting as required for materials being joined.

3.6 LABELING AND IDENTIFICATION

- A. Install labeling and pipe markers on equipment and piping according to requirements in Division 20 Section "Mechanical Identification."

3.7 FIELD QUALITY CONTROL

- A. Chemical Waste Piping Inspection:
 - 1. Do not enclose, cover, or put drainage and vent piping into operation until it is inspected and approved by authorities having jurisdiction.
 - 2. During installation, notify authorities having jurisdiction at least 24 hours before inspection must be made. Perform tests specified below in presence of authorities having jurisdiction.
 - a. Roughing-in Inspection: Arrange for inspection of piping system before concealing after system roughing-in and before setting fixtures and equipment.
 - b. Final Inspection: Arrange for final inspection by authorities having jurisdiction to observe tests specified below and to ensure compliance with requirements.
 - 3. Reinspections: If authorities having jurisdiction find that piping will not pass test or inspection, make required corrections and arrange for reinspection.
 - 4. Reports: Prepare inspection reports and have them signed by authorities having jurisdiction.

3.8 CLEANING

- A. Use procedures prescribed by authorities having jurisdiction or, if not prescribed, use procedures described below:
1. Purge new piping and parts of existing piping that have been altered, extended, or repaired before using.
 2. Clean piping by flushing with potable water.

END OF SECTION 221320

SECTION 226713 - PROCESSED WATER PIPING

PART 1 - GENERAL

1.1 RELATED DOCUMENTS

- A. Drawings and general provisions of the Contract, including General and Supplementary Conditions and Division 1 Specification Sections, apply to this Section.

1.2 SUMMARY

- A. Section Includes:
 - 1. Reverse-osmosis water piping systems.
 - 2. Process Chilled-water piping systems.

1.3 SUBMITTALS

- A. Product Data: For the following products:
 - 1. Pipe and fitting technical information.
 - 2. Pipe joining methods.

1.4 QUALITY ASSURANCE

- A. Piping materials shall bear label, stamp, or other markings of specified testing agency.
- B. To ensure installation uniformity, pipe, fittings and valves shall be the product of one manufacturer.
- C. Protection:
 - 1. Pipe shall be furnished capped.
 - 2. Each fitting and valve shall be individually bagged.

PART 2 - PRODUCTS

2.1 MANUFACTURERS

- A. Subject to compliance with requirements, provide products by one of the following:
 - 1. IPEX Enpure.
 - 2. Georg Fischer.
 - 3. Orion Whiteline.

2.2 POLYPROPYLENE PIPE AND FITTINGS

- A. Materials:
 - 1. Virgin unpigmented polypropylene meeting ASTM D4101, using no plasticizers or antioxidants.

B. Pipe:

1. Schedule 80 iron pipe dimensions.
2. Pipe shall meet dimensional tolerances of ASTM D2447.

C. Fittings:

1. Schedule 80 wall thickness.
2. Working pressure: 150 psi at 73 °F.

D. Joints:

1. Socket fusion heat method conforming to ASTM D2657.

2.3 VALVES:

A. Materials:

1. Virgin unpigmented polypropylene meeting ASTM D4101, using no plasticizers or antioxidants.
2. Material shall be fully compatible with the piping system.
3. Wetted parts shall comply with NSF/ANSI 61.

B. Ball Valves:

1. IPEX VKD.
2. Seat: Teflon (PTFE).
3. Seal: Viton (FPM) O-rings.
4. Port: Full.
5. Working pressure: 150 psi at 73 °F.
6. Handle: PVC.
7. Ends: Socket union.

PART 3 - EXECUTION

3.1 PIPING INSTALLATION

- A. Drawing plans, schematics, and diagrams indicate general location and arrangement of piping. Indicated locations and arrangements are used to size pipe and calculate friction loss, expansion, and other design considerations. Install piping as indicated unless deviations to layout are approved on Coordination Drawings.
- B. Install piping concealed from view and protected from physical contact by building occupants unless otherwise indicated and except in equipment rooms and service areas.
- C. Install piping at right angles or parallel to building walls. Diagonal runs are prohibited unless specifically indicated otherwise.
- D. Install piping above accessible ceilings to allow sufficient space for ceiling panel removal, and coordinate with other services occupying that space.
- E. Install piping adjacent to equipment and specialties to allow service and maintenance.

- F. Install piping to permit valve servicing.
- G. Install piping free of sags and bends.
- H. Install fittings for changes in direction and branch connections.
- I. Install unions at final connection to each piece of equipment, machine, and specialty.

3.2 JOINT CONSTRUCTION

- A. Dissimilar-Material Piping Joints: Make joints using adapters compatible with materials of both piping systems. Refer to Section 200500.
- B. Provide escutcheons. Refer to Section 200500.

3.3 HANGER AND SUPPORT INSTALLATION

- A. Comply with requirements in Division 20 Section "Hangers and Supports" for pipe hanger and support products and installation.
- B. Rod diameter may be reduced one size for double-rod hangers, to a minimum of 3/8 inch.

3.4 ESCUTCHEON INSTALLATION

- A. Install escutcheons for penetrations of walls, ceilings, and floors. Refer to Section 200500.

3.5 IDENTIFICATION

- A. Identify system components. Comply with requirements in Division 20 Section "Mechanical Identification" for identification materials and installation.

3.6 FIELD QUALITY CONTROL

- A. Test all piping at 125 psig hydrostatic pressure for 6 hours minimum without loss of pressure.
- B. Prepare test and inspection reports.

3.7 CLEANING

- A. After piping system is installed, clean, flush and test to show a flow of uncontaminated high purity water at every outlet.

END OF SECTION 226713

SECTION 230593 – TESTING, ADJUSTING, AND BALANCING

PART 1 - GENERAL

1.1 RELATED DOCUMENTS

- A. Drawings and general provisions of the Contract, including General and Supplementary Conditions and Division 1 Specification Sections, apply to this Section.

1.2 SUMMARY

- A. This Section includes TAB to produce design objectives for the following:
 - 1. Air Systems:
 - a. Constant-volume air systems.
 - b. Air terminal units.
 - c. Terminal devices.
 - 2. Hydronic Piping Systems.
 - 3. Existing air and water systems and components as indicated on drawings, or that are affected by work performed as part of this project.
 - 4. Verifying that automatic control devices are functioning properly.
 - 5. Reporting results of activities and procedures specified in this Section.

1.3 DEFINITIONS

- A. Adjust: To regulate fluid flow rate and air patterns at the terminal equipment, such as to reduce fan speed or adjust a damper.
- B. Balance: To proportion flows within the distribution system, including submains, branches, and terminals, according to indicated quantities.
- C. Barrier or Boundary: Construction, either vertical or horizontal, such as walls, floors, and ceilings that are designed and constructed to restrict the movement of airflow, smoke, odors, and other pollutants.
- D. Draft: A current of air, when referring to localized effect caused by one or more factors of high air velocity, low ambient temperature, or direction of airflow, whereby more heat is withdrawn from a person's skin than is normally dissipated.
- E. Procedure: An approach to and execution of a sequence of work operations to yield repeatable results.

- F. Report Forms: Test data sheets for recording test data in logical order.
- G. Static Head: The pressure due to the weight of the fluid above the point of measurement. In a closed system, static head is equal on both sides of the pump.
- H. System Effect: A phenomenon that can create undesired or unpredicted conditions that cause reduced capacities in all or part of a system.
- I. System Effect Factors: Allowances used to calculate a reduction of the performance ratings of a fan when installed under conditions different from those presented when the fan was performance tested.
- J. TAB: Testing, adjusting, and balancing.
- K. Terminal: A point where the controlled medium, such as fluid or energy, enters or leaves the distribution system.
- L. Test: A procedure to determine quantitative performance of systems or equipment.
- M. Testing, Adjusting, and Balancing (TAB) Firm: The entity responsible for performing and reporting TAB procedures.

1.4 SUBMITTALS

- A. Certified TAB Reports: Submit four copies of reports prepared, as specified in this Section, on approved forms certified by TAB firm.
- B. Warranties specified in this Section.

1.5 QUALITY ASSURANCE

- A. Approved TAB contractors:
 - 1. Mechanical Systems Balance.
 - 2. Fluid Engineering Services – Johnson Controls Division.
 - 3. Total Air Balance.
 - 4. Midwest Balance.
 - 5. Fluid Dynamics.
 - 6. MGM Associates
- B. TAB Firm Qualifications: Engage a TAB firm certified by AABC or NEBB.
- C. Test and Balance Contractor shall not be owned by any of the prime contractors on this project which includes the General, Mechanical, Sheet Metal and Electrical contractors, and the Temperature Controls supplier.

- D. TAB Conference: Coordinate with the mechanical contractor and other trades as required.
- E. Certification of TAB Reports: Certify TAB field data reports. This certification includes the following:
 - 1. Review field data reports to validate accuracy of data and to prepare certified TAB reports.
- F. TAB Report Forms: Use standard forms from AABC's "National Standards for Testing and Balancing Heating, Ventilating, and Air Conditioning Systems." Or NEBB's "Procedural Standards for Testing, Adjusting, and Balancing of Environmental Systems."
- G. Instrumentation Type, Quantity, and Accuracy: As described in AABC's "National Standards for Testing and Balancing Heating, Ventilating, and Air Conditioning Systems or NEBB's "Procedural Standards for Testing, Adjusting, and Balancing of Environmental Systems," Section II, "Required Instrumentation for NEBB Certification."
- H. Instrumentation Calibration: Calibrate instruments at least every six months or more frequently if required by instrument manufacturer.
 - 1. Keep an updated record of instrument calibration that indicates date of calibration and the name of party performing instrument calibration.

1.6 PROJECT CONDITIONS

- A. Partial Owner Occupancy: Owner may occupy completed areas of building before Substantial Completion. Cooperate with Owner during TAB operations to minimize conflicts with Owner's operations.

1.7 COORDINATION

- A. Coordinate the efforts of factory-authorized service representatives for systems and equipment, HVAC controls installers, and other mechanics to operate HVAC systems and equipment to support and assist TAB activities.
- B. Notice: Provide seven days' advance notice for each test. Include scheduled test dates and times.
- C. Perform TAB after leakage and pressure tests on air and water distribution systems have been satisfactorily completed.

PART 2 - PRODUCTS (Not Applicable)

PART 3 - EXECUTION

3.1 EXAMINATION

- A. Examine the Contract Documents to become familiar with Project requirements and to discover conditions in systems' designs that may preclude proper TAB of systems and equipment.
 - 1. Contract Documents are defined in the General and Supplementary Conditions of Contract.
 - 2. Verify that balancing devices, such as test ports, gage cocks, thermometer wells, flow-control devices, balancing valves and fittings, and manual volume dampers, are required by the Contract Documents. Verify that quantities and locations of these balancing devices are accessible and appropriate for effective balancing and for efficient system and equipment operation.
- B. Examine reviewed submittal data of HVAC systems and equipment.
- C. Examine Project Record Documents described in Division 1 Section "Project Record Documents."
- D. Examine equipment performance data including fan curves. Relate performance data to Project conditions and requirements, including system effects that can create undesired or unpredicted conditions that cause reduced capacities in all or part of a system. Calculate system effect factors to reduce performance ratings of HVAC equipment when installed under conditions different from those presented when the equipment was performance tested at the factory. To calculate system effects for air systems, use tables and charts found in AMCA 201, "Fans and Systems," Sections 7 through 10; or in SMACNA's "HVAC Systems--Duct Design," Sections 5 and 6. Compare this data with the design data and installed conditions.
- E. Examine system and equipment installations to verify that they are complete and that testing, cleaning, adjusting, and commissioning specified in individual Sections have been performed.
- F. Examine system and equipment test reports.
- G. Examine HVAC system and equipment installations to verify that indicated balancing devices, such as test ports, gage cocks, thermometer wells, flow-control devices, balancing valves and fittings, and manual volume dampers, are properly installed, and that their locations are accessible and appropriate for effective balancing and for efficient system and equipment operation.
- H. Examine systems for functional deficiencies that cannot be corrected by adjusting and balancing.

- I. Examine HVAC equipment to ensure that clean filters have been installed, bearings are greased, belts are aligned and tight, and equipment with functioning controls is ready for operation.
- J. Examine terminal units, such as variable-air-volume boxes, to verify that they are accessible and their controls are connected and functioning.
- K. Examine strainers for clean screens and proper perforations.
- L. Examine heat-transfer coils for correct piping connections and for clean and straight fins.
- M. Examine equipment for installation and for properly operating safety interlocks and controls.
- N. Examine automatic temperature system components to verify the following:
 - 1. Dampers, valves, and other controlled devices are operated by the intended controller.
 - 2. Dampers and valves are in the position indicated by the controller.
 - 3. Integrity of valves and dampers for free and full operation and for tightness of fully closed and fully open positions. This includes dampers in multizone units, mixing boxes, and variable-air-volume terminals.
 - 4. Automatic modulating and shutoff valves, including two-way valves and three-way mixing and diverting valves, are properly connected.
 - 5. Temperature sensors are located to avoid adverse effects of sunlight, drafts, and cold walls.
 - 6. Sensors are located to sense only the intended conditions.
 - 7. Sequence of operation for control modes is according to the Contract Documents.
 - 8. Controller set points are set at indicated values.
 - 9. Interlocked systems are operating.
 - 10. Changeover from heating to cooling mode occurs according to indicated values.
- O. Report deficiencies discovered before and during performance of TAB procedures. Observe and record system reactions to changes in conditions. Record default set points if different from indicated values.

3.2 PREPARATION

- A. Prepare a TAB plan that includes strategies and step-by-step procedures.
- B. Complete system readiness checks and prepare system readiness reports. Verify the following:
 - 1. Permanent electrical power wiring is complete.
 - 2. Hydronic systems are filled, clean, and free of air.
 - 3. Automatic temperature-control systems are operational.
 - 4. Equipment and duct access doors are securely closed.
 - 5. Balance and fire dampers are open.
 - 6. Isolating and balancing valves are open and control valves are operational.
 - 7. Ceilings are installed in critical areas where air-pattern adjustments are required and access to balancing devices is provided.

8. Windows and doors can be closed so indicated conditions for system operations can be met.

3.3 GENERAL PROCEDURES FOR TESTING AND BALANCING

- A. Perform testing and balancing procedures on each system according to the procedures contained in AABC's "National Standards for Testing and Balancing Heating, Ventilating, and Air Conditioning Systems" or NEBB's "Procedural Standards for Testing, Adjusting, and Balancing of Environmental Systems" and this Section.
- B. Cut insulation, ducts, pipes, and equipment cabinets for installation of test probes to the minimum extent necessary to allow adequate performance of procedures. After testing and balancing, close probe holes and patch insulation with new materials identical to those removed. Restore vapor barrier and finish according to insulation Specifications for this Project.
- C. Mark equipment and balancing device settings with paint or other suitable, permanent identification material, including damper-control positions, valve position indicators, fan-speed-control levers, and similar controls and devices, to show final settings.
- D. Take and report testing and balancing measurements in inch-pound (IP) units.

3.4 PROCEDURES FOR BALANCING AIR SYSTEMS

- A. Prepare test reports for both fans and outlets. Obtain manufacturer's outlet factors and recommended testing procedures. Crosscheck the summation of required outlet volumes with required fan volumes.
- B. Prepare schematic diagrams of systems' "as-built" duct layouts.
- C. Determine the best locations in main and branch ducts for accurate duct airflow measurements.
- D. Check airflow patterns from the outside-air louvers and dampers and the return- and exhaust-air dampers, through the supply-fan discharge and mixing dampers.
- E. Locate start-stop and disconnect switches, electrical interlocks, and motor starters.
- F. Verify that motor starters are equipped with properly sized thermal protection.
- G. Check dampers for proper position to achieve desired airflow path.
- H. Check for airflow blockages.
- I. Check for proper sealing of air duct system.

- J. Adjust fans to deliver total indicated airflows within the maximum allowable fan speed listed by fan manufacturer.
1. Measure fan static pressures to determine actual static pressure as follows:
 - a. Measure outlet static pressure as far downstream from the fan as practicable and upstream from restrictions in ducts such as elbows and transitions.
 - b. Measure static pressure directly at the fan outlet or through the flexible connection.
 - c. Measure inlet static pressure of single-inlet fans in the inlet duct as near the fan as possible, upstream from flexible connection and downstream from duct restrictions.
 - d. Measure inlet static pressure of double-inlet fans through the wall of the plenum that houses the fan.
 2. Compare design data with installed conditions to determine variations in design static pressures versus actual static pressures. Compare actual system effect factors with calculated system effect factors to identify where variations occur. Recommend corrective action to align design and actual conditions.
 3. Obtain approval from Architect for adjustment of fan speed higher or lower than indicated speed. Make required adjustments to pulley sizes, motor sizes, and electrical connections to accommodate fan-speed changes.
 4. Do not make fan-speed adjustments that result in motor overload. Consult equipment manufacturers about fan-speed safety factors. Modulate dampers and measure fan-motor amperage to ensure that no overload will occur.
 5. Fan speed adjustment of belt drive fans shall be made by sheave and belt changes. Do not adjust airflow by limiting variable frequency drive speed.
- K. Adjust volume dampers for main duct, submain ducts, and major branch ducts to indicated airflows within specified tolerances.
1. Measure static pressure at a point downstream from the balancing damper and adjust volume dampers until the proper static pressure is achieved.
 - a. Where sufficient space in submain and branch ducts is unavailable for Pitot-tube traverse measurements, measure airflow at terminal outlets and inlets and calculate the total airflow for that zone.
 2. Remeasure each submain and branch duct after all have been adjusted. Continue to adjust submain and branch ducts to indicated airflows within specified tolerances.
- L. Measure terminal outlets and inlets (supply, return, exhaust, outside air, etc.) without making adjustments.
1. Measure terminal outlets using a direct-reading hood or outlet manufacturer's written instructions and calculating factors.
- M. Adjust terminal outlets and inlets (supply, return, exhaust, outside air, etc.) for each space to indicated airflows within specified tolerances of indicated values. Make adjustments using volume dampers rather than extractors and the dampers at air terminals.

1. Adjust each outlet in same room or space to within specified tolerances of indicated quantities without generating noise levels above the limitations prescribed by the Contract Documents.
2. Adjust patterns of adjustable outlets for proper distribution without drafts.

3.5 GENERAL PROCEDURES FOR HYDRONIC SYSTEMS

- A. Prepare test reports with pertinent design data and number in sequence starting at pump to end of system. Check the sum of branch-circuit flows against approved pump flow rate. Correct variations that exceed plus or minus 5 percent.
- B. Prepare schematic diagrams of systems' "as-built" piping layouts.
- C. Prepare hydronic systems for testing and balancing according to the following, in addition to the general preparation procedures specified above:
 1. Open all manual valves for maximum flow.
 2. Check expansion tank liquid level.
 3. Check makeup-water-station pressure gage for adequate pressure for highest vent.
 4. Check flow-control valves for specified sequence of operation and set at indicated flow.
 5. Set differential-pressure control valves at the specified differential pressure. Do not set at fully closed position when pump is positive-displacement type unless several terminal valves are kept open.
 6. Set system controls so automatic valves are wide open to heat exchangers.
 7. Check pump-motor load. If motor is overloaded, throttle main flow-balancing device so motor nameplate rating is not exceeded.
 8. Check air vents for a forceful liquid flow exiting from vents when manually operated.

3.6 PROCEDURES FOR HYDRONIC SYSTEMS

- A. Measure water flow at pumps. Use the following procedures, except for positive-displacement pumps:
 1. Verify impeller size by operating the pump with the discharge valve closed. Read pressure differential across the pump. Convert pressure to head and correct for differences in gage heights. Note the point on manufacturer's pump curve at zero flow and verify that the pump has the intended impeller size.
 2. Check system resistance. With all valves open, read pressure differential across the pump and mark pump manufacturer's head-capacity curve. Adjust pump discharge valve until indicated water flow is achieved.
 - a. Do not restrict the discharge balance valve on pumps with variable frequency drives. Adjust flow by limiting variable frequency drive speed.
 3. Verify pump-motor brake horsepower. Calculate the intended brake horsepower for the system based on pump manufacturer's performance data. Compare calculated brake horsepower with nameplate data on the pump motor. Report conditions where actual amperage exceeds motor nameplate amperage.

4. Report flow rates that are not within plus or minus 5 percent of design.
- B. Set calibrated balancing valves, if installed, at calculated presettings.
- C. Measure flow at all stations and adjust, where necessary, to obtain first balance.
 1. System components that have Cv rating or an accurately cataloged flow-pressure-drop relationship may be used as a flow-indicating device.
- D. Measure flow at main balancing station and set main balancing device to achieve flow that is 5 percent greater than indicated flow.
- E. Adjust balancing stations to within specified tolerances of indicated flow rate as follows:
 1. Determine the balancing station with the highest percentage over indicated flow.
 2. Adjust each station in turn, beginning with the station with the highest percentage over indicated flow and proceeding to the station with the lowest percentage over indicated flow.
 3. Record settings and mark balancing devices.
- F. Measure pump flow rate and make final measurements of pump amperage, voltage, rpm, pump heads, and systems' pressures and temperatures including outdoor-air temperature.
- G. Measure the differential-pressure control valve settings existing at the conclusions of balancing.

3.7 PROCEDURES FOR MOTORS

- A. Motors, 1/2 HP and Larger: Test at final balanced conditions and record the following data:
 1. Manufacturer, model, and serial numbers.
 2. Motor horsepower rating.
 3. Motor rpm.
 4. Efficiency rating.
 5. Nameplate and measured voltage, each phase.
 6. Nameplate and measured amperage, each phase.
 7. Starter thermal-protection-element rating.

3.8 PROCEDURES FOR HEAT-TRANSFER COILS

- A. Water Coils: Measure the following data for each coil:
 1. Entering- and leaving-water temperature.
 2. Water flow rate.
 3. Water pressure drop.
 4. Dry-bulb temperature of entering and leaving air.
 5. Wet-bulb temperature of entering and leaving air for cooling coils.

6. Airflow.
7. Air pressure drop.

3.9 PROCEDURES FOR LABORATORY FUME HOODS

- A. Balance the fume hood(s) to provide an average face velocity across the open sash of 100 FPM. Adjustment of airflow shall be made by adjusting the fan speed of the belt driven fans serving these hoods.
- B. Before performing laboratory fume hood testing, measure, adjust and record the supply airflow and airflow patterns of each supply air outlet that is located in the same room as the hood. Adjust the air outlet flow pattern to minimize turbulence and to achieve the desired airflow patterns at the face and inside the hood. Verify that adequate makeup air is available to achieve the indicated flow of the hood.
- C. Measure, adjust, and record the airflow of each laboratory fume hood by duct Pitot-tube traverse with the laboratory fume hood sash in the design open position.
- D. After balancing is complete, do the following:
 1. Measure and record the static pressure at the hood duct connection with the hood operating at indicated airflow.
 2. Measure and record the face velocity across the open sash face area. Measure the face velocity at each point in a grid pattern. Perform measurements at a maximum of 12 inches between points and between any point and the perimeter of the opening.
 - a. For laboratory fume hoods designed to maintain a constant face velocity at varying sash positions, also measure and record the face velocity at 50 and 25 percent of the design open sash position.
 - b. Calculate and report the average face velocity by averaging all velocity measurements.
 - c. Calculate and report the exhaust airflow by multiplying the calculated average face velocity by the sash open area. Compare this quantity with the exhaust airflow measured by duct Pitot-tube traverse. Report differences.
 - d. If the average face velocity is less than the indicated face velocity, retest the average face velocity and adjust hood baffles, fan drives, and other parts of the system to provide the indicated average face velocity.
 3. Check each laboratory fume hood for the capture and containment of smoke by using a hand-held emitting device. Observe the capture and containment of smoke flow pattern across the open face and inside the hood. Make adjustments necessary to achieve the desired results..
- E. ASHRAE 110 testing will be performed under a separate fume hood certification contract directly with the Owner.

- F. TAB Contractor shall be available to make adjustments as required during the testing and certification process. Coordinate and cooperate fully with the fume hood testing and certification agency.

3.10 TEMPERATURE-CONTROL VERIFICATION

- A. Verify that controllers are calibrated and commissioned.
- B. Check transmitter and controller locations and note conditions that would adversely affect control functions.
- C. Record controller settings and note variances between set points and actual measurements.
- D. Check free travel and proper operation of control devices such as damper and valve operators.
- E. Check the sequence of operation of control devices.
- F. Note operation of electric actuators using spring return for proper fail-safe operations.

3.11 TOLERANCES

- A. Set HVAC system airflow and water flow rates within the following tolerances:
 - 1. Supply, Return, and Exhaust Fans and Equipment with Fans: 0 to plus 10 percent.
 - 2. Air Outlets and Inlets: Plus or minus 5 percent.
 - 3. Heating-Water Flow Rate: Plus or minus 5 percent.
 - 4. Cooling-Water Flow Rate: Plus or minus 5 percent.
- B. In instances where set points within the tolerances above have a cascading effect on space pressurization requirements indicated, tolerances shall be reduced to achieve required pressurization.

3.12 FINAL REPORT

- A. General: Typewritten, or computer printout in letter-quality font, on standard bond paper, in three-ring binder, tabulated and divided into sections by tested and balanced systems.
- B. Include a certification sheet in front of binder signed and sealed by the certified testing and balancing engineer.
 - 1. Include a list of instruments used for procedures, along with proof of calibration.
- C. Final Report Contents: In addition to certified field report data, include the following:

1. Fan curves.
 2. Manufacturers' test data.
 3. Field test reports prepared by system and equipment installers.
 4. Other information relative to equipment performance, but do not include Shop Drawings and Product Data.
- D. General Report Data: In addition to form titles and entries, include the following data in the final report, as applicable:
1. Title page.
 2. Name and address of TAB firm.
 3. Project name.
 4. Project location.
 5. Architect's name and address.
 6. Engineer's name and address.
 7. Contractor's name and address.
 8. Report date.
 9. Signature of TAB firm who certifies the report.
 10. Table of Contents with the total number of pages defined for each section of the report. Number each page in the report.
 11. Summary of contents including the following:
 - a. Indicated versus final performance.
 - b. Notable characteristics of systems.
 - c. Description of system operation sequence if it varies from the Contract Documents.
 12. Nomenclature sheets for each item of equipment.
 13. Data for terminal units, including manufacturer, type size, and fittings.
 14. Notes to explain why certain final data in the body of reports varies from indicated values.
- E. System Diagrams: Include schematic layouts of air and hydronic distribution systems. Present each system with single-line diagram and include the following:
1. Quantities of outside, supply, return, and exhaust airflows.
 2. Water flow rates.
 3. Duct, outlet, and inlet sizes.
 4. Pipe and valve sizes and locations.
 5. Terminal units.
 6. Position of balancing devices.
- F. Fan Test Reports: For exhaust fans include the following:
1. Fan Data:
 - a. System identification.
 - b. Location.
 - c. Make and type.
 - d. Model number and size.

- e. Manufacturer's serial number.
 - f. Arrangement and class.
 - g. Sheave make, size in inches, and bore.
 - h. Sheave dimensions, center-to-center, and amount of adjustments in inches.
 2. Motor Data:
 - a. Make and frame type and size.
 - b. Horsepower and rpm.
 - c. Volts, phase, and hertz.
 - d. Full-load amperage and service factor.
 - e. Sheave make, size in inches, and bore.
 - f. Sheave dimensions, center-to-center, and amount of adjustments in inches.
 - g. Number of belts, make, and size.
 3. Test Data (Indicated and Actual Values):
 - a. Total airflow rate in cfm, as determined by duct traverse.
 - b. Total system static pressure in inches wg.
 - c. Fan rpm.
 - d. Discharge static pressure in inches wg.
 - e. Suction static pressure in inches wg.
- G. Round and Rectangular Duct Traverse Reports: Include a diagram with a grid representing the duct cross-section and record the following:
 1. Report Data:
 - a. System and air-handling unit number.
 - b. Location and zone.
 - c. Traverse air temperature in deg F.
 - d. Duct static pressure in inches wg.
 - e. Duct size in inches.
 - f. Duct area in sq. ft..
 - g. Indicated airflow rate in cfm.
 - h. Indicated velocity in fpm.
 - i. Actual airflow rate in cfm.
 - j. Actual average velocity in fpm.
 - k. Barometric pressure in psig.
- H. Air Inlet and Outlet Reports:
 1. Unit Data:
 - a. System and air-handling unit identification.
 - b. Location and zone.
 - c. Test apparatus used.
 - d. Area served.

- e. Air-terminal-device make.
 - f. Air-terminal-device number from system diagram.
 - g. Air-terminal-device type and model number.
 - h. Air-terminal-device size.
 - i. Air-terminal-device effective area in sq. ft.
 2. Test Data (Indicated and Actual Values):
 - a. Airflow rate in cfm.
 - b. Air velocity in fpm.
 - c. Preliminary airflow rate as needed in cfm.
 - d. Preliminary velocity as needed in fpm.
 - e. Final airflow rate in cfm.
 - f. Final velocity in fpm.
 - g. Space temperature in deg F.
- I. Air Terminal Unit Reports
 1. Unit Data:
 - a. System and air-handling unit identification.
 - b. Location and zone.
 - c. Air-terminal unit tag.
 - d. Test apparatus used.
 - e. Area served.
 - f. Air-terminal unit-device make.
 - g. Air-terminal unit-device number from system diagram.
 - h. Air-terminal unit-device type and model number.
 - i. Air-terminal unit-device size.
 2. Test Data (Indicated and Actual Values):
 - a. Inlet static pressure.
 - b. Cooling (maximum) Airflow rate in cfm.
 - c. Heating (minimum) airflow rate in cfm.
 - d. Space temperature in deg F.
- J. System-Coil Reports: For reheat coils and water coils of terminal units, include the following:
 1. Unit Data:
 - a. System and air-handling unit identification.
 - b. Location and zone.
 - c. Room or riser served.
 - d. Coil make and size.
 - e. Flowmeter type.
 2. Test Data (Indicated and Actual Values):

- a. Airflow rate in cfm.
- b. Entering-water temperature in deg F.
- c. Leaving-water temperature in deg F.
- d. Water pressure drop in feet of head or psig.
- e. Entering-air temperature in deg F.
- f. Leaving-air temperature in deg F.

K. Instrument Calibration Reports:

1. Report Data:

- a. Instrument type and make.
- b. Serial number.
- c. Application.
- d. Dates of use.
- e. Dates of calibration.

3.13 ADDITIONAL TESTS

- A. Within 90 days of completing TAB, perform additional testing and balancing to verify that balanced conditions are being maintained throughout and to correct unusual conditions.
- B. Seasonal Periods: If initial TAB procedures were not performed during near-peak summer and winter conditions, perform additional testing, inspecting, and adjusting during near-peak summer and winter conditions.

3.14 WARRANTY

- A. The TAB Contractor shall provide a one year warranty, from the time of final acceptance, during which time the Engineer, at his discretion, may request a re-test or re-adjustment of any air terminal, fan, pump or other equipment as listed in the testing and balancing report. The TAB Contractor shall provide technicians to make any tests or adjustments during this period, as requested by the Engineer, at no additional cost.

END OF SECTION 230593

SECTION 230900 – HVAC INSTRUMENTATION AND CONTROLS

PART 1 - GENERAL

1.1 RELATED DOCUMENTS

- A. Drawings and general provisions of the Contract, including General and Supplementary Conditions and Division 1 Specification Sections, apply to this Section.

1.2 SUMMARY

- A. This Section includes control equipment for HVAC systems and components, including control components for terminal heating units not supplied with factory-wired controls.
- B. The Building Automation System (BAS) shall be an extension of the existing campus system. All controls and components shall be compatible with the existing system.
- C. The owner has retained the services of Siemens Building Technologies (SBT) to design, furnish and install the temperature controls for this project.
- D. Related Sections include the following:
 - 1. Division 20 Section "Thermometers and Gages" for measuring equipment that relates to this Section.
 - 2. Division 23 Section "Sequence of Operation" for requirements that relate to this Section.
 - 3. Comply with Division 26 requirements for wiring, cabling, and installation of electrical components.
- E. The Division 23 Contractor is responsible for the items indicated in the Controls Responsibility Matrix noted in the M.C. column.
- F. The Division 26 Contractor is responsible for the items indicated in the Controls Responsibility Matrix noted in the E.C. column.
- G. All electrical power wiring shall be in conduit as described in the Electrical Section of these Specifications.
- H. See the attached control drawings, and requirements shown on the drawings and specified herein, for sensor locations, operating sequences, wiring addresses, parts lists, temperature control diagrams and installation details.
- I. Refer to the below table for a matrix of owner furnished items. Owner, MC and EC responsibilities are listed to assist the Contractor in assigning work. Regardless of these listed responsibilities, the Contractor is responsible for providing a complete and operational Temperature Control System.

CONTROLS RESPONSIBILITY MATRIX								
Device	Furnished By :				Installed By :			
	Controls Installer	Owner	MC	EC	Controls Installer	Owner	MC	EC
Temperature Sensors		X				X		
Space Humidity Sensors		X				X		
Dampers, Air Handler			X				X	
Actuators		X				X		
Pressure Transmitters		X				X		
Pressure High Limit		X				X		
Control Valves, Preheat		X					X	
Control Valves, Cooling		X					X	
Thermowells		X					X	
VFDs				X				X
Relays		X				X		
Contactors				X				X
Current Switches		X				X		
Control Wire		X				X		
Control Conduit		X				X		
Power Wiring				X				X
Power Conduit				X				X
Transformers		X				X		
Transformer Panel		X				X		
Controls Panels		X				X		
Backplane		X				X		
DDC Controllers		X				X		
Wire Duct		X				X		
Control Module Wiring		X				X		
TEC Programming		X				X		
Unit Programming		X				X		

J. Existing Controls:

1. Make modifications and alterations to existing TC system as required including:
 - a. Relocation of existing control components, devices, tubing, wiring, and conduit where affected by building renovations.
 - b. Removal of existing control components, devices, tubing, wiring and conduit.
 - c. Programming and software changes, including graphical interfaces, schedules and alarms.
 - d. All other modifications and alterations required to accommodate new work.
2. Demolition:
 - a. Remove existing control components, devices, tubing, wiring and conduit which do not remain as part of the TC system.
 - b. Turn over to Owner, those items he desires to retain. All other materials shall become property of the Contractor to dispose of properly.
3. Direct Digital Control (DDC) System:
 - a. Notify the Owner in writing prior to disconnecting, removing or reinstalling existing live DDC system components and devices, and obtain proper instruction from the Owner. If the Owner is not properly notified, the TC Contractor shall be responsible for all costs to repair damage to the DDC system.
 - b. Owner shall disconnect and remove DDC system controls and wiring. This work shall not be performed by other trades. Owner shall verify and coordinate demolition schedule with the General Contractor and be on-site at the appropriate times.
 - c. Contractor shall maintain the integrity and continuity of existing DDC system wiring and communication networks that remain.
 - d. Contractor shall be responsible to troubleshoot and repair any damage to the DDC system and communications network, including all costs.
4. Where existing controls are indicated to be re-used, test and calibrate for proper operation. If controls to be re-used are found to be defective, report immediately to the Engineer.

1.3 DEFINITIONS

- A. DDC: Direct digital control.
- B. I/O: Input/output.
- C. MS/TP: Master slave/token passing.
- D. PID: Proportional plus integral plus derivative.
- E. RTD: Resistance temperature detector.

1.4 SYSTEM PERFORMANCE

- A. Comply with the following performance requirements:

1. Object Command: Reaction time of less than two seconds between operator command of a binary object and device reaction.
2. Object Scan: Transmit change of state and change of analog values to control units or workstation within six seconds.
3. Alarm Response Time: Annunciate alarm at workstation within 45 seconds. Multiple workstations must receive alarms within five seconds of each other.
4. Program Execution Frequency: Run capability of applications as often as five seconds, but selected consistent with mechanical process under control.
5. Performance: Programmable controllers shall execute DDC PID control loops, and scan and update process values and outputs at least once per second.
6. Reporting Accuracy and Stability of Control: Report values and maintain measured variables within tolerances as follows:
 - a. Space Temperature: Plus or minus 1 deg F.
 - b. Temperature Differential: Plus or minus 0.25 deg F.
 - c. Airflow (Terminal): Plus or minus 10 percent of full scale.
 - d. Electrical: Plus or minus 5 percent of reading.

1.5 SUBMITTALS

- A. Product Data: Include manufacturer's technical literature for each control device. Indicate dimensions, capacities, performance characteristics, electrical characteristics, finishes for materials, and installation and startup instructions for each type of product indicated.
 1. DDC System Hardware: Bill of materials of equipment indicating quantity, manufacturer, and model number. Include technical data for operator workstation equipment, interface equipment, control units, transducers/transmitters, sensors, actuators, valves, relays/switches, control panels, and operator interface equipment.
 2. Controlled Systems: Instrumentation list with element name, type of device, manufacturer, model number, and product data. Include written description of sequence of operation including schematic diagram.
- B. Shop Drawings: Detail equipment assemblies and indicate dimensions, weights, loads, required clearances, method of field assembly, components, and location and size of each field connection.
 1. Bill of materials of equipment indicating quantity, manufacturer, and model number.
 2. Schematic flow diagrams showing fans, pumps, coils, dampers, valves, and control devices.
 3. Wiring Diagrams: Power, signal, and control wiring.
 4. Details of control panel faces, including controls, instruments, and labeling.
 5. Written description of sequence of operation.
 6. Schedule of dampers including size, leakage, and flow characteristics.
 7. Schedule of valves including flow characteristics.
 8. DDC System Hardware:
 - a. Wiring diagrams for control units with termination numbers.
 - b. Schematic diagrams for control, communication, and power wiring, showing trunk data conductors and wiring between operator workstation and control unit locations.

9. Controlled Systems:
 - a. Schematic diagrams of each controlled system with control points labeled and control elements graphically shown, with wiring.
 - b. Written description of sequence of operation including schematic diagram.
 - c. Points list.
- C. Field quality-control test reports.
- D. Operation and Maintenance Data: For HVAC instrumentation and control system to include in emergency, operation, and maintenance manuals. In addition to items specified in Division 1 Section "Operation and Maintenance Data," include the following:
 1. Maintenance instructions and lists of spare parts for each type of control device.
 2. Interconnection wiring diagrams with identified and numbered system components and devices.
 3. Keyboard illustrations and step-by-step procedures indexed for each operator function.
 4. Inspection period, cleaning methods, cleaning materials recommended, and calibration tolerances.
 5. Calibration records and list of set points.

1.6 QUALITY ASSURANCE

- A. Manufacturer Qualifications:
 1. Materials and equipment shall be the standard products of manufacturers regularly engaged in production and installation of automatic TC systems and shall be manufacturer's latest standard design that complies with the specification requirements.
- B. Contractor Qualifications:
 1. Contractor shall have a minimum of 10 years of experience in the design and installation of TC systems equal in scope and size to that herein specified.
 2. System shall be designed, installed, commissioned and serviced by competent, fully trained personnel.
- C. Source Limitations:
 1. All temperature controls shall be substantially of one manufacturer, furnished and installed by a single source responsibility.
 2. The TC system shall be furnished and installed by the controls manufacturer or by the manufacturer's authorized installer.
- D. Electrical Components, Devices, and Accessories: Listed and labeled as defined in NFPA 70, Article 100, by a testing agency acceptable to authorities having jurisdiction, and marked for intended use.

1.7 DELIVERY, STORAGE, AND HANDLING

- A. Factory-Mounted Components: Where control devices specified in this Section are indicated to be factory mounted on equipment, arrange for shipping of control devices to equipment manufacturer.

1.8 COORDINATION

- A. Coordinate location of temperature sensors, and other exposed control sensors with plans and room details before installation.
- B. Coordinate equipment with Division 26 Section "Panelboards" to achieve compatibility with starter coils and annunciation devices.
- C. Coordinate equipment with Division 26 Section "Motors and Motor Controllers" to achieve compatibility with motor starters and annunciation devices.
- D. Coordinate work with the Contractor and all Subcontractors for a complete and fully operational system.

PART 2 - PRODUCTS

2.1 MANUFACTURERS

- A. In other Part 2 articles where titles below introduce lists, the following requirements apply to product selection:
 - 1. Manufacturers: Subject to compliance with requirements, provide products by the manufacturer specified.

2.2 ELECTRONIC SENSORS

- A. Description: Vibration and corrosion resistant; for wall, immersion, or duct mounting as required.
- B. Thermistor Temperature Sensors and Transmitters:
 - 1. Accuracy: Plus or minus 0.5 deg F at calibration point.
 - 2. Wire: Twisted, shielded-pair cable.
 - 3. Insertion Elements in Ducts: Single point, 18 inches long; use where not affected by temperature stratification or where ducts are smaller than 9 sq. ft..
 - 4. Averaging Elements in Ducts: 72 inches long, flexible; use where prone to temperature stratification or where ducts are larger than 10 sq. ft..
- C. RTDs and Transmitters:
 - 1. Accuracy: Plus or minus 0.2 percent at calibration point.
 - 2. Wire: Twisted, shielded-pair cable.

3. Insertion Elements in Ducts: Single point, 18 inches long; use where not affected by temperature stratification or where ducts are smaller than 9 sq. ft..
4. Averaging Elements in Ducts: 24 feet long, flexible; use where prone to temperature stratification or where ducts are larger than 9 sq. ft.; length as required.

D. Room Sensor Cover Construction: Manufacturer's standard locking covers.

1. LCD display: Room temperature and setpoint.
2. Occupant setpoint adjustment.
3. Occupancy override pushbutton with indicator.

2.3 STATUS SENSORS

A. Current Switches: Self-powered, solid-state with adjustable trip current, selected to match current and system output requirements.

2.4 ACTUATORS

A. Electronic Actuators: Direct-coupled type designed for minimum 60,000 full-stroke cycles at rated torque.

1. Valves: Size for torque required for valve close off at maximum pump differential pressure.
2. Coupling: V-bolt and V-shaped, toothed cradle.
3. Overload Protection: Electronic overload or digital rotation-sensing circuitry.
4. Fail-Safe Operation: Mechanical, spring-return mechanism. Provide external, manual gear release on nonspring-return actuators.
5. Power Requirements (Two-Position Spring Return): 24-V ac.
6. Power Requirements (Modulating): Maximum 10 VA at 24-V ac or 8 W at 24-V dc.
7. Proportional Signal: 2- to 10-V dc or 4 to 20 mA, and 2- to 10-V dc position feedback signal.
8. Temperature Rating: Minus 22 to plus 122 deg F.

2.5 CONTROL VALVES

A. Control Valves: Factory fabricated, of type, body material, and pressure class based on maximum pressure and temperature rating of piping system, unless otherwise indicated.

B. Hydronic system globe valves shall have the following characteristics:

1. NPS 2 and Smaller: Class 125 bronze body, bronze trim, rising stem, renewable composition disc, and screwed ends with backseating capacity repackable under pressure.
2. Internal Construction: Replaceable plugs and stainless-steel or brass seats.
 - a. Single-Seated Valves: Cage trim provides seating and guiding surfaces for plug on top and bottom.
 - b. Double-Seated Valves: Balanced plug; cage trim provides seating and guiding surfaces for plugs on top and bottom.

3. Sizing: **5-psig** maximum pressure drop at design flow rate or the following:
 - a. Two Position: Line size.
 - b. Two-Way Modulating: Either the value specified above or twice the load pressure drop, whichever is more.
 4. Flow Characteristics: Two-way valves shall have equal percentage characteristics; three-way valves shall have linear characteristics.
 5. Close-Off (Differential) Pressure Rating: Combination of actuator and trim shall provide minimum close-off pressure rating of 150 percent of total system (pump) head for two-way valves and 100 percent of pressure differential across valve or 100 percent of total system (pump) head.
- C. Terminal Unit Control Valves: Bronze body, bronze trim, two or three ports as indicated, replaceable plugs and seats, and union and threaded ends.
1. Rating: Class 125 for service at 125 psig and 250 deg F operating conditions.
 2. Sizing: 3-psig maximum pressure drop at design flow rate, to close against pump shutoff head.
 3. Flow Characteristics: Two-way valves shall have equal percentage characteristics; three-way valves shall have linear characteristics.

2.6 TUBING

A. Copper:

1. Seamless copper tubing with soldered fittings.
2. Compression fittings may be used at connections to valve and damper operators, thermostats, and other devices where appropriate.
3. Tool made bends may be used.
4. Size: 0.25" OD minimum.

B. Polyethylene:

1. Stress crack resistant, flame retardant, plenum rated.
2. Material: 100% virgin polyethylene.
3. Color: Black.
4. Size: 0.25" OD.
5. Wall thickness: 0.04".
6. Properties:
 - a. Melt index: 0.6 g/10 min, ASTM D1238.
 - b. Density: 1.1 g/cc, ASTM D792.
 - c. Tensile strength: 2,000 psi, ASTM D638.
 - d. Elongation: 600%, ASTM D638.
 - e. Stress crack resistance: 200 hours, ASTM D1693.
 - f. Burst pressure: 500 psi at 75 °F, ASTM D1599.
 - g. Flammability: UL 94 V-2.
 - h. Smoke density – peak optical: 0.5 maximum, UL 1820.
 - i. Smoke density – average optical: 0.15 maximum, UL 1820

2.7 CONTROL WIRING AND COMMUNICATION CABLE

- A. Wiring (120V and 24V): Minimum 14 gauge. Refer to Division 26 requirements and be governed by them for temperature control wiring requirements.
- B. Communication Cables:
 - 1. Subject to compliance with requirements, the following manufacturers are acceptable:
 - a. See Temperature Control Drawings.
 - 2. Description: Multi-conductor, shielded, twisted.
 - 3. Conductor:
 - a. Stranded tinned copper or bare copper.
 - b. Communication: 18 or 24 AWG as required by control manufacturer.
 - c. Analog input and output: 18 AWG.
 - d. Digital input and output: 18 AWG.
 - 4. Insulation Material:
 - a. Non-plenum: PO or PE.
 - b. Plenum: FEP.
 - 5. Shielding: Aluminum foil-polyester tape, 100% coverage.
 - 6. Drain wire: 20 AWG stranded tinned copper.
 - 7. Jacket:
 - a. Non-plenum: PVC.
 - b. Plenum: FEP.
 - 8. Maximum operating voltage: 300 V RMS.
 - 9. UL Listed:
 - a. Non-plenum: CM.
 - b. Plenum: CMP.
 - 10. Color Coding:
 - a. Digital Output: Black 24 V, white common.
 - b. Digital Input: Black 24 V, white common.
 - c. Analog Output: Black and white power, red signal.
 - d. Analog Input: Red power, black signal.
 - e. Communication Wire: Red power, black signal.
 - 11. Wiring shall be furnished and installed in accordance with control manufacturer's requirements. Make changes necessary if manufacturer's requirements deviate from the above.
 - 12. Cable installed in air plenums shall be plenum rated.

PART 3 - EXECUTION

3.1 INSTALLATION

- A. Install software in control units and operator workstation(s). Implement all features of programs to specified requirements and as appropriate to sequence of operation.
- B. Connect and configure equipment and software to achieve sequence of operation specified.
- C. Verify location of thermostats, room temperature sensors, and other exposed control sensors with Drawings and room details before installation. Install devices 60 inches above the floor.
 - 1. Install averaging elements in ducts and plenums in crossing or zigzag pattern.
- D. Install labels and nameplates to identify control components according to Division 20 Section "Mechanical Identification."
- E. Install hydronic instrument wells, valves, and other accessories according to Division 23 Section "Hydronic Piping."

3.2 ELECTRICAL WIRING AND CONNECTION INSTALLATION

- A. Install raceways, boxes, and cabinets according to Division 26 Section "Raceways and Fittings."
- B. Install building wire and cable according to applicable Division 26 Sections.
- C. Install signal and communication cable according to Division 27 Section "Voice and Data Communication Cabling."
 - 1. Conceal cable, except in mechanical rooms and areas where other conduit and piping are exposed.
 - 2. Bundle and harness multiconductor instrument cable in place of single cables where several cables follow a common path.
 - 3. Fasten flexible conductors, bridging cabinets and doors, along hinge side; protect against abrasion. Tie and support conductors.
 - 4. Number-code or color-code conductors for future identification and service of control system, except local individual room control cables.
 - 5. Install wire and cable with sufficient slack and flexible connections to allow for vibration of piping and equipment.
- D. Connect manual-reset limit controls independent of manual-control switch positions.
- E. Connect hand-off-auto selector switches to override automatic interlock controls when switch is in hand position.

3.3 FIELD QUALITY CONTROL

- A. Manufacturer's Field Service: Engage a factory-authorized service representative to inspect, test, and adjust field-assembled components and equipment installation, including connections, and to assist in field testing. Report results in writing.

B. Perform the following field tests and inspections and prepare test reports:

1. Operational Test: After electrical circuitry has been energized, start units to confirm proper unit operation. Remove and replace malfunctioning units and retest.
2. Test and adjust controls and safeties.
3. Test calibration of controllers by disconnecting input sensors and stimulating operation with compatible signal generator.
4. Test each point through its full operating range to verify that safety and operating control set points are as required.
5. Test each control loop to verify stable mode of operation and compliance with sequence of operation. Adjust PID actions.
6. Test each system for compliance with sequence of operation.
7. Test software and hardware interlocks.

C. DDC Verification:

1. Verify that instruments are installed before calibration, testing, and loop or leak checks.
2. Check instruments for proper location and accessibility.
3. Check instrument installation for direction of flow, elevation, orientation, insertion depth, and other applicable considerations.
4. Check instrument tubing for proper fittings, slope, material, and support.
5. Check temperature instruments and material and length of sensing elements.
6. Check control valves. Verify that they are in correct direction.
7. Check DDC system as follows:
 - a. Verify that wires at control panels are tagged with their service designation and approved tagging system.
 - b. Verify that spare I/O capacity has been provided.
 - c. Verify that DDC controllers are protected from power supply surges.

D. Replace damaged or malfunctioning controls and equipment and repeat testing procedures.

3.4 ADJUSTING

A. Calibrating and Adjusting:

1. Calibrate instruments.
2. Make three-point calibration test for both linearity and accuracy for each analog instrument.
3. Calibrate equipment and procedures using manufacturer's written recommendations and instruction manuals. Use test equipment with accuracy at least double that of instrument being calibrated.
4. Control System Inputs and Outputs:
 - a. Check analog inputs at 0, 50, and 100 percent of span.
 - b. Check analog outputs using milliampere meter at 0, 50, and 100 percent output.
 - c. Check digital inputs using jumper wire.
 - d. Check digital outputs using ohmmeter to test for contact making or breaking.
 - e. Check resistance temperature inputs at 0, 50, and 100 percent of span using a precision-resistant source.
5. Temperature:

- a. Calibrate resistance temperature transmitters at 0, 50, and 100 percent of span using a precision-resistance source.
 6. Stroke and adjust control valves and dampers without positioners, following the manufacturer's recommended procedure, so that valve or damper is 100 percent open and closed.
 7. Stroke and adjust control valves and dampers with positioners, following manufacturer's recommended procedure, so that valve and damper is 0, 50, and 100 percent closed.
 8. Provide diagnostic and test instruments for calibration and adjustment of system.
 9. Provide written description of procedures and equipment for calibrating each type of instrument. Submit procedures review and approval before initiating startup procedures.
- B. Adjust initial temperature set points.
- C. Occupancy Adjustments: When requested within 12 months of date of Substantial Completion, provide on-site assistance in adjusting system to suit actual occupied conditions.

3.5 DEMONSTRATION

- A. Engage a factory-authorized service representative to train Owner's maintenance personnel to adjust, operate, and maintain HVAC instrumentation and controls. Refer to Division 1 Section "Demonstration and Training."

END OF SECTION 230900

SECTION 230993 – SEQUENCE OF OPERATION

PART 1 - GENERAL

1.1 RELATED DOCUMENTS

- A. Drawings and general provisions of the Contract, including General and Supplementary Conditions and Division 1 Specification Sections, apply to this Section.

1.2 SUMMARY

- A. This Section includes control sequences for HVAC systems, subsystems, and equipment.
- B. Related Sections include the following:
 - 1. Division 23 Section "HVAC Instrumentation and Controls" for control equipment and devices and for submittal requirements.
 - 2. Division 23 Section "Laboratory Airflow Control System".

1.3 DEFINITIONS

- A. DDC: Direct digital control.
- B. VAV: Variable air volume.

1.4 LABORATORY AIRFLOW CONTROLS

- A. Refer to Section 230960 - Laboratory Airflow Control System for sequences.

1.5 MHER-04 INDUCED DILUTION EXHAUST FAN CONTROL

- A. Fan Start/Stop:
 - 1. BAS shall start/stop fan.
 - 2. Prior to starting the fan, open outside air bypass dampers to prevent excessive duct pressure.
 - 3. Fan shall run continuously.
- B. Outside Air Bypass Dampers:
 - 1. Outside air bypass dampers and damper actuators shall be provided with the fan.
 - 2. N.C. dampers shall be closed when fan is off.
- C. Fan Isolation Dampers:
 - 1. Fan isolation damper and damper actuator shall be provided with fan.

2. 2-position, N.C. damper shall open when fan is on and close when fan is off. Hardwire damper actuator to operate with fan.
 3. Prevent fan from operating, if after a time delay on fan start-up, fan isolation damper is not proven open through damper actuator auxiliary switch.
- D. Duct Static Pressure:
1. BAS shall modulate outside air bypass dampers to maintain -1.0" w.c. to the last laboratory exhaust air valve (coordinate final setpoint with TAB Contractor).
 2. Static pressure transmitter sensor shall be located in the main exhaust air duct three- quarters distance downstream.
 3. Fan inlet high limit pressure switch with manual reset push button shall shut-down fan if pressure exceeds -3.0" w.c.

PART 2 - PRODUCTS (Not Applicable)

PART 3 - EXECUTION (Not Applicable)

END OF SECTION 230993

SECTION 232113 - HYDRONIC PIPING

PART 1 - GENERAL

1.1 RELATED DOCUMENTS

- A. Drawings and general provisions of the Contract, including General and Supplementary Conditions and Division 1 Specification Sections, apply to this Section.

1.2 SUMMARY

- A. This Section includes pipe and fitting materials, joining methods, special-duty valves, and specialties for the following:
 - 1. Hot-water heating piping.

1.3 PERFORMANCE REQUIREMENTS

- A. Hydronic piping components and installation shall be capable of withstanding the following minimum working pressure and temperature:
 - 1. Hot-Water Heating Piping: 125 psig at 250 deg F.

1.4 SUBMITTALS

- A. Product Data: For each type of the following:
 - 1. Valves. Include flow and pressure drop curves based on manufacturer's testing for calibrated-orifice balancing valves and automatic flow-control valves.
 - 2. Air control devices.
 - 3. Hydronic specialties.
- B. Field quality-control test reports.
- C. Operation and Maintenance Data: For air control devices, hydronic specialties and special-duty valves to include in emergency, operation, and maintenance manuals.

1.5 QUALITY ASSURANCE

- A. ASME Compliance: Comply with ASME B31.9, "Building Services Piping," for materials, products, and installation. Safety valves and pressure vessels shall bear the appropriate ASME

label. Fabricate and stamp air separators and expansion tanks to comply with ASME Boiler and Pressure Vessel Code: Section VIII, Division 1.

PART 2 - PRODUCTS

2.1 COPPER TUBE AND FITTINGS

- A. Drawn-Temper Copper Tubing: **ASTM B 88, Type L.**
- B. Wrought-Copper Fittings: ASME B16.22.
- C. Copper, Mechanically Formed Tee Option: For forming T-branch on copper water tube.
 - 1. Manufacturers: Subject to compliance with requirements, provide products by one of the following:
 - a. T-DRILL Industries Inc.
 - 2. Mechanically extracted collars shall be formed in a continuous operation consisting of drilling a pilot hole and drawing out the tube surface to form a collar having a height of not less than three times the thickness of the branch tube wall. The collaring device shall be fully adjustable as to ensure proper tolerance and complete uniformity of the joint.
 - 3. The branch tube shall be notched to conform with the inner curve of the run tube and have a dimple/depth stop to ensure penetration of the branch tube into the collar is of sufficient depth for brazing and that the branch tube does not obstruct the flow in the main line tube. Dimple/depth stop will be in line with the flow of the tube and visible through the braze.
 - 4. All joints shall be brazed in accordance with the Copper Development Association Copper Tube Handbook using BCuP series filler metal. Soft soldered joints will not be permitted. Contractor assumes responsibility for joints being installed in accordance with code and manufacturers recommendation.
 - 5. All mechanically formed branch collars shall be listed by the National Standard Plumbing Code, I.A.M.P.O., S.B.C.C., and Underwriters Laboratory.
- D. Wrought-Copper Unions: ASME B16.22.

2.2 JOINING MATERIALS

- A. Solder Filler Metals: ASTM B 32, lead-free alloys. Include water-flushable flux according to ASTM B 813.
- B. Brazing Filler Metals: AWS A5.8, BCuP Series, copper-phosphorus alloys for joining copper with copper; or BA9-1, silver alloy for joining copper with bronze or steel.

2.3 DIELECTRIC FITTINGS

- A. Comply with requirements listed in Division 20 Section "Common Mechanical Work Results".

2.4 VALVES

- A. Gate, Globe, Check, Ball, and Butterfly Valves: Comply with requirements specified in Division 20 Section "Valves."
- B. Automatic Temperature-Control Valves, Actuators, and Sensors: Comply with requirements specified in Division 23 Section "HVAC Instrumentation and Controls."

C. Automatic Flow-Control Valves:

1. Manufacturers: Subject to compliance with requirements, provide products by one of the following:
 - a. Flow Design Inc.
 - b. Griswold Controls.
 - c. Nexus
2. Body: Brass or ferrous metal.
3. Piston and Spring Assembly: Stainless steel, tamper proof, self cleaning, and removable.
4. Combination Assemblies: Include bronze or brass-alloy ball valve.
5. Identification Tag: Marked with zone identification, valve number, and flow rate.
6. Size: Same as pipe in which installed.
7. Performance: Maintain constant flow, plus or minus 5 percent over system pressure fluctuations.
8. Minimum CWP Rating: 300 psig.
9. Maximum Operating Temperature: 250 deg F.
10. Combination assemblies, including bronze ball valve and brass alloy control valve, with stainless-steel piston and spring, fitted with pressure and temperature test valves, and designed for 300 psig at 250 deg F.

2.5 AIR CONTROL DEVICES

- A. Manufacturers: Subject to compliance with requirements, provide products by one of the following:

1. Amtrol, Inc.
2. Bell & Gossett Domestic Pump; a division of ITT Industries.
3. Taco.

B. Manual Air Vents:

1. Body: Bronze.
2. Internal Parts: Nonferrous.

3. Operator: Screwdriver or thumbscrew.
4. Inlet Connection: **NPS 1/2**.
5. Discharge Connection: **NPS 1/8**.
6. CWP Rating: **150 psig**.
7. Maximum Operating Temperature: **225 deg F**.

2.6 HYDRONIC PIPING SPECIALTIES

A. Y-Pattern Strainers:

1. "Y" type, stainless steel screen.
2. 2" and smaller: 250 psi working pressure, threaded ends. Cast iron body for steel piping, cast bronze body for copper lines. 1/16" screen for water service.
3. 2-1/2" and larger: 125 psi working pressure or 150 percent of operating pressure, whichever is greater. 250 psi working pressure for high pressure steam (125 psi and above). Cast iron, flanged. 1/16" (.062") perforations on sizes 2-1/2" through 4" and 1/8" (.125") perforations on sizes 5" and larger for water service.

PART 3 - EXECUTION

3.1 PIPING APPLICATIONS

A. Hot-water heating piping, aboveground, **NPS 2** and smaller, shall be any of the following:

1. Type **L**, drawn-temper copper tubing, wrought-copper fittings, and brazed joints.

3.2 VALVE APPLICATIONS

- A. Install shutoff-duty valves at each branch connection to supply mains, and at supply connection to each piece of equipment.
- B. Install shutoff valves at the base of each riser; at each branch line off of riser; and wherever else indicated.
- C. Install calibrated-orifice, balancing valves in the return pipe of each heating or cooling terminal.

3.3 PIPING INSTALLATIONS

- A. Drawing plans, schematics, and diagrams indicate general location and arrangement of piping systems. Indicate piping locations and arrangements if such were used to size pipe and calculate friction loss, expansion, pump sizing, and other design considerations. Install piping as indicated.
- B. Install piping in concealed locations, unless otherwise indicated and except in equipment rooms and service areas.

- C. Install piping at right angles or parallel to building walls. Diagonal runs are prohibited unless specifically indicated otherwise.
- D. Install piping above accessible ceilings to allow sufficient space for ceiling panel removal.
- E. Install piping to permit valve servicing.
- F. Install piping at indicated slopes.
- G. Install piping free of sags and bends.
- H. Install fittings for changes in direction and branch connections.
- I. Install piping to allow application of insulation.
- J. Select system components with pressure rating equal to or greater than system operating pressure.
- K. Install groups of pipes parallel to each other, spaced to permit applying insulation and servicing of valves.
- L. Install drains, consisting of a tee fitting, **NPS 3/4** ball valve, and short **NPS 3/4** threaded nipple with cap, at low points in piping system mains and elsewhere as required for system drainage.
- M. Install piping at a uniform grade of 0.2 percent upward in direction of flow.
- N. Reduce pipe sizes using eccentric reducer fitting installed with level side up.
- O. Install branch connections to mains using tee fittings in main pipe, with the branch connected to the bottom of the main pipe. For up-feed risers, connect the branch to the top of the main pipe.
- P. Install valves according to Division 20 Section "Valves."
- Q. Install unions in piping, **NPS 2** and smaller, adjacent to valves, at final connections of equipment, and elsewhere as indicated.
- R. Install strainers on inlet side of each control valve, pressure-reducing valve, solenoid valve, in-line pump, and elsewhere as indicated. Install **NPS 3/4** nipple and ball valve in blowdown connection of strainers **NPS 2** and larger. Match size of strainer blowoff connection for strainers smaller than **NPS 2**.
- S. Branch and runout connections to heating water mains shall be made with swing joints to allow for expansion of piping.

- T. Identify piping as specified in Division 20 Section "Mechanical Identification."

3.4 HANGERS AND SUPPORTS

- A. Hanger, support, and anchor devices are specified in Division 20 Section "Mechanical Hangers and Supports." Comply with the following requirements for maximum spacing of supports.
- B. Refer to Division 20 Section "Mechanical Hangers and Supports" for maximum hanger spacing and required locations.

3.5 PIPE JOINT CONSTRUCTION

- A. Join pipe and fittings according to the following requirements and Division 23 Sections specifying piping systems.
- B. Ream ends of pipes and tubes and remove burrs. Bevel plain ends of steel pipe.
- C. Remove scale, slag, dirt, and debris from inside and outside of pipe and fittings before assembly.
- D. Soldered Joints: Apply ASTM B 813, water-flushable flux, unless otherwise indicated, to tube end. Construct joints according to ASTM B 828 or CDA's "Copper Tube Handbook," using lead-free solder alloy complying with ASTM B 32.
- E. Brazed Joints: Construct joints according to AWS's "Brazing Handbook," "Pipe and Tube" Chapter, using copper-phosphorus brazing filler metal complying with AWS A5.8.
- F. Threaded Joints: Thread pipe with tapered pipe threads according to ASME B1.20.1. Cut threads full and clean using sharp dies. Ream threaded pipe ends to remove burrs and restore full ID. Join pipe fittings and valves as follows:
 - 1. Apply appropriate tape to external pipe threads unless dry seal threading is specified.
 - 2. Damaged Threads: Do not use pipe or pipe fittings with threads that are corroded or damaged. Do not use pipe sections that have cracked or open welds.
- G. Mechanically Formed, Copper-Tube-Outlet Joints: Use manufacturer-recommended tool and procedure, and brazed joints. Installer shall be certified by the manufacturer to install this type of system.
- H. Dissimilar-Material Piping Joints: Make joints using adapters compatible with materials of both piping systems. Refer to Division 20 Section "Common Mechanical Work Results".
- I. Dissimilar-Material Piping at Valves: Make joints using adapters compatible with materials of both piping systems. Refer to Division 20 Section "Common Mechanical Work Results".

3.6 HYDRONIC SPECIALTIES INSTALLATION

- A. Install manual air vents at high points in piping, at heat-transfer coils, and elsewhere as required for system air venting.

3.7 TERMINAL EQUIPMENT CONNECTIONS

- A. Sizes for supply and return piping connections shall be the same as or larger than equipment connections.
- B. Pipe size reduction from the size shown on plans to the equipment connection size shall be made after valves and hydronic specialties.
- C. Install control valves in accessible locations close to connected equipment.
- D. Install ports for pressure gages and thermometers at coil inlet and outlet connections according to Division 20 Section "Thermometers and Gages."

3.8 FIELD QUALITY CONTROL

- A. Prepare hydronic piping according to ASME B31.9 and as follows:
 - 1. Leave joints, including welds, uninsulated and exposed for examination during test.
 - 2. Provide temporary restraints for expansion joints that cannot sustain reactions due to test pressure. If temporary restraints are impractical, isolate expansion joints from testing.
 - 3. Flush hydronic piping systems with clean water; then remove and clean or replace strainer screens.
 - 4. Isolate equipment from piping. If a valve is used to isolate equipment, its closure shall be capable of sealing against test pressure without damage to valve. Install blinds in flanged joints to isolate equipment.
 - 5. Install safety valve, set at a pressure no more than one-third higher than test pressure, to protect against damage by expanding liquid or other source of overpressure during test.
- B. Perform the following tests on hydronic piping:
 - 1. Use ambient temperature water as a testing medium unless there is risk of damage due to freezing. Another liquid that is safe for workers and compatible with piping may be used.
 - 2. While filling system, use vents installed at high points of system to release air. Use drains installed at low points for complete draining of test liquid.
 - 3. Isolate expansion tanks and determine that hydronic system is full of water.
 - 4. Subject piping system to hydrostatic test pressure that is not less than 1.5 times the system's working pressure. Test pressure shall not exceed maximum pressure for any vessel, pump, valve or other component in system under test. Verify that stress due to pressure at bottom of vertical runs does not exceed 90 percent of specified minimum yield strength or 1.7 times "SE" value in Appendix A in ASME B31.9, "Building Services Piping."

5. After hydrostatic test pressure has been applied for at least 10 minutes, examine piping, joints and connections for leakage. Eliminate leaks by tightening, repairing or replacing components, and repeat hydrostatic test until there are no leaks.
6. Prepare written report of testing.

C. Perform the following before operating the system:

1. Open manual valves fully.
2. Inspect air vents at high points of system and determine if all are installed and operating freely (automatic type), or bleed air completely (manual type).
3. Set temperature controls so all coils are calling for full flow.

END OF SECTION 232113

SECTION 233113 – METAL DUCTS

PART 1 - GENERAL

1.1 RELATED DOCUMENTS

- A. Drawings and general provisions of the Contract, including General and Supplementary Conditions and Division 1 Specification Sections, apply to this Section.

1.2 SUMMARY

- A. Section Includes:

1. Single-wall rectangular ducts and fittings.
2. Single-wall round ducts and fittings.
3. Double-wall round ducts and fittings.
4. Sheet metal materials.
5. Sealants and gaskets.
6. Hangers and supports.

- B. Related Sections:

1. Division 23 Section "Duct Accessories" for dampers, sound-control devices, duct-mounting access doors and panels, turning vanes, and flexible ducts.
2. Division 23 Section "Testing, Adjusting, and Balancing" for testing, adjusting, and balancing requirements for metal ducts.
3. Division 20 Section "Mechanical Hangers and Supports" for attachment of hangers to structure.

1.3 PERFORMANCE REQUIREMENTS

- A. Delegated Duct Design: Duct construction, including sheet metal thicknesses, seam and joint construction, reinforcements, and hangers and supports, shall comply with SMACNA's "HVAC Duct Construction Standards - Metal and Flexible" and performance requirements and design criteria indicated.

1. Static-Pressure Classes:

- a. Rectangular Supply Ducts (Variable Air Volume systems, upstream from Air Terminal Units): 4-inch wg. Seal Class A, Leakage Class 4.
- b. Round Supply Ducts (Variable Air Volume systems, upstream from Air Terminal Units): 4-inch wg. Seal Class A, Leakage Class 2.
- c. Rectangular Supply Ducts (Downstream from Air Terminal Units and Fan Coil Units): 1-inch wg., Seal Class C, Leakage Class 16

- d. Round Supply Ducts (Downstream from Air Terminal Units and Fan Coil Units): 1-inch wg. Seal Class C, Leakage Class 8.
 - e. Rectangular Laboratory Exhaust Air Ductwork (all ductwork connected to laboratory exhaust fan - negative pressure): 4-inch wg. Seal Class A, Leakage Class 4.
 - f. Round Laboratory Exhaust Air Ductwork (all ductwork connected to laboratory exhaust fan - negative pressure): 4-inch wg. Seal Class A, Leakage Class 2.
2. Structural Performance: Duct hangers and supports shall withstand the effects of gravity loads and stresses within limits and under conditions described in SMACNA's "HVAC Duct Construction Standards - Metal and Flexible"

1.4 SUBMITTALS

A. Product Data: For each type of the following products:

1. Sealants and gaskets.

B. Shop Drawings:

1. Factory- and shop-fabricated ducts and fittings.
2. Fittings.
3. Reinforcement and spacing.
4. Seam and joint construction.
5. Penetrations through fire-rated and other partitions.
6. Hangers and supports, including methods for duct and building attachment and vibration isolation.
7. Shop Drawings: CAD generated and drawn to ¼ inch equals 1 foot scale. Show fabrication and installation details for metal ducts.
 - a. Fabrication, assembly, and installation including plans, elevations, sections, components, and attachments to other work.
 - b. Duct layout indicating duct sizes and pressure class.
 - c. Elevation of top and bottom of ducts.
 - d. Dimensions of main duct runs from building grid lines.
 - e. Fittings
 - f. Reinforcement and spacing.
 - g. Seam and joint construction.
 - h. Penetrations through fire-rated and other partitions.
 - i. Equipment installation based on actual equipment being used on project.
 - j. Duct accessories, including access doors and panels.
 - k. Hangers and supports, including methods for duct and building attachment and vibration isolation.
 - l. Ceiling suspension assembly members.
 - m. All other systems installed in same space as ducts.
 - n. Ceiling and wall mounted access doors and panels required to provide access to dampers and other operating devices.
 - o. Ceiling mounted items, including light fixtures, diffusers, grilles, speakers, sprinklers, access panels and special moldings.

- C. Delegated-Design Submittal:
 - 1. Sheet metal thicknesses.
 - 2. Joint and seam construction and sealing.
 - 3. Reinforcement details and spacing.
 - 4. Materials, fabrication, assembly, and spacing of hangers and supports.
- D. Welding certificates.
- E. Field quality-control reports.

1.5 QUALITY ASSURANCE

- A. Welding Qualifications: Qualify procedures and personnel according to AWS D1.1/D1.1M, "Structural Welding Code - Steel," for hangers and supports.
- B. All duct liners, sealants, adhesives, etc. used in duct systems shall have a flame spread of no more than 25 and a smoke developed rating of not more than 50.

1.6 DELIVERY, STORAGE AND HANDLING

- A. Store all ductwork and associated ductwork components to prevent damage and to prevent entrance of dirt, debris and moisture.
- B. Support all ductwork and associated ductwork components to prevent sagging or bending.
- C. Install end caps on installed ductwork to prevent entrance of dirt, debris and moisture.

PART 2 - PRODUCTS

2.1 SINGLE-WALL RECTANGULAR DUCTS AND FITTINGS

- A. General Fabrication Requirements: Comply with SMACNA's "HVAC Duct Construction Standards - Metal and Flexible" based on indicated static-pressure class unless otherwise indicated.
- B. Transverse Joints: Select joint types and fabricate according to SMACNA's "HVAC Duct Construction Standards - Metal and Flexible," Figure 1-4, "Transverse (Girth) Joints," for static-pressure class, applicable sealing requirements, materials involved, duct-support intervals, and other provisions in SMACNA's "HVAC Duct Construction Standards - Metal and Flexible."
- C. Formed-On Flanges: Construct according to SMACNA's "HVAC Duct Construction Standards-Metal and Flexible," Figure 1-4, using corner, bolt, cleat, and gasket details.
 - 1. Manufacturers:

- a. Ductmate Industries, Inc.
 - b. Lockformer.
2. Duct Size: Maximum 30 inches wide and up to 2-inch wg pressure class.
 3. Longitudinal Seams: Pittsburgh lock sealed with non-curing polymer sealant.
- D. Longitudinal Seams: Select seam types and fabricate according to SMACNA's "HVAC Duct Construction Standards - Metal and Flexible," Figure 1-5, "Longitudinal Seams - Rectangular Ducts," for static-pressure class, applicable sealing requirements, materials involved, duct-support intervals, and other provisions in SMACNA's "HVAC Duct Construction Standards - Metal and Flexible."
- E. Elbows, Transitions, Offsets, Branch Connections, and Other Duct Construction: Select types and fabricate according to SMACNA's "HVAC Duct Construction Standards - Metal and Flexible," Chapter 2, "Fittings and Other Construction," for static-pressure class, applicable sealing requirements, materials involved, duct-support intervals, and other provisions in SMACNA's "HVAC Duct Construction Standards - Metal and Flexible."

2.2 SINGLE-WALL ROUND DUCTS AND FITTINGS

- A. General Fabrication Requirements: Comply with SMACNA's "HVAC Duct Construction Standards - Metal and Flexible," Chapter 3, "Round, Oval, and Flexible Duct," based on indicated static-pressure class unless otherwise indicated.
1. Manufacturers: Subject to compliance with requirements, provide products by one of the following:
 - a. Lindab Inc.
 - b. McGill AirFlow LLC.
 - c. SEMCO Incorporated.
 - d. LaPine.
 - e. Eastern Sheet Metal.
- B. Transverse Joints: Select joint types and fabricate according to SMACNA's "HVAC Duct Construction Standards - Metal and Flexible," Figure 3-2, "Transverse Joints - Round Duct," for static-pressure class, applicable sealing requirements, materials involved, duct-support intervals, and other provisions in SMACNA's "HVAC Duct Construction Standards - Metal and Flexible."
1. Transverse Joints in Ducts Larger Than 60 Inches in Diameter: Flanged.
- C. Spiral lock-seam Construction
1. Round ducts of pressure classification greater than 2" shall be of spiral lock-seam construction.
 2. Round ducts exposed to view shall be of spiral lock-seam construction.
 3. Longitudinal seam shall be used in those sizes for which spiral lock-seam is not available.

- D. Longitudinal Seams: Select seam types and fabricate according to SMACNA's "HVAC Duct Construction Standards - Metal and Flexible," Figure 3-1, "Seams - Round Duct and Fittings," for static-pressure class, applicable sealing requirements, materials involved, duct-support intervals, and other provisions in SMACNA's "HVAC Duct Construction Standards - Metal and Flexible."
1. Fabricate round ducts larger than 90 inches in diameter with butt-welded longitudinal seams.
- E. Tees and Laterals: Select types and fabricate according to SMACNA's "HVAC Duct Construction Standards - Metal and Flexible," Figure 3-4, "90 Degree Tees and Laterals," and Figure 3-5, "Conical Tees," for static-pressure class, applicable sealing requirements, materials involved, duct-support intervals, and other provisions in SMACNA's "HVAC Duct Construction Standards - Metal and Flexible."
- F. Fabricate elbows using die-formed, gored, pleated, or mitered construction. Centerline bend radius of die-formed, gored, and pleated elbows shall be 1-1/2 times duct diameter. Unless elbow construction type is indicated, fabricate elbows as follows:
1. Mitered-Elbow Radius and Number of Pieces: Welded construction complying with SMACNA's "HVAC Duct Construction Standards-metal and Flexible", unless otherwise indicated.
 2. Round Mitered Elbows: Welded construction with the following metal thickness for pressure classes from 2- to 10-inch wg:
 - a. Ducts 3 to 26 Inches in Diameter: 0.034 inch.
 - b. Ducts 27 to 50 Inches in Diameter: 0.040 inch.
 - c. Ducts 52 to 60 Inches in Diameter: 0.052 inch.
 - d. Ducts 62 to 84 Inches in Diameter: 0.064 inch.
 3. Round Elbows 8 Inches and Less in Diameter: Fabricate die-formed elbows for 45- and 90-degree elbows and pleated elbows for 30, 45, 60, and 90 degrees only. Fabricate nonstandard bend-angle configurations or nonstandard diameter elbows with gored construction.
 4. Round Elbows 9 through 14 Inches in Diameter: Fabricate gored or pleated elbows for 30, 45, 60, and 90 degrees unless space restrictions require mitered elbows. Fabricate nonstandard bend-angle configurations or nonstandard diameter elbows with gored construction.
 5. Round Elbows Larger than 14 Inches in Diameter: Fabricate gored elbows unless space restrictions require mitered elbows.
 6. Die-Formed Elbows for Sizes through 8 Inches in Diameter and All Pressures: 0.040 inch thick with 2-piece welded construction.
 7. Round Gored-Elbow Metal Thickness: Same as non-elbow fittings specified above.
 8. Pleated Elbows for Sizes through 14 Inches in Diameter and Pressures through 10-Inch wg: 0.022 inch.

2.3 DOUBLE-WALL ROUND DUCTS AND FITTINGS

- A. Manufacturers: Subject to compliance with requirements, provide products by one of the following:
1. Lindab Inc.
 2. McGill AirFlow LLC.
 3. SEMCO Incorporated.
 4. LaPine.
 5. Eastern Sheet Metal.
- B. Outer Duct: Comply with SMACNA's "HVAC Duct Construction Standards - Metal and Flexible," Chapter 3, "Round, Oval, and Flexible Duct," based on static-pressure class unless otherwise indicated.
1. Transverse Joints: Select joint types and fabricate according to SMACNA's "HVAC Duct Construction Standards - Metal and Flexible," Figure 3-2, "Transverse Joints - Round Duct," for static-pressure class, applicable sealing requirements, materials involved, duct-support intervals, and other provisions in SMACNA's "HVAC Duct Construction Standards - Metal and Flexible."
 - a. Transverse Joints in Ducts Larger Than 60 Inches in Diameter: Flanged.
 2. Spiral lock-seam Construction
 - a. Round ducts of pressure classification greater than 2" shall be of spiral lock-seam construction.
 - b. Round ducts exposed to view shall be of spiral lock-seam construction.
 - c. Longitudinal seam shall be used in those sizes for which spiral lock-seam is not available.
 3. Longitudinal Seams: Select seam types and fabricate according to SMACNA's "HVAC Duct Construction Standards - Metal and Flexible," Figure 3-1, "Seams - Round Duct and Fittings," for static-pressure class, applicable sealing requirements, materials involved, duct-support intervals, and other provisions in SMACNA's "HVAC Duct Construction Standards - Metal and Flexible."
 - a. Fabricate round ducts larger than 90 inches in diameter with butt-welded longitudinal seams.
 - b. Fabricate flat-oval ducts larger than 72 inches in width (major dimension) with butt-welded longitudinal seams.
 4. Tees and Laterals: Select types and fabricate according to SMACNA's "HVAC Duct Construction Standards - Metal and Flexible," Figure 3-4, "90 Degree Tees and Laterals," and Figure 3-5, "Conical Tees," for static-pressure class, applicable sealing requirements, materials involved, duct-support intervals, and other provisions in SMACNA's "HVAC Duct Construction Standards - Metal and Flexible."

- C. Inner Duct: Minimum 0.028-inch solid sheet steel.
- D. Interstitial Insulation: Fibrous-glass liner complying with ASTM C 1071, NFPA 90A, or NFPA 90B; and with NAIMA AH124, "Fibrous Glass Duct Liner Standard."
 - 1. Maximum Thermal Conductivity: 0.27 Btu x in./h x sq. ft. x deg F at 75 deg F mean temperature.
 - 2. Install spacers that position the inner duct at uniform distance from outer duct without compressing insulation.
 - 3. Coat insulation with antimicrobial coating.
 - 4. Cover insulation with polyester film complying with UL 181, Class 1.
 - 5. Thickness: 1-inch.

2.4 SHEET METAL MATERIALS

- A. General Material Requirements: Comply with SMACNA's "HVAC Duct Construction Standards - Metal and Flexible" for acceptable materials, material thicknesses, and duct construction methods unless otherwise indicated. Sheet metal materials shall be free of pitting, seam marks, roller marks, stains, discolorations, and other imperfections.
- B. Galvanized Sheet Steel: Comply with ASTM A 653/A 653M.
 - 1. Galvanized Coating Designation: G90.
 - 2. Finishes for Surfaces Exposed to View: Mill phosphatized – paintable. Provide surface suitable for field painting without flaking, or provide factory primed surface.
- C. Epoxy Coated Galvanized Steel:
 - 1. Galvanized steel ductwork shall be epoxy coated internally.
 - 2. Clean surfaces by solvent cleaning SSPC-SPI procedure.
 - 3. After cleaning apply 2 coats of Tnemec Series 66 High Build Epoxoline Epoxy - Polyamide Coating.
 - 4. Apply each coat at 4.0 mils D.F.T.
 - 5. Each section shall be painted and abrasions touched up as soon as practical after assembly.
- D. Reinforcement Shapes and Plates: ASTM A 36/A 36M, steel plates, shapes, and bars; galvanized.
- E. Tie Rods: Galvanized steel, 1/4-inch minimum diameter for lengths 36 inches or less; 3/8-inch minimum diameter for lengths longer than 36 inches.

2.5 SEALANT AND GASKETS

- A. General Sealant and Gasket Requirements: Surface-burning characteristics for sealants and gaskets shall be a maximum flame-spread index of 25 and a maximum smoke-developed index of 50 when tested according to UL 723; certified by an NRTL.

B. Two-Part Tape Sealing System:

1. Tape: Woven cotton fiber impregnated with mineral gypsum and modified acrylic/silicone activator to react exothermically with tape to form hard, durable, airtight seal.
2. Tape Width: 3 in.
3. Sealant: Modified styrene acrylic.
4. Water resistant.
5. Mold and mildew resistant.
6. Maximum Static-Pressure Class: 10-inch wg, positive and negative.
7. Service: Indoor and outdoor.
8. Service Temperature: Minus 40 to plus 200 deg F.
9. Substrate: Compatible with galvanized sheet steel (both PVC coated and bare), stainless steel, or aluminum.

C. Water-Based Joint and Seam Sealant:

1. Application Method: Brush on.
2. Solids Content: Minimum 65 percent.
3. Shore A Hardness: Minimum 20.
4. Water resistant.
5. Mold and mildew resistant.
6. VOC: Maximum 75 g/L (less water).
7. Maximum Static-Pressure Class: 10-inch wg, positive and negative.
8. Service: Indoor or outdoor.
9. Substrate: Compatible with galvanized sheet steel (both coated and bare), stainless steel, or aluminum sheets.

D. Flanged Joint Sealant: Comply with ASTM C 920.

1. General: Single-component, acid-curing, silicone, elastomeric.
2. Type: S.
3. Grade: NS.
4. Class: 25.
5. Use: O.

E. Flange Gaskets: Butyl rubber, neoprene, or EPDM polymer with polyisobutylene plasticizer.

F. Round Duct Joint O-Ring Seals:

1. Seal shall provide maximum leakage class of 3 cfm/100 sq. ft. at 1-inch wg and shall be rated for 10-inch wg static-pressure class, positive or negative.
2. EPDM O-ring to seal in concave bead in coupling or fitting spigot.
3. Double-lipped, EPDM O-ring seal, mechanically fastened to factory-fabricated couplings and fitting spigots.

2.6 HANGERS AND SUPPORTS

A. Hanger Rods: Galvanized, all-thread rods or galvanized sheet steel.

- B. Strap and Rod Sizes: Comply with SMACNA's "HVAC Duct Construction Standards - Metal and Flexible," Table 4-1, "Rectangular Duct Hangers Minimum Size," and Table 4-2, "Minimum Hanger Sizes for Round Duct."
- C. Duct Attachments: Sheet metal screws, blind rivets, or self-tapping metal screws; compatible with duct materials.
- D. Building Attachments: Refer to Division 20 Section "Mechanical Hangers and Supports".
- E. Refer to Division 20 Section "Mechanical Hangers and Supports" for additional requirements.
- F. Trapeze and Riser Supports:
 - 1. Supports for Galvanized-Steel Ducts: Galvanized-steel shapes and plates.

2.7 DUCT LINER

- A. Fibrous-Glass Duct Liner: Comply with ASTM C 1071, NFPA 90A, or NFPA 90B; and with NAIMA AH124, "Fibrous Glass Duct Liner Standard."
 - 1. Manufacturers: Subject to compliance with requirements, provide products by one of the following:
 - a. CertainTeed Corporation; Insulation Group.
 - b. Johns Manville.
 - c. Knauf Insulation.
 - d. Owens Corning.
 - 2. Maximum Thermal Conductivity:
 - a. Type I, Flexible: 0.27 Btu x in./h x sq. ft. x deg F at 75 deg F mean temperature.
 - 3. Antimicrobial Erosion-Resistant Coating: Apply to the surface of the liner that will form the interior surface of the duct to act as a moisture repellent and erosion-resistant coating. Antimicrobial compound shall be tested for efficacy by an NRTL and registered by the EPA for use in HVAC systems.
 - 4. Liner Adhesive: Comply with NFPA 90A or NFPA 90B and with ASTM C 916.
 - 5. Noise Reduction Coefficient: .70 minimum.
- B. Insulation Pins and Washers:
 - 1. Cupped-Head, Capacitor-Discharge-Weld Pins: Copper- or zinc-coated steel pin, fully annealed for capacitor-discharge welding, length to suit depth of insulation indicated with integral 1-1/2-inch galvanized carbon-steel washer.

2. Insulation-Retaining Washers: Self-locking washers formed from 0.016-inch- thick galvanized steel; with beveled edge sized as required to hold insulation securely in place but not less than 1-1/2 inches in diameter.
- C. Shop Application of Duct Liner: Comply with SMACNA's "HVAC Duct Construction Standards - Metal and Flexible," Figure 2-19, "Flexible Duct Liner Installation."
1. Adhere a single layer of indicated thickness of duct liner with at least 90 percent adhesive coverage at liner contact surface area. Attaining indicated thickness with multiple layers of duct liner is prohibited.
 2. Apply adhesive to transverse edges of liner facing upstream that do not receive metal nosing.
 3. Butt transverse joints without gaps, and coat joint with adhesive.
 4. Fold and compress liner in corners of rectangular ducts or cut and fit to ensure butted-edge overlapping.
 5. Do not apply liner in rectangular ducts with longitudinal joints, except at corners of ducts, unless duct size and dimensions of standard liner make longitudinal joints necessary.
 6. Apply adhesive coating on longitudinal seams in ducts with air velocity of 2500 fpm.
 7. Secure liner with mechanical fasteners 4 inches from corners and at intervals not exceeding 12 inches transversely; at 3 inches from transverse joints and at intervals not exceeding 12 inches longitudinally.
 8. Secure transversely oriented liner edges facing the airstream with metal nosings that have either channel or "Z" profiles or are integrally formed from duct wall. Fabricate edge facings at the following locations:
 - a. Fan discharges.
 - b. Intervals of lined duct preceding unlined duct.
 - c. Upstream edges of transverse joints in ducts where air velocities are higher than 2500 fpm or where indicated.

PART 3 - EXECUTION

3.1 DUCT INSTALLATION

- A. Drawing plans, schematics, and diagrams indicate general location and arrangement of duct system. Indicated duct locations, configurations, and arrangements were used to size ducts and calculate friction loss for air-handling equipment sizing and for other design considerations. Install duct systems as indicated.
- B. Install ducts according to SMACNA's "HVAC Duct Construction Standards - Metal and Flexible" unless otherwise indicated.
- C. Install round ducts in maximum practical lengths.
- D. Install ducts with fewest possible joints.
- E. Install factory-fabricated fittings for changes in direction, size, and shape and for branch connections.

- F. Unless otherwise indicated, install ducts vertically and horizontally, and parallel and perpendicular to building lines.
- G. Install ducts close to walls, overhead construction, columns, and other structural and permanent enclosure elements of building.
- H. Install ducts with a clearance of 1 inch, plus allowance for insulation thickness.
- I. Where ducts pass through non-fire-rated interior partitions and exterior walls or roof and are exposed to view, cover the opening between the partition and duct or duct insulation with sheet metal flanges of same metal thickness as the duct. Overlap openings on four sides by at least 1-1/2 inches.
- J. Protect duct interiors from moisture, construction debris and dust, and other foreign materials. Comply with SMACNA's "Duct Cleanliness for New Construction Guidelines."

3.2 SEAM AND JOINT SEALING

- A. Seal duct seams and joints for duct static-pressure and leakage classes specified in "Performance Requirements" Article, according to SMACNA's "HVAC Duct Construction Standards - Metal and Flexible," Table 1-2, "Standard Duct Sealing Requirements," unless otherwise indicated.
- B. Seal Classes: Comply with SMACNA's "HVAC Duct Construction Standards - Metal and Flexible," Table 1-2, "Standard Duct Sealing Requirements."
 - 1. For static-pressure classes 1- and 1/2-inch wg, comply with SMACNA's "HVAC Duct Construction Standards - Metal and Flexible," Seal Class C.

3.3 HANGER AND SUPPORT INSTALLATION

- A. Comply with SMACNA's "HVAC Duct Construction Standards - Metal and Flexible," Chapter 4, "Hangers and Supports."
- B. Building Attachments: Refer to Division 20 Section "Mechanical Hangers and Supports" for acceptable methods of attachment to building.
- C. Hanger Spacing: Comply with SMACNA's "HVAC Duct Construction Standards - Metal and Flexible," Table 4-1, "Rectangular Duct Hangers Minimum Size," and Table 4-2, "Minimum Hanger Sizes for Round Duct," for maximum hanger spacing; install hangers and supports within 24 inches of each elbow and within 48 inches of each branch intersection.
- D. Hangers Exposed to View: Threaded rod and angle or channel supports.

- E. Support vertical ducts with steel angles or channel secured to the sides of the duct with welds, bolts, sheet metal screws, or blind rivets; support at each floor and at a maximum intervals of 16 feet.
- F. Install upper attachments to structures. Select and size upper attachments with pull-out, tension, and shear capacities appropriate for supported loads and building materials where used.

3.4 CONNECTIONS

- A. Comply with SMACNA's "HVAC Duct Construction Standards - Metal and Flexible" for branch, outlet and inlet, and terminal unit connections.

3.5 PAINTING

- A. Paint interior of metal ducts that are visible through registers and grilles and that do not have duct liner. Apply one coat of flat, black, latex paint over a compatible galvanized-steel primer. Paint materials and application requirements are specified in Division 9 painting Sections.

3.6 FIELD QUALITY CONTROL

- A. Perform tests and inspections.
- B. Leakage Tests:
 - 1. Comply with SMACNA's "HVAC Air Duct Leakage Test Manual."
 - 2. Test the following systems:
 - a. New 3" w.c. pressure class and higher] supply ducts.
 - b. New exhaust systems.
 - 3. Disassemble, reassemble, and seal segments of systems to accommodate leakage testing and for compliance with test requirements.
 - 4. Test for leaks before insulation application.
 - 5. Conduct tests at static pressures equal to maximum design pressure of system or section being tested. If static-pressure classes are not indicated, test entire system at maximum system design pressure. Do not pressurize systems above maximum design operating pressure. Give seven days' advance notice for testing.
- C. Duct system will be considered defective if it does not pass tests and inspections.

3.7 DUCT SCHEDULE

- A. Fabricate ducts with galvanized sheet steel except as follows:

1. Acid Resistant Fume-Handling Ducts (applies to all duct branches, mains, etc. connected to fume hoods and conveying fume hood exhaust): Epoxy coated, interior, galvanized sheet.
- B. Intermediate Reinforcement:
1. Galvanized-Steel Ducts: Galvanized steel.
- C. Elbow Configuration:
1. Rectangular Duct: Comply with SMACNA's "HVAC Duct Construction Standards - Metal and Flexible," Figure 2-2, "Rectangular Elbows."
 - a. Install turning vanes in mitered elbows (exception – fume handling acid resistant ducts do not provide turning vanes).
 - b. Radiused elbows shall be fabricated with a radius of 1.5 times duct diameter.
 2. Round Duct: Comply with SMACNA's "HVAC Duct Construction Standards - Metal and Flexible," Figure 3-3, "Round Duct Elbows."
 - a. Minimum Radius-to-Diameter Ratio and Elbow Segments: Comply with SMACNA's "HVAC Duct Construction Standards - Metal and Flexible," Table 3-1, "Mitered Elbows." Elbows with less than 90-degree change of direction have proportionately fewer segments.
 - 1) 1.5 radius-to-diameter ratio and five segments for 90-degree elbow.
- D. Liner:
1. Rectangular supply air ducts downstream of air terminal units: Fibrous glass, Type I
- E. Branch Configuration:
1. Rectangular Duct: Comply with SMACNA's "HVAC Duct Construction Standards - Metal and Flexible," Figure 2-6, "Branch Connections."
 - a. Rectangular Main to Rectangular Branch: 45-degree entry.
 - b. Rectangular Main to Round Branch: Spin in.
 2. Round: Comply with SMACNA's "HVAC Duct Construction Standards - Metal and Flexible," Figure 3-4, "90 Degree Tees and Laterals," and Figure 3-5, "Conical Tees." Saddle taps are permitted in existing duct.
 - a. Low pressure duct (1" static pressure class): 90-degree tap.
 - b. Medium pressure duct (2" static pressure class): Conical tap.
 - c. High pressure duct (3" static pressure class and greater): 45-degree lateral.

F. Double Wall Ducts:

1. The following round ducts and fittings shall be double wall:
 - a. Supply air ducts exposed in finished spaces.
 - b. Other ducts as shown on the Drawings.

END OF SECTION 233113

SECTION 233300 – DUCT ACCESSORIES

PART 1 - GENERAL

1.1 RELATED DOCUMENTS

- A. Drawings and general provisions of the Contract, including General and Supplementary Conditions and Division 1 Specification Sections, apply to this Section.

1.2 SUMMARY

- A. Section Includes:
 - 1. Manual volume dampers.
 - 2. Turning vanes.
 - 3. Duct-mounted access doors.
 - 4. Duct accessory hardware.

1.3 SUBMITTALS

- A. Product Data: For each type of product indicated.
- B. Operation and Maintenance Data: For air duct accessories to include in operation and maintenance manuals.

1.4 QUALITY ASSURANCE

- A. Comply with NFPA 90A, "Installation of Air Conditioning and Ventilating Systems," and with NFPA 90B, "Installation of Warm Air Heating and Air Conditioning Systems."

PART 2 - PRODUCTS

2.1 MATERIALS

- A. Comply with SMACNA's "HVAC Duct Construction Standards - Metal and Flexible" for acceptable materials, material thicknesses, and duct construction methods unless otherwise indicated. Sheet metal materials shall be free of pitting, seam marks, roller marks, stains, discolorations, and other imperfections.
- B. Galvanized Sheet Steel: Comply with ASTM A 653/A 653M.
 - 1. Galvanized Coating Designation: G90.

2. Exposed-Surface Finish: Mill phosphatized.

C. Reinforcement Shapes and Plates: Galvanized-steel reinforcement where installed on galvanized sheet metal ducts.

D. Tie Rods: Galvanized steel, 1/4-inch minimum diameter for lengths 36 inches or less; 3/8-inch minimum diameter for lengths longer than 36 inches.

2.2 MANUAL VOLUME DAMPERS

A. Standard, Steel, Manual Volume Dampers:

1. Manufacturers: Subject to compliance with requirements, provide products by one of the following:

- a. Air Balance Inc.; a division of Mestek, Inc.
- b. American Warming and Ventilating; a division of Mestek, Inc.
- c. McGill AirFlow LLC.
- d. METALAIRE, Inc.
- e. Nailor Industries Inc.
- f. Ruskin Company.
- g. Cesco.
- h. Greenheck.
- i. Lindab.
- j. Vent Products Company, Inc.

2. Rectangular – Single Blade:

- a. Frames: 22 gauge galvanized steel.
- b. Blades: 22 gauge galvanized steel, 12" maximum height.
- c. Bearings: Molded Synthetic.
- d. Maximum Velocity: 1500 FPM.
- e. Hardware: External hand quadrant with locking nut. 2" stand-off mounting bracket for externally insulated ducts.
- f. Basis of Design: Ruskin MD25.

3. Rectangular Multi-Blade.

- a. Frames: 16 gauge galvanized steel channel.
- b. Blades: 16 gauge galvanized steel, 8" maximum width, opposed blade action.
- c. Bearings: Molded synthetic.
- d. Linkage: Concealed in frame.
- e. Maximum velocity: 1500 FPM.
- f. Hardware: External hand quadrant with locking nut. 2" stand-off mounting bracket for externally insulated ducts.
- g. Basis of Design: Ruskin MD35.

4. Round:

- a. Frames: 20 gauge galvanized steel.
- b. Blades: 20 gauge galvanized steel.
- c. Bearings: Molded synthetic.
- d. Maximum velocity: 1500 FPM.
- e. Hardware: External hand quadrant with locking nut. 2" stand-off mounting bracket for externally insulated ducts.
- f. Basis of Design: Ruskin MDRS25.

2.3 TURNING VANES

- A. Manufacturers: Subject to compliance with requirements, provide products by one of the following:
 1. Ductmate Industries, Inc.
 2. Duro Dyne Inc.
 3. METALAIRE, Inc.
 4. SEMCO Incorporated.
 5. Ward Industries, Inc.; a division of Hart & Cooley, Inc.
- B. Turning Vanes for Metal Ducts: Curved blades of galvanized sheet steel; support with bars perpendicular to blades set; set into vane runners suitable for duct mounting.
- C. General Requirements: Comply with SMACNA's "HVAC Duct Construction Standards - Metal and Flexible"; Figures 2-3, "Vanes and Vane Runners," and 2-4, "Vane Support in Elbows."
- D. Vane Construction: Double wall.

2.4 DUCT-MOUNTED ACCESS DOORS

- A. Manufacturers: Subject to compliance with requirements, provide products by one of the following:
 1. American Warming and Ventilating; a division of Mestek, Inc.
 2. Cesco Products; a division of Mestek, Inc.
 3. Ductmate Industries, Inc.
 4. Flexmaster U.S.A., Inc.
 5. Greenheck Fan Corporation.
 6. McGill AirFlow LLC.
 7. Nailor Industries Inc.
 8. Pottorff; a division of PCI Industries, Inc.
 9. Ventfabrics, Inc.
 10. Ward Industries, Inc.; a division of Hart & Cooley, Inc.
 11. KEES, Inc.
- B. Duct-Mounted Access Doors: Fabricate access panels according to SMACNA's "HVAC Duct Construction Standards - Metal and Flexible"; Figures 2-10, "Duct Access Doors and Panels," and 2-11, "Access Panels - Round Duct."

1. Door:
 - a. Double wall, rectangular.
 - b. Galvanized sheet metal with insulation fill and thickness as indicated for duct pressure class.
 - c. Hinges and Latches: 1-by-1-inch piano hinge and cam latches.
 - d. Fabricate doors airtight and suitable for duct pressure class.
2. Frame: Galvanized sheet steel, with bend-over tabs and foam gaskets.
3. Number of Hinges and Locks:
 - a. Access Doors Less Than 12 Inches Square: No hinges and two sash locks.
 - b. Access Doors up to 18 Inches Square and larger: Continuous hinge and two sash locks.
 - c. Access Doors Larger Than 24 by 48 Inches: Continuous hinge and two compression latches with outside and inside handles.

PART 3 - EXECUTION

3.1 INSTALLATION

- A. Install duct accessories according to applicable details in SMACNA's "HVAC Duct Construction Standards - Metal and Flexible" for metal ducts and in NAIMA AH116, "Fibrous Glass Duct Construction Standards," for fibrous-glass ducts.
- B. Install duct accessories of materials suited to duct materials; use galvanized-steel accessories in galvanized-steel and fibrous-glass ducts, stainless-steel accessories in stainless-steel ducts, and aluminum accessories in aluminum ducts.
- C. Install volume dampers at points on supply, return, and exhaust systems where branches extend from larger ducts. Install duct mounted volume dampers in locations where balancing cfm is indicated on plans.
 1. Install steel volume dampers in steel ducts.
- D. Set dampers to fully open position before testing, adjusting, and balancing.
- E. Install duct access doors on sides of ducts to allow for inspecting, adjusting, and maintaining accessories and equipment at the following locations:
 1. On both sides of duct coils.
 2. Downstream from manual volume dampers, control dampers, and equipment.
 3. Elsewhere as indicated.
- F. Install access doors with swing against duct static pressure.

G. Access Door Sizes:

1. One-Hand or Inspection Access: 8 by 5 inches.
2. Two-Hand Access: 12 by 6 inches.
3. Head and Hand Access: 18 by 10 inches.
4. Head and Shoulders Access: 21 by 14 inches.
5. Body Access: 25 by 14 inches.
6. Body plus Ladder Access: 25 by 17 inches.

- H. Label access doors according to Division 20 Section "Mechanical Identification" to indicate the purpose of access door.

3.2 FIELD QUALITY CONTROL

A. Tests and Inspections:

1. Operate dampers to verify full range of movement.
2. Inspect locations of access doors and verify that purpose of access door can be performed.
3. Inspect turning vanes for proper and secure installation.

END OF SECTION 233300

SECTION 233713 – DIFFUSERS, REGISTERS, AND GRILLES

PART 1 - GENERAL

1.1 RELATED DOCUMENTS

- A. Drawings and general provisions of the Contract, including General and Supplementary Conditions and Division 1 Specification Sections, apply to this Section.

1.2 SUMMARY

- A. Section Includes:

- 1. Radial Flow Diffusers.
- 2. Fixed face grilles.

- B. Related Sections:

- 1. Division 23 Section "Duct Accessories" for and volume-control dampers not integral to diffusers, registers, and grilles.

1.3 SUBMITTALS

- A. Product Data: For each type of product indicated, include the following:

- 1. Data Sheet: Indicate materials of construction, finish, and mounting details; and performance data including throw and drop, static-pressure drop, and noise ratings.
- 2. Diffuser, Register, and Grille Schedule: Indicate drawing designation, room location, quantity, model number, size, and accessories furnished.

1.4 PERFORMANCE AND CONSTRUCTION

- A. Performance data for the products submitted shall meet or exceed those scheduled on the plans for throw distances, pressure drops, and noise criteria.

- B. Construction requirements for products specified shall comply with the models scheduled on the plans.

PART 2 - PRODUCTS

2.1 CEILING DIFFUSERS

A. Radial Flow Diffusers:

1. Manufacturers: Subject to compliance with requirements, provide products by one of the following:

- a. Krueger TAD.
- b. Anemostat.
- c. Nailor Industries Inc.
- d. Price Industries.
- e. Titus.
- f. Tuttle & Bailey.

2. Description: Non-aspirating, radial displacement diffuser.

3. Diffuser:

- a. Material: Aluminum.
- b. Finish: White baked powder coat paint.
- c. Internal blades.
- d. Perforated diffuser screen.
- e. Flow measuring tap.

4. Backpan:

- a. Material: Steel.
- b. Finish: White baked powder coat paint.
- c. Baffle screen.
- d. Inlet duct collar.
- e. Foam gasket seal.

B. Fixed Face Grille:

1. Manufacturers: Subject to compliance with requirements, provide products by one of the following:

- a. Anemostat Products; a Mestek company.
- b. Hart & Cooley Inc.
- c. Krueger.
- d. Nailor Industries Inc.
- e. Price Industries.
- f. Titus.
- g. Tuttle & Bailey.

2. Material: Steel or Aluminum as scheduled on plans.

3. Face Arrangement: Louvered, perforated or eggcrate core as scheduled on plans.

4. Core Construction: Removable for perforated and eggcrate types.

5. Mounting: Provide concealed fasteners and separate mounting frame for installation in sidewalls and inaccessible ceilings. T-bar mounting in T-bar ceilings.
6. Damper Type: Opposed blade dampers where indicated on drawings.

2.2 SOURCE QUALITY CONTROL

- A. Verification of Performance: Rate diffusers, registers, and grilles according to ASHRAE 70, "Method of Testing for Rating the Performance of Air Outlets and Inlets."

PART 3 - EXECUTION

3.1 EXAMINATION

- A. Examine areas where diffusers, registers, and grilles are to be installed for compliance with requirements for installation tolerances and other conditions affecting performance of equipment.
- B. Proceed with installation only after unsatisfactory conditions have been corrected.

3.2 INSTALLATION

- A. Install diffusers, registers, and grilles level and plumb.
- B. Ceiling-Mounted Outlets and Inlets: Drawings indicate general arrangement of ducts, fittings, and accessories. Air outlet and inlet locations have been indicated to achieve design requirements for air volume, noise criteria, airflow pattern, throw, and pressure drop. Make final locations where indicated, as much as practical. For units installed in lay-in ceiling panels, locate units in the center of panel. Where architectural features or other items conflict with installation, notify Architect for a determination of final location.
- C. Install diffusers, registers, and grilles with airtight connections to ducts and to allow service and maintenance of dampers, air extractors, and fire dampers.

3.3 ADJUSTING

- A. After installation, adjust diffusers, registers, and grilles to air patterns indicated, or as directed, before starting air balancing.

END OF SECTION 233713

SECTION 238217 – REHEAT COILS

PART 1 – GENERAL

1.01 SUMMARY:

A. Section Includes:

1. Reheat coils.

B. Related Requirements:

1. SECTION 20 0500 – Common Mechanical Work Results
2. SECTION 20 0503 – Basic Piping Materials and Methods
3. SECTION 20 0700 – Mechanical Insulation
4. SECTION 23 2113 – Hydronic Piping

1.02 DESCRIPTION:

A. Performance Requirements:

1. Sizes, capacities and limitations as shown on the Drawings.
2. Performance shall be based at sea level, unless otherwise noted to be at altitude.

1.03 SUBMITTALS:

A. Product Data:

1. Submit manufacturer's product data in accordance with SECTION 20 0500 – Common Mechanical Work Results.
2. Product data shall include rated capacities.
3. Drawings shall indicate dimensions, required clearances and locations and size of field connections.

1.04 QUALITY ASSURANCE:

A. Certifications:

1. Ratings shall be in accordance with AHRI Standard 410.

1.05 DELIVERY, STORAGE AND HANDLING:

- A. Comply with manufacturer's instructions for rigging, unloading, and transporting equipment.
- B. Protect coils from physical damage. Leave factory shipping covers in place until installation. Protect coils from entry of dirt and debris.

PART 2 – PRODUCTS

2.1 MANUFACTURERS:

- A. Subject to compliance with requirements, the following manufacturers are acceptable:
- B. Water Coils:
 - 1. Trane TT.
 - 2. Aerofin.
 - 3. Heatcraft.

2.2 COILS:

- A. Water Coils:
 - 1. Construction: Copper tubes mechanically expanded into fin collars.
 - 2. Tubes: 5/8" OD x 0.024" wall copper.
 - 3. Fins: 0.0095" aluminum.
 - 4. Maximum fins per foot: 144.
 - 5. Headers: Steel or copper.
 - 6. Connections: Copper or red brass. Same end.
 - 7. Casings: 16 gauge galvanized steel.
 - 8. Maximum working pressure: 225 psig.
 - 9. Maximum temperature: 325 °F.

PART 3 – EXECUTION

3.1 EXAMINATION:

- A. Examine area and conditions where coils will be installed. Do not proceed with work until unsatisfactory conditions have been corrected.

3.2 INSTALLATION:

- A. Install coils where shown on the Drawings in accordance with manufacturer's instructions. Maintain manufacturer's recommended clearances for servicing and maintenance.
- B. Supports:
 - 1. Provide supplemental framing to properly support coils independent of connecting piping and sheet metal.
- C. Piping:
 - 1. Make piping connections and provide valves and accessories as shown on the Drawings.
 - 2. Arrange piping so that valves and accessories are accessible for service and maintenance.
- D. Duct Connections:
 - 1. Transition duct to coils as required.

2. Provide airtight connection between coil and duct.

E. Insulation:

1. Insulate coils as specified in SECTION 200700 – Mechanical Insulation.

END OF SECTION 238217

SECTION 260001 – BASIC ELECTRICAL REQUIREMENTS

PART 1 - GENERAL

1.1 RELATED DOCUMENTS

- A. Drawings and general provisions of the Contract, including General and Supplementary Conditions and Division 1 Specification Sections, apply to this Section.
- B. Related Sections include the following:
 - 1. Division 27 Section “Communications”.

1.2 SUMMARY

- A. This Section includes basic electrical requirements for the project.
- B. This Section applies to all contractors performing work under Division 26, and Division 28 Section “Fire Alarm Systems”.

1.3 MANUFACTURERS

- A. Design Basis Manufacturer: Where listed in each respective Division 26 Section, the “Design Basis Manufacturer” model series number shall serve to indicate the level of quality and minimum requirements for the equipment to be furnished.
- B. Acceptable Manufacturers: Where acceptable manufacturers are listed in each respective Division 26 Section, this shall be interpreted to mean that equipment by the listed manufacturers will be acceptable as equivalent to the “Design Basis Manufacturer” equipment provided that the manufacturer demonstrates full compliance with all of the requirements contained in these specifications.

1.4 DEFINITIONS

- A. Concealed: Indicates item shall be hidden from sight in trenches, chases, furred spaces, shafts, suspended ceilings, encased in construction, underground, under slab, in crawl spaces, etc.
- B. Concealed Space: All furred spaces, pipe chases, spaces above finished ceilings, crawl spaces, and other areas not generally accessible to the occupants.
- C. Exposed: Indicates item shall not be installed “Concealed” (i.e. not hidden from sight) as defined in this Section.
- D. Equipment: Any manufactured item (e.g. luminaire, panelboard, switchgear, wiring device, etc.).
- E. Electrical Space: Any space designated primarily for the installation of electrical equipment.

- F. Finished Space: Any space designated for the general or specific used of the occupants.
- G. NFPA 70 (National Electrical Code): All references to NFPA 70 on drawings or specifications shall refer to the currently adopted NFPA 70 code with all amendments in the state having jurisdiction.
- H. Provide: Furnish and install the specific item, equipment, and/or system.
- I. Furnish: Furnish and install the specific item, equipment, and/or system.
- J. Install: Furnish and install the specific item, equipment, and/or system unless specifically noted to be furnished by others.
- K. Rough-In: Suitable conduits terminated at each end in a suitable box.
- L. Work: Labor and installation including materials, equipment, systems, etc. required for completion of any or all portions of the project.
- M. Underground: That portion of work that is located below grade or under any building floor slab on compacted fill whether concrete encased or not.

1.5 ABBREVIATIONS

- A. Refer to Division 27 Section "Basic Telecommunications Requirements" for additional abbreviations.
- B. Refer to Division 27 Section "Communications" for additional abbreviations.
- C. The following abbreviations where used on the electrical drawings shall be defined as follows:
 - 1. A or AMP: Amperes or Ampacity.
 - 2. AFF: Above Finished Floor.
 - 3. AV: Audio-Visual.
 - 4. C: Conduit.
 - 5. CB: Circuit Breaker.
 - 6. CCTV: Closed Circuit Television System.
 - 7. CKT: Circuit.
 - 8. COMB: Combination.
 - 9. CU: Copper.
 - 10. E-G: Engine-Generator.
 - 11. EC: Electrical Contractor.
 - 12. EM: On Emergency Circuit.
 - 13. EMT: Electrical Metallic Tubing.
 - 14. FA: Fire Alarm.
 - 15. FDS: Fusible Disconnect Switch.
 - 16. FMC: Flexible Metal Conduit.
 - 17. GC: General Contractor.
 - 18. G: Green Grounding Conductor.
 - 19. GND or GRND: Ground.
 - 20. HP: Horsepower.
 - 21. IMC: Intermediate Metal Conduit.
 - 22. JB: Junction Box.

- 23. kV: Kilovolts.
- 24. kVA: Kilovolt-Amperes
- 25. kW: Kilowatts.
- 26. LFMC: Liquidtight Flexible Metal Conduit.
- 27. MATV: Master Antenna Television System.
- 28. MC: Mechanical Contractor.
- 29. MCC: Motor Control Center.
- 30. MH: Manhole.
- 31. MTR: Motor.
- 32. NEC: National Electrical Code.
- 33. NEMA: National Electrical Manufacturers Association.
- 34. NIC: Not In This Contract.
- 35. NL: Night Light.
- 36. PH or Φ : Phase.
- 37. PBS: Pushbutton Station.
- 38. PNL: Panel.
- 39. PVC: Polyvinylchloride.
- 40. RM: Room.
- 41. RMC: Rigid Metal Conduit.
- 42. RNC: Rigid Nonmetallic Conduit.
- 43. STD: Standard.
- 44. STR: Motor Controller.
- 45. SS: Stainless Steel.
- 46. TV: Television.
- 47. TYP: Typical.
- 48. UG: Underground.
- 49. UL: Underwriters' Laboratories, Inc.
- 50. UNO: Unless Noted Otherwise.
- 51. V: Volts.
- 52. W: Watts.
- 53. WP: Weatherproof.

1.6 GENERAL

- A. The electrical drawings are diagrammatic only and are intended to convey the scope of work and indicate general arrangement of equipment, conduits, devices, fixtures, etc. The electrical drawings shall not be scaled for purposes of equipment installation. All measurements shall be verified as required to install all equipment in a neat and workmanlike manner.
- B. The physical size, arrangement and capacities of equipment indicated on the drawings corresponds to the particular manufacturer named on the drawings or one of the manufacturers listed in the specification. If this contractor elects to use equipment by another manufacturer named in the specifications, it shall be this contractor's responsibility to adjust his work and to compensate the other contractors for additional work that may be required by them to accommodate or serve this contractor's equipment.
- C. The Engineer reserves the right to make changes in the locations of receptacles, apparatus and equipment up to the time of rough-in or setting without additional cost to the project. The contractor shall, without extra charge, make reasonable modifications to the electrical layout for the following:
 - 1. As needed to prevent conflict with the work of other trades or for proper execution of the work.

2. As directed by the Engineer in writing, prior to component installation, for minor revisions to electrical installation.
- D. This contractor shall cooperate and coordinate work with other trades so as to not delay the completion date of the project. This contractor will study and be familiar with the work of other trades as required for proper coordination.
- E. Certain electrical work is indicated on the drawings and specifications of other trades and may not be repeated on the electrical drawings and specifications. This contractor shall examine the documents of other trades and include all electrical work in the bid as required for a complete electrical system(s), unless specifically noted as provided by others.
- F. Complete rough-in requirements of all equipment to be wired or connected under this project are not shown on the drawings. This contractor shall verify all requirements with the contractor furnishing the equipment or with the owner where the equipment is owner furnished, for the exact installation requirements.
- G. This contractor shall examine the architectural drawings and verify sufficient wall thickness for proper recessing depth for all flush mounted equipment. All instances of inadequate depth shall be brought to the attention of the Engineer before the bid date or provided for by this contractor.

1.7 CODES, FEES, AND PERMITS

- A. Codes: All work shall be installed in strict accordance with the currently adopted NFPA 70, National Electrical Code with all amendments. The contractor shall provide a copy at the job site at all times.
- B. Codes and Standards: All work shall be installed in accordance with codes as currently adopted and in accordance with standards as referenced elsewhere in these specifications. Applicable codes, standards and publications by professional agencies shall include but not be limited to the following:
 1. ANSI – American National Standards Institute, Inc.
 2. ASTM – American Society for Testing and Materials.
 3. IEEE – Institute of Electrical and Electronics Engineers.
 4. IESNA – Illuminating Engineering Society of North America.
 5. IPCEA – Insulated Power Cable Engineers Association.
 6. JIC – Joint Industrial Council.
 7. NBS – National Bureau of Standards.
 8. NEC – National Electrical Code.
 9. NECA – National Electrical Contractors Association.
 10. NESC – National Electrical Safety Code.
 11. NEMA – National Electrical Manufacturers Association.
 12. NFPA – National Fire Protection Association.
 13. OSHA – Occupational Safety and Health Act.
 14. UL – Underwriters' Laboratories, Inc.
- C. Permits: The contractor shall obtain and pay for all necessary permits required by authorities having jurisdiction.
- D. U.L. Label: All materials provided under this contract shall bear the Underwriters Laboratories label where available to the specific item of equipment.

- E. OSHA: The contractor shall adhere to all applicable requirements of the Occupational Safety and Health Act of 1970 and latest editions.

1.8 SUBMITTALS

- A. Provide all submittals as indicated in each specific specification section and as required by Submittal Section in Division One. Submittals required for performance of the work include the following:
 - 1. Shop Drawings.
 - 2. Product Data.
 - 3. Samples.
 - 4. Other submittals as required by respective specification sections.
- B. Contractor's Responsibility: Submittals are the sole responsibility of the Contractor. The Contractor is solely responsible for providing submittals demonstrating full compliance with the Contract Documents including completeness, accuracy, and coordination.
- C. All submittals shall comply with the following:
 - 1. Organized by specification sections and submitted complete for all manufactured items within the same specification section; partial submittals or submittals from multiple specification sections combined into a common submittal will not be permitted and will be returned un-reviewed or rejected.
 - 2. Be submitted with the following information included:
 - a. Date submitted.
 - b. Project title and project number.
 - c. Name, address, and telephone number of the Contractor.
 - d. Name, address, and telephone number of the Architect.
 - e. Name, address, and telephone number of the Engineer.
 - f. Name, address, and telephone number of the supplier, manufacturer and/or subcontractor.
 - g. Number and title of the appropriate specification section.
 - h. Notification of deviations from the Contract Documents.
 - i. Contractor's stamp signed and dated by the contractor as required elsewhere in these specifications.
 - 3. Be submitted with each item of equipment, component, etc., for review clearly marked and indicated where included with product data sheets.
 - 4. Collated; where multiple cut sheets are submitted for the same components and multiple items are included in that section, the submittals shall be collated into the required number of sets of shop drawings as required in other sections of this specification.
 - 5. Include wiring diagrams, riser diagrams, floor plans, etc. showing the quantity and types of cables and respective conduit sizes required for special systems such as Fire Alarm, Sound Systems, Access Control, etc. as elsewhere required in these specifications. Note: drawings will be returned for completion if the locations and routings of all devices, conduits, and cables are not shown. Delays in the construction schedules due to incomplete drawings shall be the responsibility of this contractor.
 - 6. Be drawn by competent draftspersons.
 - 7. Be drawn in accordance with applicable Owner drawing standards when required under Divisions 0 or 1.

D. Engineer's Review:

1. The Engineer's review of submittals is for determining general compliance with the Contract Documents and is performed as a courtesy to the Contractor and as required by contractual obligation to the owner.
2. Corrections and comments made by the Engineer during review of submittals may not be all inclusive and do not relieve the contractor from full compliance with the Contract Documents. The Engineer reserves the right to re-review submittal information at any time and for any reason and to provide additional or supplemental comments at any time.
3. The contractor is solely responsible for determining all quantities and dimensions; selecting fabrication processes and techniques of construction; coordination of his work with the work of other trades, the owner, and existing conditions; performing all work in a safe and satisfactory manner.

1.9 PRODUCT SAMPLES

- A. The Engineer reserves the right to request an engineering sample product of each and every item of equipment for inspection. Samples submitted shall be in full compliance with the specifications including but not limited to construction, design, visual appearance, and performance. The manufacturer shall have previously built the item and it shall be a production item. The sample shall remain on file as comparison with the materials furnished on the project. Materials not equal to the approved sample will be rejected.

1.10 COORDINATION

- A. Coordinate arrangement, mounting, and support of electrical equipment:
1. To allow maximum possible headroom unless specific mounting heights that reduce headroom are indicated.
 2. To provide for ease of disconnecting the equipment with minimum interference to other installations.
 3. To allow right of way for piping and conduit installed at required slope.
 4. So connecting pathways, cables, wireways, cable trays and enclosed buss assemblies, will be clear of obstructions and of the working and access space of other equipment.
- B. Coordinate installation of required supporting devices and set sleeves in cast-in-place concrete, masonry walls, and other structural components as they are constructed.
- C. Coordinate location of access panels and doors for electrical items that are behind finished surfaces or otherwise concealed. Access doors and panels are specified in Division 8 Section "Access Doors and Frames".
- D. Coordinate sleeve selection and application of firestopping specified in Division 7 Section "Firestopping".

1.11 VERIFICATION

- A. This contractor shall visit the proposed project site and shall verify all existing conditions relative to the project requirements.

- B. Work shown on the drawings as "existing" is assumed to be in place and suitable for modifications and additions as indicated on the drawings. This contractor shall field verify these items prior to bid and shall make all necessary provisions required for proper installation as required by the drawings and specifications. This contractor shall submit any questions requiring clarification in writing to the Engineer not less than ten days prior to the bid date.
- C. This contractor shall verify available recessing depths for luminaires (light fixtures) against luminaire catalog reference material prior to furnishing submittals for review to the Engineer.
- D. This contractor shall verify all necessary vertical and horizontal clearances for the installation of electrical equipment and shall share this information with all associated parties as necessary for proper coordination.

1.12 ELECTRICAL POWER OUTAGES AND CUTOVERS

- A. All necessary power outages for installation of new electrical distribution equipment, modifications to existing electrical distribution equipment, installation or modification of feeder or branch circuits, termination of circuits, and cutovers shall be at a time scheduled with the Owner and approved by the Owner.
- B. All necessary power outages shall be of the shortest possible duration.
- C. The Owner will determine the extent of shutdown of the electrical system required to comply with the Owner's safety standards. This shutdown may include upstream power distribution equipment and feeders including but not limited to the building main primary electrical service, main service switchboards, and sub-distribution switchboards. The Contractor shall coordinate the extent of the shutdown with the Owner's Representatives prior to performing any work requiring shutdowns. The Contractor shall initiate coordination with the Owner's Representatives through the Purdue Project Manager as soon as the Contract is awarded and indicate all proposed outages on the Project Schedule.
- D. The contractor is advised that necessary shutdowns may occur at times outside of normal working or operating schedule. The Contractor shall include costs in his bid any costs for overtime work or work performed outside of normal working or operating hours.

1.13 MATERIALS AND WORKMANSHIP

- A. All materials to be furnished for this project shall be new and of the class and quantity as shown, noted and/or scheduled on the drawings and/or specified in these specifications.
- B. All work and workmanship for this project shall be first quality as approved by the Owner's Representative, or Engineer. NECA 1-2006 "Good Workmanship in Electrical Construction" shall be used as a minimum requirement and shall be improved upon as outlined on the drawings and specifications.

1.14 GUARANTEE

- A. This Contractor shall guarantee all electrical work to be free from defect in material and/or installation for a period of one (1) year from the date of final acceptance. This guarantee shall

not deprive the owner of other rights or other extended guarantees required in other sections of these specifications.

- B. The contractor shall agree to correct, repair and/or replace any deficiencies of any part of the installation under the direction of the Engineer or Owner's Representative for the duration of the guarantee period.

1.15 MOUNTING HEIGHTS

- A. The contractor shall verify all mounting heights with the Engineer or Owner's Representative where not noted or where in conflict prior to rough-in.
- B. Mounting heights shall be as indicated in the following schedule except where specifically noted on the drawings:

Equipment Mounting Height Schedule		
DEVICE	REFERENCE	MOUNTING HEIGHT
Switches	Floor to Top	48"
Dimmer Switches	Floor to Top	48"
Surface Raceway	Floor to Bottom	48"
Wall Speaker	Ceiling to Top	12"
Microphone Input	Floor to Bottom	18"
Power Receptacles	Floor to Bottom	18"
Telecommunications Outlet	Floor to Bottom	18"
Telecommunications Outlet (Wall Telephone)	Floor to Top	48"
Fire Alarm Notification Appliance	Floor to Bottom or	80"
	Ceiling to Top (Whichever is lower)	6"
Fire Alarm Manual Pull Station	Floor to Top	48"
Clock	Ceiling to Top	12"
Control Station	Floor to Top	48"
Relay Panel	Floor to Top	72"
Panelboard	Floor to Top	72"
Motor Starter	Floor to Top	72"
Enclosed Switch	Floor to Top	72"
<u>Notes:</u>		
1. All references are from finished floor or ceiling to the outlet box.		

PART 2 - PRODUCTS

2.1 NOT APPLICABLE

PART 3 - EXECUTION

3.1 NOT APPLICABLE

END OF SECTION 260001

SECTION 260002 - COMMON WORK RESULTS FOR ELECTRICAL

PART 1 - GENERAL

1.1 RELATED DOCUMENTS

- A. Drawings and general provisions of the Contract, including General and Supplementary Conditions and Division 1 Specification Sections, apply to this Section.

1.2 SUMMARY

- A. Section Includes:
 - 1. Branch circuit requirements.
 - 2. Wiring Methods.
 - 3. Coordination.
 - 4. Concrete work.
 - 5. Grout.
 - 6. Installation of work.
 - 7. Housekeeping pads for equipment.
 - 8. Alterations and additions to existing work.
 - 9. Cutting and patching.
 - 10. Painting.
 - 11. Testing.

1.3 SUBMITTALS

- A. Product Data: For all manufactured items.

1.4 BRANCH CIRCUIT REQUIREMENTS

- A. Provide a suitable branch circuit for each and every luminaire (light fixture), receptacle, utilization equipment, etc. inside or outside of the building whether or not specifically noted on the electrical drawings and specifications, including the drawings and specifications of other trades.
- B. Provide a full size neutral for each 120V branch circuit.
- C. Permanently and effectively identify and tape together each neutral conductor with its respective phase conductor in each junction box, outlet box and panelboard where two or more neutrals are installed within the same conduit. Provide markers on the neutral wire numbered the same as the respective branch circuit conductor. See Division 26 Section Electrical Identification for conductor jacket color requirements.
- D. Provide an insulated grounding conductor in each branch circuit conduit and each feeder conduit.

- E. Provide separate conduit system for each different power system where both 208Y/120V 3Ph 4W and 480Y/277V 3Ph 4W systems are installed. This shall apply to all locations including standby and emergency systems wiring.

1.5 WIRING METHODS

- A. Branch Circuits: Wiring for all 208Y/120V 3Ph 4W and 480Y/277V 3Ph branch circuits shall be installed in conduits in accordance with Division 26 Section "Raceways and Fittings".
- B. Feeder Circuits: Wiring for all 208Y/120V 3Ph 4W and 480Y/277V 3Ph feeder circuits shall be installed in conduits in accordance with Division 26 Section "Raceways and Fittings".
- C. Low Voltage Systems: Wiring for all low voltage communications and signaling systems shall be installed in conduits in accordance with Division 26 Section "Raceways and Fittings". This requirement shall apply to the following systems:
 - 1. Fire Alarm System.
 - 2. Access Control systems.
 - 3. Security and Intrusion Detection Systems.
 - 4. Lighting Control Networked Systems.
 - 5. Other Systems specified elsewhere in these specifications.
- D. Telecommunications Systems: Wiring for all telecommunications circuits and systems (voice, data, etc.) shall be installed in accordance with Division 27 Section "Telecommunications Pathways".

1.6 COORDINATION

- A. Coordinate arrangement, mounting, and support of electrical equipment:
 - 1. To allow maximum possible headroom unless specific mounting heights that reduce headroom are indicated.
 - 2. To provide for ease of disconnecting the equipment with minimum interference to other installations.
 - 3. To allow right of way for piping and conduit installed at required slope.
 - 4. So connecting raceways, cables, wireways, cable trays, and enclosed bus assemblies will be clear of obstructions and of the working and access space of other equipment.
- B. Coordinate, check, and verify rough-in heights and locations of all equipment, devices, receptacles, etc. with the drawings, existing conditions, and the work of other trades.
- C. Coordinate installation of required supporting devices and set sleeves in cast-in-place concrete, masonry walls, and other structural components as they are constructed.
- D. Coordinate location of access panels and doors for electrical items that are behind finished surfaces or otherwise concealed. Access doors and panels are specified in Division 8 Section "Access Doors and Frames."
- E. Coordinate sleeve selection and application with selection and application of firestopping specified in Division 7 Section "Firestopping."

PART 2 - PRODUCTS

2.1 GROUT

- A. Nonmetallic, Shrinkage-Resistant Grout: ASTM C 1107, factory-packaged, nonmetallic aggregate grout, noncorrosive, non-staining, mixed with water to consistency suitable for application and a 30-minute working time.

PART 3 - EXECUTION

3.1 INSTALLATION OF WORK

- A. Areas without suspended ceilings:
 - 1. Support conduits from the structure and install exposed as high as possible to avoid future conflicts when new ceilings are installed or when additional work is installed. Route all conduits parallel and perpendicular with the structure.
 - 2. Install conduits concealed in new and existing walls except where specifically shown and noted as exposed on the drawings.
- B. Areas with suspended ceilings:
 - 1. Install conduits concealed above suspended ceilings.
 - 2. Install conduits concealed in new and existing walls except where specifically shown and noted as exposed on the drawings.

3.2 ALTERATIONS AND ADDITIONS TO EXISTING WORK

- A. Provide all necessary additions and alterations to existing work as required to provide and maintain a complete and proper electrical installation.
- B. Field verify on site all items requiring alterations and include all work necessary in bid.
- C. Relocate existing electrical work as shown on the drawings or as required for the installation of new work or as required for the work of other trades. This shall include but not be limited to the following:
 - 1. Relocate existing luminaires (light fixtures), enclosed busways, conduits, pull boxes, etc. as required to permit the installation of new equipment.
 - 2. Provide new conduits and circuitry as required to maintain temporary and permanent use of existing electrical facilities to remain.
 - 3. Disconnect and reconnect existing circuits as required for continued operation of electrical facilities to remain.
 - 4. Provision for the relocation of existing piping, ductwork, etc. as required for the installation of new electrical work where not shown or specified to be provided for by others.
- D. Maintain access and reconnect as required all existing work to remain.

3.3 CUTTING AND PATCHING

- A. Provide all cutting and patching of existing construction except where specified to be provided by others elsewhere in these specifications. Verify exact locations and materials before performing work. The cutting of structural members and bearing walls is prohibited except where specifically shown and noted on the drawings and/or where specifically permitted by the Architect and Structural Engineer.
- B. Cutting:
 - 1. Cut all masonry walls and concrete floors to accommodate new conduits and electrical work by means of core drilling.
 - 2. Provide protection for building occupants and office equipment against dust and damage during cutting operations in all occupied areas.
- C. Patching:
 - 1. Patch all anchor holes where existing equipment and conduits are removed with plaster, vinyl spackle, mortar, or SPEEDCRETE as required by existing construction.
 - 2. Patch all holes in terrazzo floors with SPEEDCRETE or equal material. The top 1" of the hole shall be patched with terrazzo to match existing construction.
 - 3. Patch all holes in walls where conduits have been removed with proper plaster mixes, vinyl spackle, and gypsum board as required by existing construction.
 - 4. Patch all holes in fire rated construction by means specified elsewhere in these specifications.

3.4 PAINTING

- A. Provide painting where required for rustproofing only. Paint cut ends of galvanized channel or angle supports utilizing spray aluminum or similar after suitable cleaning.

3.5 LOAD BALANCING

- A. Upon completion of work, disconnect and reconnect branch lighting circuits at panelboards to obtain as near load balance on circuits as possible. Demonstrate all results to the Owner's Representative and/or Engineer with digital ammeter.
- B. Provide written record of load balance for each panelboard with the closeout documents.

3.6 TESTING

- A. Testing shall be performed in accordance with the provisions of this Section and in accordance with specific provisions contained in each respective Section in these Specifications.
- B. All testing shall be performed in the presence of the Owner's Representative and/or Engineer. Notify all necessary parties in writing a minimum of thirty (30) days in advance of each test.
- C. All testing results shall be recorded in writing and submitted with the closeout documents.
- D. Provide all meters, apparatus, and equipment necessary to perform all testing.

- E. Provide only qualified technicians trained for each system to be tested. Provide factory certification for specialty systems, where applicable and as further outlined in these specifications, documenting technician's credentials and expertise in the system being tested and/or demonstrated.
- F. Replace all work determined during testing to be non-compliant with the requirements of the Contract Documents.
- G. Wiring Installation:
 - 1. Test all wiring after wires, cables, and bus ducts are in place and before being connected to equipment.
 - 2. Test the wiring installation for short circuits, "grounds" and grounded neutrals by means of an approved type of constant potential "megger".
 - 3. Provide a voltage test on the last outlet of each circuit. Repair or replace any high resistance splice resulting in excessive drop in potential.
- H. Motors:
 - 1. Test each and every motor.
 - 2. Provide written record of line current and voltage for each motor under maximum operating conditions. Submit results with closeout documents.
 - 3. Complete the "Motor Test Data Table" attached in this Section and submit with the closeout documents. Upon request, the Engineer will make a blank copy of this table available to the contractor in Excel format for his use.

END OF SECTION 260002

MOTOR TEST DATA TABLE

ROOM NUMBER	MOTOR NUMBER (1)	HP	PHASE	VOLTS	NAME PLATE AMPS	LOCATION OF STARTER & DISC. (2)	FUSE					OVERLOADS					REMARKS	
							TYPE	SIZE	MFGR.	QUANT.	SIZE	AMPS	VOLTS					

06/28/2024

(1) = NUMBER OF FAN, PUMP, ETC.
 (2) = MCC - PH (PENTHOUSE), ETC.

SECTION 260003 – TEMPORARY LIGHT AND POWER

PART 1 - GENERAL

1.1 WORK REQUIRED

- A. The work required under this section consists of providing temporary wiring for the project per NFPA 70, National Electrical Code, Article 590, as specified herein and as further outlined in Division 1 Section “Temporary Requirements and Facilities”.

1.2 RELATED WORK SPECIFIED ELSEWHERE

- A. Division 1 Section “Temporary Requirements and Facilities”.

1.3 GENERAL

- A. Requirements of the Occupational Safety and Health Act of 1970 shall increase but shall not decrease the provisions for temporary lighting and power as outlined herein.
 - 1. The contractor is directed to pay special attention to OSHA Sections pertaining to illumination, lamps, guards, tools, and related items.
- B. Ground fault protection shall be provided where required by National Electrical Code.
 - 1. Ground fault protection equipment shall be provided per National Electrical Code, Article 590.6.
 - 2. The “Assured Equipment Grounding conductor Program” (NEC 590.6(B)(2)) will not be acceptable for this project.
 - 3. Receptacles that are part of the permanent wiring for the building may be used for construction purposes provided that they are used in conjunction with portable Ground Fault Circuit Interrupters.
 - 4. Note: All portable Ground Fault Circuit Interrupters shall be provided by respective trade requiring the same.
- C. Service: Service shall be from the owner’s existing system.
- D. Panelboards: Provide panelboards as follows:
 - 1. Provide one 100A branch circuit panel for each floor under 20,000 gross square feet.
 - 2. In addition to item 1 above, provide an additional 100A branch circuit panel for each additional 20,000 gross square feet or fraction thereof on each floor. Small areas such as attics, penthouses subwalks, and tunnels shall not require a separate panel.
 - 3. Protect each lighting and receptacle branch circuit by a 20A maximum overcurrent protection device.
- E. Temporary Lighting for General Illumination:

1. Furnish, install and maintain temporary 120 volt lines the full length of all corridor and passage spaces complete with one 200 watt lampholder at 20 foot intervals. A maximum of one stringer will be allowed per floor.
2. Provide one 200 watt lampholder centrally located in each space for spaces of less than 200 gross square feet.
3. Provide one 200 watt lampholder per 200 gross square feet of space for spaces larger than 200 square feet. Lampholder shall be distributed on equal intervals throughout the space.
4. All lamp sizes shall be suitable for proper illumination levels.
5. The respective trade requiring additional illumination in any space for finishing operations such as painting, millwork, concrete finishing, etc. shall furnish all necessary lampholders, lamps, and wiring as required for operation extended from the temporary system.
6. Provide all lamps for temporary lighting for this project, including replacement lamps. Spare lamp storage and security shall be the responsibility of the Contractor.
7. Provide switch for lighting at the contractor's entrance to control lights necessary for entry to the building and to the electrical panel where all other lights are controlled.

F. Receptacles:

1. Furnish, install and maintain temporary 120 volt lines the full length of all corridor and passage spaces, complete with grounding type duplex receptacles at 40 foot intervals for use by all contractors.
2. Receptacle circuits shall be sized to provide for simultaneous operation of four 1/2hp small tool motors in every location of the building.
3. Small tools will be plugged into corridor circuits by the respective users.
4. The respective trade requiring any additional power in any space for other tools and equipment shall furnish all necessary outlets, switches, circuitry, and wiring as required extended from the temporary system.
5. Receptacles shall not be installed on branch circuits that supply temporary lighting.
6. Receptacles shall not be connected to the same ungrounded conductor of multiwire circuits that supply temporary lighting.

PART 2 - PRODUCTS

2.1 GROUND FAULT PROTECTION

A. Portable Ground Fault Circuit Interrupters:

1. Hubbell GFP315, GFP6C15, GFP115A, GFP201, GFP3815.

B. Factory Assembled or Job Fabricated Strings of lighting outlets with lamp protectors and grounded metal parts:

1. Equal to equipment manufactured by McGill, Woodhead, or Hubbell.

PART 3 - EXECUTION

3.1 INSTALLATION

- A. Furnish, install and maintain a temporary electric power and lighting wiring system for this project.
- B. All temporary wiring shall be done in accordance with the requirements of the local utility company as required.
- C. All temporary wiring shall be removed without cost to the owner upon completion of the project.

3.2 POWER OUTAGES

- A. All necessary power outages shall be at a time approved by the Owner and shall be of the shortest possible duration.
- B. The Electrical Contractor shall include in his bid any overtime work required for cutovers in order to maintain the Owner's normal operating schedule.
- C. Verify all details with the Owner's Representative who will assist in determining the Owner's requirements.

3.3 ENERGY COSTS

- A. All costs for consumed energy during construction will be provided by the Owner.

END OF SECTION 260003

SECTION 260004 - FIRESTOPPING

PART 1 - GENERAL

1.1 WORK REQUIRED

- A. The work required under this section consists of providing through-penetration fire stops for all penetrations of fire rated construction for this project.
- B. All work shall be installed in compliance with relevant sections of the Indiana Building Code.
- C. All fire stop materials and method shall be U.L. listed.
- D. Applicator shall have two years experience in installing U.L. classified firestopping and be approved for installation of firestopping materials by firestopping manufacturer.

1.2 RELATED WORK SPECIFIED ELSEWHERE

- A. Division 26 Section "Hangers and Supports for Electrical Systems".
- B. Division 26 Section "Raceways and Fittings".
- C. Division 27 Section "Pathways".
- D. Division 27 Section "Copper Horizontal Cabling".

1.3 SUBMITTALS

- A. Submit information on each and every through-penetration fire stop proposed for the project for approval.
- B. Submit drawings of U.L. listed installation details and procedures for each and every condition. Each drawing shall be specifically marked for its intended condition.
- C. Submit all information, drawings, material safety data sheets, etc., as required in Division 7 Section "Firestopping".

PART 2 - PRODUCTS

2.1 MANUFACTURER AND PRODUCT

- A. See Division 7 Section "Firestopping" for all fire stop products.

PART 3 - EXECUTION

3.1 APPLICATION

- A. See Division 7 Section "Firestopping" for execution of firestopping.

END OF SECTION 260004

SECTION 260005 – MISCELLANEOUS WIRING METHODS AND SPECIAL REQUIREMENTS

PART 1 - GENERAL

1.1 RELATED DOCUMENTS

- A. Drawings and general provisions of the Contract, including General and Supplementary Conditions and Division 1 Specification Sections, apply to this Section.

1.2 SUMMARY

- A. This Section includes specific wiring methods, procedures and special requirements for systems not elsewhere outlined in these specifications or shown on the drawings. This Section includes wiring methods and requirements for:
 - 1. Labs.
 - 2. Miscellaneous requirements.

1.3 SUBMITTALS

- A. Provide submittals as required by respective Section of these specifications for the product to be provided.

PART 2 - PRODUCTS

2.1 NOT APPLICABLE

PART 3 - EXECUTION

3.1 LABS

- A. General:
 - 1. Provide a complete electrical wiring installation for all equipment and workstation locations indicated on Drawings.
 - 2. Install all items of an electrical nature that are to be furnished by others. Provide proper branch circuit installation for all such items.
 - 3. Coordinate grommetted openings in furniture and related boxes, finishing plates, and devices will be furnished by the respective supplier of furniture.
- B. Specific Laboratory Requirements:
 - 1. Wiring Methods: Install all conductors in new walls and above ceilings in conduit.
 - 2. Surface Raceways:

- a. Provide all surface raceways in Labs as shown on the drawings. Provide lengths of surface raceways as indicated on the electrical drawings.
- b. Provide concealed rough-in connection to rear of raceway for all surface raceways located on new walls. The opening in the rear of the surface raceway shall match the box opening.
3. Special Receptacles: Receptacles other than standard 120 volt duplex type to be furnished in laboratory spaces shall:
 - a. Be furnished complete with a grounding pole.
 - b. Be coordinated with the owner or owner's item of equipment to match the respective plug for the specific item of equipment for which it is intended.

3.2 MISCELLANEOUS REQUIREMENTS

- A. Mechanical Rooms: Coordinate the locations for all light fixtures to be installed in mechanical rooms with the work of other trades. Pay particular attention to the installation of mechanical ductwork, piping and equipment and adjust the locations of luminaires accordingly.
- B. Sealing Air Barriers: Provide flexible, adhesive, non-cracking type sealing material around electrical work passing through partitions or membranes that act as air flow barriers. The sealing material shall be installed to provide an airtight joint.
- C. Outlet Box Rough-in: Mount each wiring device in a separate box with closed back. Stagger boxes horizontally with offset conduit stubs between boxes as required. Back-to back or through-wall outlet box installations will not be permitted. This requirement is not intended to prohibit installation of multi-ganged devices.
- D. Building Expansion:
 1. Avoid routing conduits through building expansion joints wherever possible.
 2. Provide proper expansion type fitting as outlined elsewhere in these specifications where conduits, busway, etc. are routed to cross building expansion joints.

END OF SECTION 260005

SECTION 260006 – ELECTRICAL DEMOLITION

PART 1 - GENERAL

1.1 RELATED DOCUMENTS

- A. Drawings and general provisions of the Contract, including General and Supplementary Conditions and Division 1 Specification Sections, apply to this Section.
- B. Related sections include the following:
 - 1. Division 2 Section "Selective Demolition."
 - 2. Division 9 Section "Painting."

1.2 SUMMARY

- A. This Section includes the following:
 - 1. Electrical demolition.
 - 2. Cutting and patching for electrical construction.

1.3 QUALITY ASSURANCE

- A. Electrical Components, Devices, and Accessories: Listed and labeled as defined in NFPA 70, Article 100, by a testing agency acceptable to authorities having jurisdiction, and marked for intended use.
- B. Comply with NFPA 70.

1.4 COORDINATION

- A. Sequence, coordinate, and integrate demolition of electrical materials and equipment for efficient flow of the Work. Coordinate electrical disconnection of equipment to be removed by the other trades.

PART 2 - PRODUCTS

2.1 NOT APPLICABLE.

PART 3 - EXECUTION

3.1 EXAMINATION

- A. Drawings are based on the existing record documents and general field observation. Report discrepancies to Architect before disturbing existing installation.
 - 1. Verify field equipment locations and existing circuiting arrangements are as shown on Drawings.
 - 2. Verify that abandoned wiring and equipment serve only abandoned facilities.
- B. Contractor shall visit the site to familiarize himself with the existing conditions. It shall be the contractor's responsibility to review the existing conditions as they relate to the scope of work as defined on the construction documents. Contractor shall review locations of all existing equipment including switchboards, transformers, panelboards, lighting fixtures, outlets, and all other electrical devices, components, etc. in the existing facility. At the beginning of demolition, the contractor accepts the existing conditions, and has included all necessary modifications, removal, demolition, and relocation of the existing components for the execution of the scope of work.

3.2 PREPARATION

- A. Disconnect electrical systems in walls, floors, and ceilings scheduled for removal.
- B. Provide temporary wiring and connections to maintain existing systems in service during construction. When work must be performed on energized equipment or circuits; use personnel experienced in such operations.
- C. Existing Systems, to be modified or remain: These drawings and specifications call for the installation of new systems to be installed adjacent the to existing systems or modification to the existing system. Maintain the existing systems in service. The following existing systems beyond the indicated scope of work shall remain in service:
 - 1. Data/Voice Systems.
 - 2. Fire Alarm System.

3.3 DEMOLITION

- A. Scope of Work:
 - 1. Coordinate scope of work with Division 2 Section "Selective Demolition."
 - 2. Remove all demolished material from Project site.
 - 3. Demolish and extend existing electrical work under provisions of this Section.
 - 4. Remove, relocate, and extend existing installations to accommodate new construction.

5. Where a complete system is indicated to be removed, remove the exposed electrical equipment and installations in their entirety.
6. Remove, store, clean, reinstall, reconnect, and make operational components indicated for relocation.

B. Protection of existing components that are to remain:

1. Protect existing electrical equipment and installations indicated to remain. If damaged or disturbed in the course of the Work, remove damaged portions and install new products of equal capacity, quality, and functionality.
2. Maintain access to existing electrical installations that remain active. Modify installation or provide access panel as appropriate.
3. Where an existing electrical system (feeder, control wiring, or branch circuit to any existing panel, appliance, mechanical component, or any other electrical device that is to remain) passes through a demolition area, maintain the existing system in operation using materials and methods compatible with the existing electrical installations, or as specified.
4. Where an existing conduit is re-used, re-support existing conduit as required by NFPA 70 and as outlined elsewhere in these specifications. Existing conduits shall be supported in a manner compliant with requirements specified elsewhere in these specifications.
5. Where an existing conduit that remains is supported by an existing ceiling scheduled for demolition, re-support the conduit in a manner compliant with requirements specified elsewhere in these specifications.

C. Abandoned Work:

1. In demolition areas, cut and remove raceways below the surface of adjacent construction. Cap raceways and patch surface to match existing finish.
2. Remove exposed abandoned conduit, including abandoned conduit above accessible ceilings in the remodeled areas.
3. Remove abandoned wiring to source of supply and mark overcurrent device as spare (if it is to remain).
4. Remove all disconnected or abandoned existing outlets including telephone, data, receptacle, television and other miscellaneous system outlets.
5. Disconnect and remove low voltage systems not being reused.
6. Where an existing device is indicated to be removed (or existing system device is required to be removed) from an existing wall that is to remain, provide a blank coverplate to match other plates installed in the room. Existing wiring shall remain where wiring passes through to other existing devices that are to remain. Remove abandoned wiring where not installed with existing wiring that is required to remain. Existing raceway systems concealed in walls, floors, or above inaccessible ceilings may be abandoned in place.

3.4 HAZARDOUS MATERIALS

- A. Review requirements for hazardous materials in Division 1 Specification Section.

3.5 FLUORESCENT LAMP BALLAST AND FLUORESCENT LAMP DISPOSAL

- A. General:

1. The work required consists of providing disposal for all fluorescent lamp ballasts and fluorescent lamps removed from existing lighting fixtures for this project.
 - a. Since it is impractical to determine the exact number, type and conditions of all the existing fluorescent lamp ballasts which are to be disposed, for bidding purposes the contractor shall consider all existing fluorescent lamp ballasts which are to be disposed as PCB/DEHP containing and non-leaking. The contractor shall be responsible for sorting types of ballasts in the field and for the appropriate disposal of those ballasts as specified herein.
 2. All fluorescent lamp ballasts and fluorescent lamps shall be disposed of and recycled by a single firm experienced and specializing in this work, such as; Lighting Resources, Inc., 498 Park 800 Drive, Greenwood, IN 46143. Phone No: 317-888-3889. Sub-letting of any portion of the fluorescent lamp ballast and fluorescent lamp disposal work shall not be permitted.
 3. The fluorescent lamp ballast and fluorescent lamp disposal firm shall have an Environmental Protection Agency identification number. This number shall be furnished to the Engineer.
 4. The fluorescent lamp ballast and fluorescent lamp disposal firm shall have an appropriate level of documented and followed safety and environmental policies and procedures. Minimally this shall include a written safety program, documented employee training and regular documented inspections of environmental requirements. A copy of these policies and procedures shall be furnished to the Engineer, an additional two (2) copies, one copy for the Owner's records and one copy for the Architect's records, shall be submitted with the shop drawings.
 5. The fluorescent lamp ballast and fluorescent lamp disposal firm shall be capable of exhibiting employee training, general and environmental impairment liability insurance and have the experience to properly manage PCB/DEHP lighting ballasts and fluorescent lamps.
- B. Disposal of non-leaking PCB/DEHP containing ballasts:
1. Lighting ballasts containing polychlorinated biphenyls (PCBs) or di (2-ethylhexyl) phthalate (DEHP) and are not leaking shall be disposed of in the following manner:
 - a. Remove the ballast from the lighting fixtures, cut-off the lead wires and properly store ballasts in the approved D.O.T. drums. The drums shall be properly labeled with D.O.T. approved 6" x 6" yellow and black, PCB labels. Drums shall be stored indoors in a secured area.
 - b. Ship the lamps to the fluorescent lamp ballast and fluorescent lamp disposal firm utilizing Uniform Hazardous Waste Manifests or Bill of Lading. Provide two (2) copies of all Uniform Hazardous Waste Manifests or Bills of Lading, one copy for the Owner's records and one copy for the Engineer's records.
 - c. The fluorescent lamp ballast and fluorescent lamp disposal firm shall:
 - 1) Strip ballasts of all recyclable materials for recycling.
 - 2) Remove all PCB/DEHP containing materials from the ballasts and ship them to an EPA approved incinerator. Provide copies of shipping documentation for the Owner's and Architect's records
 - 3) All PCB/DEHP containing materials shall be incinerated completely in the EPA approved incinerator.
 - d. Ballasts shall not be disposed of in trash or dumpsters.

- e. Ballasts shall not be disposed of by burial in a landfill.
 - f. Ballasts shall be completely disposed of within 60 days of shipment of the ballasts to the fluorescent lamp ballast and fluorescent lamp disposal firm.
2. Upon completion of the PCB/DEHP ballast disposal process, provide the following documentation.
 - a. A copy of the Uniform Hazardous Waste Manifest or Bill of Lading for shipment of the PCB/DEHP ballasts to the fluorescent lamp ballast and fluorescent lamp disposal firm.
 - b. A copy of the Uniform Hazardous Waste Manifest or Bill of Lading for shipment of the PCB/DEHP containing materials from the fluorescent lamp ballast and fluorescent lamp disposal firm to the EPA approved incinerator.
 - c. Provide two (2) copies of each Uniform Hazardous Waste Manifest required in B.1. and B.2. above; one (1) copy for the Owner's records and one (1) copy for the Engineer's records.
 - d. With each Uniform Hazardous Waste Manifest to be provided above, provide a letter of explanation which will show each site with respective quantities from which materials shipped under that Manifest originated.

NOTE: The intent of this letter is to help to provide adequate documentation so the original materials may be tracked from their removal from the Owner's site to final disposal.

3. A "Certificate of Destruction" which will show the date and location where the PCB/DEHP containing materials were incinerated as well as the EPA ID number of the incinerator and the quantities of PCB/DEHP material from the Owner incinerated. Provide one original copy for the Owner's records and one copy for the Engineer's records.
4. Certification that the non-PCB/DEHP containing components of the ballasts have been properly recycled. The quantities of materials from the Owner which were recycled shall be shown. Provide one original copy for the Owner's records and one copy for the Engineer's records.

C. Disposal of leaking PCB/DEHP containing ballasts:

1. Ballasts which contain PCB/DEHP materials and are leaking shall be disposed of as specified for non-leaking PCB/DEHP containing ballasts except:
 - a. The ballasts, once removed from the lighting fixtures, shall be double wrapped in plastic bags and stored in separate D.O.T. approved drums.
 - b. The entire ballast shall be shipped to an EPA approved incinerator utilizing Uniform Hazardous Waste Manifests or Bill of Lading. Provide two (2) copies of Uniform Hazardous Waste Manifest or Bill of Lading, one copy for the Owner's records and one copy for the Engineer's records.
 - c. The entire ballast shall be incinerated completely in the EPA approved incinerator.
2. Upon completion of disposal of the leaking PCB/DEHP ballasts provide a "Certificate of Destruction" which will show the date and location where the leaking PCB/DEHP ballasts were incinerated as well as the EPA ID number of the incinerator. Provide one original copy for the Owner's records and one copy for the Engineer's records.

D. Disposal of non-PCB/DEHP containing ballasts:

1. Lighting ballasts which do not contact PCB or DEHP materials shall be disposed of in the following manner:
 - a. Remove the ballast from the lighting fixture, cut off the lead wires and properly store ballasts in approved D.O.T. drums. Drums shall be stored indoors in a secured area.
 - b. Ship ballasts to the fluorescent lamp ballast and fluorescent lamp disposal firm.
 - c. The fluorescent lamp ballast and fluorescent lamp disposal firm shall recycle all recyclable materials from ballasts.
 - d. Ballasts shall not be disposed of in trash or dumpsters.
 - e. Ballasts shall not be disposed of by burial in a landfill.
 - f. Ballasts shall be completely disposed of within 60 days of shipment of the ballasts to the fluorescent lamp ballast and fluorescent lamp disposal firm.
 2. Upon completion of disposal of NON-PCB/DEHP containing ballasts, provide certification that the ballasts have been properly recycled including location, date and EPA ID number of the recycler. Provide one original copy for the Owner's records and one copy for the Engineer's records.
- E. Disposal of fluorescent lamps:
1. Fluorescent lamps shall be disposed of in the following manner:
 - a. Remove fluorescent lamps intact from the lighting fixture and place lamps into new or used lamp boxes (supplied by fluorescent lamp ballast and fluorescent lamp disposal firm) and tape the ends of the boxes shut once full.
 - b. Store the boxes of lamps indoors in a dry secured area. Do not stack boxes of lamps more than 66 inches high as the bottom lamps will crush.
 - c. Ship the lamps to the fluorescent lamp ballast and fluorescent lamp disposal firm utilizing Uniform Hazardous Waste Manifests or Bill of Lading. Provide two (2) copies of all Uniform Hazardous Waste Manifests or Bills of Lading, one copy for the Owner's records and one copy for the Engineer's records.
 - d. The fluorescent lamp ballast and fluorescent lamp disposal firm shall:
 - 1) Recycle all recyclable materials in the fluorescent lamps including retorting the mercury contained in the phosphor powder of the lamps.
 - e. Lamps shall not be crushed or broken.
 - f. Lamps shall not be disposed of in trash or in dumpsters.
 - g. Lamps shall not be disposed of by burial in a landfill.
 - h. Fluorescent lamps shall be completely disposed of within 60 days of shipment of the fluorescent lamps to the fluorescent lamp ballast and fluorescent lamp disposal firm.
 2. Upon completion of the disposal of the fluorescent lamps, provide certification that the lamps have been properly recycled including location, date and EPA ID number of the recycler. Provide one original copy for the Owner's records and one copy for the Engineer's records.

3.6 CUTTING AND PATCHING

- A. Cut, channel, chase, and drill floors, walls, partitions, ceilings, and other surfaces required permitting electrical installations. Perform cutting by skilled mechanics of trades involved.
- B. Repair and refinish disturbed finish materials and other surfaces to match adjacent undisturbed surfaces. Install new fireproofing where existing firestopping has been disturbed. Repair and refinish materials and other surfaces by skilled craftsman of trades involved.

3.7 REFINISHING AND TOUCHUP PAINTING

- A. Surface preparation, refinish and touchup paint as indicated in Division 9 Section "Painting" and in Part 2 of this specification.

3.8 CLEANING AND PROTECTION

- A. On completion of demolition, inspect exposed finish of existing electrical items that are to remain in service. For all electrical equipment that was altered, moved, or worked on during construction, remove burrs, dirt, paint spots, and construction debris.
- B. Protect existing equipment and installations of existing items that are to remain and maintain conditions to ensure that coatings, finishes, and cabinets are without damage or deterioration at time of Substantial Completion.
- C. Panelboards: Clean exposed surfaces and check tightness of electrical connections. Replace damaged circuit breakers and provide closure plates for vacant positions. Provide typed circuit directory showing revised circuiting arrangement.

END OF SECTION 260006

SECTION 260526 - GROUNDING AND BONDING FOR ELECTRICAL SYSTEMS

PART 1 - GENERAL

1.1 RELATED DOCUMENTS

- A. Drawings and general provisions of the Contract, including General and Supplementary Conditions and Division 01 Specification Sections, apply to this Section.

1.2 SUMMARY

- A. This Section includes methods and materials for all grounding and bonding of systems and equipment as follows:
 - 1. All required secondary grounding.
 - 2. Miscellaneous grounding as required by NFPA 70, National Electrical Code.
 - 3. All bonding as required by NFPA 70, National Electrical Code, Article 250.

1.3 SUBMITTALS

- A. Product Data: For each type of product indicated.
- B. Field quality-control test reports.

1.4 QUALITY ASSURANCE

- A. Electrical Components, Devices, and Accessories: Listed and labeled as defined in NFPA 70, Article 100, by a testing agency acceptable to authorities having jurisdiction, and marked for intended use.
- B. Comply with UL 467 for grounding and bonding materials and equipment.

PART 2 - PRODUCTS

2.1 CONDUCTORS

- A. Insulated Conductors: Copper wire or cable insulated for 600 V unless otherwise required by applicable Code or authorities having jurisdiction.

PART 3 - EXECUTION

3.1 APPLICATIONS

- A. General: Except where otherwise shown or noted, all grounding conductors shall be insulated and enclosed in a raceway. Bare conductors will not be permissible except where located used for Ufer Ground (Concrete-Encased Grounding Electrode).
- B. Conductors: Install solid conductor for No. 8 AWG and smaller, and stranded conductors for No. 6 AWG and larger, unless otherwise indicated.
- C. Grounding Bus:
 - 1. Install in rooms where as indicated.
 - a. Install bus on insulated spacers 1 inch (25 mm), minimum, from wall 6 inches (150 mm) above finished floor, unless otherwise indicated.
 - b. Where indicated on both sides of doorways, route bus up to top of door frame, across top of doorway, down to specified height above floor, and connect to horizontal bus.

3.2 EQUIPMENT GROUNDING

- A. Install insulated equipment grounding conductors in conduit with all feeders and branch circuits.
- B. Install insulated equipment grounding conductors with the following items, in addition to those required by NFPA 70, National Electrical Code:
 - 1. Branch circuits:
 - a. Size grounding conductors in accordance with NFPA 70, National Electrical Code; Table 250.122.
 - b. Branch Circuits: Bond conductor at each termination.
 - 2. Lighting Fixtures:
 - a. Suspended Lighting Fixtures: Install separate grounding conductor from outlet box to fixture wireway. Flexible conduit meeting the requirements of NFPA 70; National Electrical Code; Article 250.118 shall be permitted without additional ground wire for lighting fixtures only.
 - b. Recessed and Surface Mounted Lighting Fixtures: A separate grounding conductor shall not be required where the fixture is mechanically connected in a permanent and effective manner as specified in NFPA 70, National Electrical Code; Article 250.
 - 3. Receptacles: Install self-grounding type receptacles in all locations. Provide Raco #983 series or equal grounding pigtail from box to receptacle. Provide wired ground where required for isolation of positive grounding
 - 4. Single-phase motor and appliance branch circuits.
 - 5. Three-phase motor and appliance branch circuits.
 - 6. Flexible raceway runs.
 - 7. Armored and metal-clad cable runs.

8. Surface Metal Raceway: Install a grounding conductor from the connected to the nearest bonding bushing or conduit box originating at supply panel and connected to grounding screw on each receptacle in the raceway. The grounding conductor shall be continuous without breaks.

3.3 INSTALLATION

- A. Grounding Conductors: Route along shortest and straightest paths possible, unless otherwise indicated or required by Code. Avoid obstructing access or placing conductors where they may be subjected to strain, impact, or damage.
- B. Bonding Straps and Jumpers: Install in locations accessible for inspection and maintenance, except where routed through short lengths of conduit.
- C. Grounding and Bonding for Conduits: Install double locknuts on all Rigid Metal Conduit (RMC) and Intermediate Metal Conduit (IMC).

3.4 FIELD QUALITY CONTROL

- A. Perform the following tests and inspections and prepare test reports:
 1. After installing grounding system but before permanent electrical circuits have been energized, test for compliance with requirements.
 2. Test completed grounding system at each location where a maximum ground-resistance level is specified, at service disconnect enclosure grounding terminal at individual ground rods. Make tests at ground rods before any conductors are connected.
 - a. Measure ground resistance not less than two full days after last trace of precipitation and without soil being moistened by any means other than natural drainage or seepage and without chemical treatment or other artificial means of reducing natural ground resistance.
 - b. Perform tests by fall-of-potential method according to IEEE 81.
- B. Report measured ground resistances that exceed the following values:
 1. Power and Lighting Equipment or System with Capacity 500 kVA and Less: 10 ohms.
- C. Excessive Ground Resistance: If resistance to ground exceeds specified values, notify Architect promptly and include recommendations to reduce ground resistance.

END OF SECTION 260526

SECTION 260529 - HANGERS AND SUPPORTS FOR ELECTRICAL SYSTEMS

PART 1 - GENERAL

1.1 RELATED DOCUMENTS

- A. Drawings and general provisions of the Contract, including General and Supplementary Conditions and Division 01 Specification Sections, apply to this Section.

1.2 SUMMARY

- A. This Section includes the following:
 - 1. Hangers and supports for electrical equipment and systems.
- B. Related Sections include the following:
 - 1. Division 26 Section "Common Work Results for Electrical" for products and installation for concrete and grout necessary for electrical installations.

1.3 DEFINITIONS

- A. Electroplated: Steel zinc coated by immersion into a solution of zinc ions and application of an electric current conforming to ASTM B633 Type III SC1.
- B. Pregalvanized: Steel zinc coated by a hot dip process conforming to G-90 thickness designation per ASTM A653 prior to fabrication of the part into final form; zinc thickness of 0.75 MIL.

1.4 PERFORMANCE REQUIREMENTS

- A. Design supports for multiple raceways capable of supporting combined weight of supported systems and its contents.
- B. Design equipment supports capable of supporting combined operating weight of supported equipment and connected systems and components.
- C. Rated Strength: Adequate in tension, shear, and pullout force to resist maximum loads calculated or imposed for this Project, with a minimum structural safety factor of five (5) times the applied force.

1.5 SUBMITTALS

- A. Product Data: For the following:
 - 1. Steel slotted support systems.

- B. Shop Drawings: Show fabrication and installation details and include calculations for the following:
 - 1. Trapeze hangers. Include Product Data for components.
 - 2. Steel slotted channel systems. Include Product Data for components.
 - 3. Equipment supports.
- C. Welding certificates.

1.6 QUALITY ASSURANCE

- A. Welding: Qualify procedures and personnel according to AWS D1.1/D1.1M, "Structural Welding Code - Steel."
- B. Comply with NFPA 70.

1.7 COORDINATION

- A. Coordinate installation of roof curbs, equipment supports, and roof penetrations. These items are specified in Division 07 Section "Roof Accessories."

PART 2 - PRODUCTS

2.1 STEEL SLOTTED SUPPORT SYSTEMS

- A. General: Comply with MFMA-4, factory-fabricated components for field assembly.
- B. Manufacturers: Subject to compliance with requirements, provide products by one of the following:
 - 1. Cooper B-Line, Inc.; a division of Cooper Industries.
 - 2. ERICO International Corporation.
 - 3. GS Metals Corp.
 - 4. Thomas & Betts Corporation.
 - 5. Unistrut; Tyco International, Ltd.
- C. Fabrication:
 - 1. Channel Materials: 12 Ga. (2.7 mm) minimum structural grade steel conforming to ASTM A653 GR 33.
 - 2. Hardware Materials: Steel conforming to ASTM A575, A576, A36 or A635.
 - 3. Metallic Coatings:
 - a. Steel Slotted Channel: Pregalvanized zinc coating.
 - b. Hardware: Electroplated zinc coating.
 - 4. Channel Dimensions: 1-5/8" wide by 1-5/8" high minimum size increased as required for applicable load data..

2.2 RACEWAY SUPPORTS

A. General:

1. As described in NECA 1 and NECA 101.
2. Conduit and Cable Support Devices: Steel and malleable-iron hangers, clamps, and associated fittings, designed for types and sizes of raceway or cable to be supported.
3. Support for Conductors in Vertical Conduit: Factory-fabricated assembly consisting of threaded body and insulating wedging plug or plugs for non-armored electrical conductors or cables in riser conduits. Plugs shall have number, size, and shape of conductor gripping pieces as required to suit individual conductors or cables supported. Body shall be malleable iron.

B. Manufacturers: Subject to compliance with requirements, provide products by the following:

1. Cooper B-Line, Inc.; a division of Cooper Industries.
2. ERICO International Corporation.
3. GS Metals Corp.
4. Thomas & Betts Corporation.
5. Unistrut; Tyco International, Ltd.

C. Surface Mounted Raceways:

1. Above Interior Ceilings: One-hole zinc plated steel straps with one bolt.
 - a. EMT: Equal to Thomas and Betts #TS-101 through #TS-106 Series and #HS-107 through #HS-110 Series.
 - b. IMC and RMC: Equal to Thomas and Betts #HS-101 through #HS-110 Series.
2. Exterior, Exposed on Concrete, and Tunnel Walls: Zinc Plated one-hole malleable iron with matching spacer.
 - a. Equal to Thomas and Betts #HS-401 through #HS-410 Series.

D. Suspended Raceways:

1. Individual Raceways: Zinc plated steel conduit clamp with bolt and nut.
 - a. Equal to Erico #CDXB Series.
2. Multiple "Trapeze Hung" Raceways: Zinc plated split pipe clamp with bolt and nut.
 - a. EMT: Equal to Unistrut #P1425 through #P1431 Series and #P1118 through #P1121 Series.
 - b. IMC and RMC: Equal to Unistrut #P1111 through #P1121 Series.

2.3 MOUNTING, ANCHORING, AND ATTACHMENT COMPONENTS

A. General: Provide items for fastening electrical items or their supports to building surfaces.

- B. Mechanical-Expansion Anchors: Insert-wedge-type, zinc-coated steel, for use in hardened portland cement concrete with tension, shear, and pullout capacities appropriate for supported loads and building materials in which used.
 - 1. Manufacturers: Subject to compliance with requirements, provide products by one of the following:
 - a. Cooper B-Line, Inc.; a division of Cooper Industries.
 - b. Empire Tool and Manufacturing Co., Inc.
 - c. Hilti Inc.
 - d. ITW Ramset/Red Head; a division of Illinois Tool Works, Inc.
 - e. MKT Fastening, LLC.
- C. Concrete Inserts: Steel or malleable-iron, slotted support system units similar to MSS Type 18; complying with MFMA-4 or MSS SP-58.
- D. Clamps for Attachment to Steel Structural Elements: MSS SP-58, type suitable for attached structural element.
- E. Through Bolts: Structural type, hex head, and high strength. Comply with ASTM A 325.
- F. Toggle Bolts: All-steel springhead type.
- G. Hanger Rods: Threaded low carbon zinc plated steel.

PART 3 - EXECUTION

3.1 APPLICATION

- A. Comply with NECA 1 and NECA 101 for application of hangers and supports for electrical equipment and systems except if requirements in this Section are stricter.
- B. Maximum Support Spacing for Raceway: Space supports for raceways as follows and required by NFPA 70.
 - 1. Support maximum 5'-0" for raceways 1" and smaller.
 - 2. Support maximum 8'-0" for raceways larger than 1".
- C. Minimum Hanger Rod Size for Raceway: Supports for all suspended conduits shall be from threaded rod, minimum threaded rod size shall be 1/4 inch (6 mm) in diameter.
- D. Multiple Raceways: Install trapeze-type supports fabricated with steel slotted support system, sized so capacity can be increased by at least 25 percent in future without exceeding specified design load limits.
 - 1. Secure raceways and cables to these supports with pipe clamps.
- E. The use of powder actuated fasteners is prohibited.

3.2 SUPPORT INSTALLATION

- A. Comply with NECA 1 and NECA 101 for installation requirements except as specified in this Article.
- B. Raceway Support Methods: In addition to methods described in NECA 1, raceways may not be supported solely by openings through structure members. To clarify; every raceway shall be supported by means of a mechanical fasteners 3' or less from every termination and prior to being routed through a structural member from a box or termination point. The requirements as permitted in NFPA 70 for supporting conduits are permissible as long as the requirements are met as stated here.
- C. Strength of Support Assemblies: Where not indicated, select sizes of components so strength will be adequate to carry present and future static loads within specified loading limits. Minimum static design load used for strength determination shall be weight of supported components plus 200 lb (90 kg).
- D. Mounting and Anchorage of Surface-Mounted Equipment and Components: Anchor and fasten electrical items and their supports to building structural elements by the following methods unless otherwise indicated by code:
 - 1. To Wood: Fasten with lag screws or through bolts.
 - 2. To New Concrete: Bolt to concrete inserts.
 - 3. To Masonry: Approved toggle-type bolts on hollow masonry units and expansion anchor fasteners on solid masonry units.
 - 4. To Existing Concrete: Expansion anchor fasteners.
 - 5. To Steel: Beam clamps (MSS Type 19, 21, 23, 25, or 27) complying with MSS SP-69.
 - 6. To Light Steel: Sheet metal screws.
 - 7. Items Mounted on Hollow Walls and Nonstructural Building Surfaces: Mount cabinets, panelboards, disconnect switches, control enclosures, pull and junction boxes, transformers, and other devices on slotted-channel racks attached to substrate.
- E. Drill holes for expansion anchors in concrete at locations and to depths that avoid reinforcing bars.

3.3 INSTALLATION OF FABRICATED METAL SUPPORTS

- A. Comply with installation requirements in Division 05 Section "Metal Fabrications" for site-fabricated metal supports.
- B. Cut, fit, and place miscellaneous metal supports accurately in location, alignment, and elevation to support and anchor electrical materials and equipment.
- C. Field Welding: Comply with AWS D1.1/D1.1M.

3.4 PAINTING

- A. Touchup: Comply with requirements in Division 09 painting Sections for cleaning and touchup painting of field welds, bolted connections, and abraded areas of shop paint on miscellaneous metal.

- B. Galvanized Surfaces: Clean welds, bolted connections, and abraded areas and apply galvanizing-repair paint to comply with ASTM A 780.

END OF SECTION 260529

SECTION 260533 – RACEWAYS AND FITTINGS

PART 1 - GENERAL

1.1 RELATED DOCUMENTS

- A. Drawings and general provisions of the Contract, including General and Supplementary Conditions and Division 01 Specification Sections, apply to this Section.

1.2 SUMMARY

- A. This Section includes raceways, wireways and fittings for electrical wiring.
- B. Related Sections include the following:
 - 1. Division 26 Section “Boxes and Enclosures”.

1.3 DEFINITIONS

- A. EMT: Electrical Metallic Tubing: An unthreaded thinwall raceway of circular cross section designed for the physical protection and routing of conductors and cables and for use as an equipment grounding conductor when installed utilizing appropriate fittings.
 - 1. Steel (ferrous) with protective coatings.
 - 2. NFPA 70, National Electrical Code, Article 358.
- B. RMC: Rigid Metal Conduit: A threadable raceway of circular cross section designed for the physical protection and routing of conductors and cables and for use as an equipment grounding conductor when installed with its integral or associated coupling and appropriate fittings.
 - 1. Steel (ferrous) with protective coatings.
 - 2. NFPA 70, National Electrical Code, Article 344.
- C. FMC: Flexible Metal Conduit: A raceway of circular cross section made of helically wound, formed, interlocked metal strip.
 - 1. NFPA 70, National Electrical Code, Article 348.
- D. LFMC: Liquidtight Flexible Metal Conduit: A raceway of circular cross section having an outer jacket over an inner flexible metal core with associated couplings, connectors, and fittings for the installation of electric conductors.
 - 1. NFPA 70, National Electrical Code, Article 350.

1.4 SUBMITTALS

- A. Product Data: For conduits, wireways, and fittings.
- B. Shop Drawings: For the following raceway components. Include plans, elevations, sections, details, and attachments to other work.
 - 1. Custom enclosures and cabinets.
- C. Coordination Drawings: Conduit routing plans, drawn to scale, on which the following items are shown and coordinated with each other, based on input from installers of the items involved:
 - 1. Structural members in the paths of conduit groups with common supports.
 - 2. HVAC and plumbing items and architectural features in the paths of conduit groups with common supports.

1.5 QUALITY ASSURANCE

- A. Electrical Components, Devices, and Accessories: Listed and labeled as defined in NFPA 70, Article 100, by a testing agency acceptable to authorities having jurisdiction, and marked for intended use.
- B. Comply with NFPA 70.

PART 2 - PRODUCTS

2.1 METAL CONDUIT AND TUBING

- A. Manufacturers: Subject to compliance with requirements, provide products by one of the following of U.S. manufacture only:
 - 1. Allied Tube & Conduit; a Tyco International Ltd. Co.
 - 2. Anamet Electrical, Inc.; Anaconda Metal Hose.
 - 3. Electri-Flex Co.
 - 4. O-Z Gedney.
 - 5. Republic Corporation.
 - 6. Western Tube and Conduit Corporation.
 - 7. Wheatland Tube Company.
- B. Conduits:
 - 1. Electrical Metallic Tubing (EMT): Conduit shall:
 - a. Be listed per UL 797.
 - b. Comply with ANSI C80.3.
 - c. Be steel with electro-galvanized zinc exterior coating.
 - d. Have lacquer coating on interior.
 - 2. Rigid Metal Conduit (RMC): Conduit shall:

- a. Be listed per UL 6.
 - b. Comply with ANSI C80.1.
 - c. Be steel with hot-dipped galvanized exterior coating.
 - d. Have enamel or lacquer coating on interior.
 3. Flexible Metal Conduit (FMC): Conduit shall:
 - a. Be listed per UL 1.
 - b. Be steel with hot-dipped galvanized exterior coating.
 - c. Have interlocking design.
 4. Liquidtight Flexible Metal Conduit (LFMC): Conduit shall:
 - a. Be listed per UL 360.
 - b. Be steel with hot-dipped galvanized exterior coating.
 - c. Have interlocking design.
 - d. Have moisture, oil, and sunlight resistant overall outer PVC jacket.
- C. Conduit Fittings:
 1. General:
 - a. NEMA FB 1; listed for type and size raceway with which used, and for application and environment in which installed
 2. Electrical Metallic Tubing (EMT): Fittings for use with EMT shall:
 - a. Be listed per UL 514B.
 - b. Be electroplated steel set screw type, concrete tight couplings and connectors.
 - c. Be OZ/Gedney #4000/5000 Series or equal of Appleton or Thomas & Betts.
 - d. Be furnished with insulated throats for connectors when used for conductors #6 AWG and larger.
 3. Flexible Metal Conduit (FMC): Fittings for use with FMC shall:
 - a. Be UL listed for grounding.
 - b. Be squeeze type, malleable iron with one or two screws; set screw, die-cast or screw-in type fittings will not be acceptable.
 4. Liquidtight Flexible Metal Conduit (LFMC): Fittings for use with LFMC shall:
 - a. Be UL listed for grounding.
 - b. Be ferrule and sleeve type with hot-dipped galvanized malleable iron body and zinc electroplated steel ferrule.
 - c. Be liquidtight, raintight, oiltight and concretetight.
 - d. Have insulated throat.

2.2 METAL WIREWAYS

- A. Available Manufacturers: Subject to compliance with requirements, manufacturers offering products that may be incorporated into the Work include, but are not limited to, the following:

- B. Manufacturers: Subject to compliance with requirements, provide products by one of the following:
 - 1. Cooper B-Line, Inc.
 - 2. Hoffman.
 - 3. Square D; Schneider Electric.
- C. Description: Sheet metal sized and shaped as indicated, NEMA 250, Type 1, unless otherwise indicated.
- D. Fittings and Accessories: Include couplings, offsets, elbows, expansion joints, adapters, hold-down straps, end caps, and other fittings to match and mate with wireways as required for complete system.
- E. Wireway Covers: Screw-cover type, or as indicated.
- F. Finish: Manufacturer's standard enamel finish.

2.3 SLEEVES FOR RACEWAYS

- A. Steel Pipe Sleeves: ASTM A 53/A 53M, Type E, Grade B, Schedule 40, galvanized steel, plain ends.
- B. Sleeves for Rectangular Openings: Galvanized sheet steel with minimum 0.052- or 0.138-inch (1.3- or 3.5-mm) thickness as indicated and of length to suit application.
- C. Coordinate sleeve selection and application with selection and application of firestopping specified in Division 7 Section "Firestopping."

2.4 CONDUIT FITTINGS

- A. Conduit Fittings:
 - 1. Cast ferrous for exterior, watertight, vaportight and similar locations with gaskets for covers.
 - 2. "LBD" and mogul size required for 1" and larger conduits.
 - 3. As manufactured by Appleton, Crouse Hinds, Killark or Pyle National.
- B. Expansion Fittings:
 - 1. Furnished complete with bonding straps.
 - 2. Selected by manufacturer for each specific application for the correct movement required.
 - 3. As manufactured by O.Z./Gedney or approved equal.

PART 3 - EXECUTION

3.1 GENERAL RACEWAY APPLICATION

- A. All conductors for each and every electrical system shall be installed in a raceway.

- B. Minimum Allowable Sizes (increased as necessary for installation conditions):
1. $\frac{3}{4}$ " minimum except $\frac{1}{2}$ " will be permitted for:
 - a. Runs in 4" masonry walls.
 - b. Motor control circuits.
 - c. Motor power circuits.
 - d. Switch legs to single switches.
 - e. End of run devices (dead end – one conduit only).
 2. $\frac{1}{2}$ " minimum will be permitted for FMC except where $\frac{3}{8}$ " is permitted for light fixture whips.
- C. Separate conduit systems shall be provided for the following:
1. Each lighting system.
 2. Convenience outlets.
 3. Each power system.
 4. Each feeder and equipment branch circuit.
 5. Special and different systems such as normal power, emergency power, low voltage systems, sound systems, telecommunications systems, control systems, etc.
- D. Common Conduits: Permitted for
1. Branch circuits originating from the same panel for lighting and receptacles or motor circuits.
 2. Motor circuits and its associated control wiring.
- E. All conduits shall be concealed in new and/or existing building finishes except as permitted below:
1. Electrical and mechanical spaces.
 2. Where specifically noted otherwise on the drawings or permitted by the Engineer.
- F. All conduits for this project are generally indicated on the drawings to be run in space above suspended ceilings with drops down to devices flush in the walls to permit partitions to be revised in the future without regard to conduit stub-ups from the floor slab to outlets.

3.2 SPECIFIC RACEWAY APPLICATION

- A. Electrical Metallic Tubing (EMT); Apply raceway products as follows:
1. For use in interior masonry and other wall construction except poured concrete.
 2. For use above ceilings.
 3. For use up a maximum 1-1/4" allowable size except where specifically permitted otherwise.
- B. Rigid Metal Conduit (RMC); Apply raceway products as follows:
1. For all conduits 1-1/2" size and larger except where permitted otherwise in these specifications.
 2. For use in concrete and poured walls; 1" minimum cover required.

3. For use in all exposed exterior locations.
4. For use for all feeder conduits.
5. For use in all exterior masonry construction.
6. For use where exposed to mechanical injury.
7. For use in all Hazardous (Classified) locations as defined by NFPA 70; National Electrical Code, Chapter 5.
8. For use for all "vaportight" and "watertight" installations.
9. For use on or within all laboratory equipment and furniture except where noted and/or approved otherwise by the Engineer.
10. For use where entering or exiting a concrete slab; extend a minimum of 36" before adapting to another conduit type permitted for the application.
11. Install continuous where connecting to a junction box or enclosure within 60" of entering or exiting a concrete slab.

C. Flexible Metal Conduit (FMC); Apply raceway products as follows:

1. For final connections to transformers and vibrating equipment; 3' maximum length permitted.
2. For final connections to all motors; 3' maximum length permitted.
 - a. FMC shall be supported within 3' of motor.
3. For final connections to all recessed luminaires (light fixtures); 6' maximum length.
 - a. Length of FMC shall be adequate for servicing and convenient removal.
 - b. FMC shall be supported within 6' of fixture.

D. Liquidtight Flexible Metal Conduit (LFMC); Apply raceway products as follows:

1. To be provided in lieu of FMC in damp and wet locations including but not limited to exterior locations, connection to water softener, and equipment located within air chamber of air handling equipment.

3.3 INSTALLATION

- A. Comply with NECA 1 for installation requirements applicable to products specified in Part 2 except where requirements on Drawings or in this Article are stricter.
- B. Coordinate all conduit locations with other trades prior to rough-in.
- C. Keep raceways at least 6 inches (150 mm) away from parallel runs of flues and steam or hot-water pipes. Install horizontal raceway runs above water and steam piping.
- D. Ream all conduits after cutting.
- E. Complete raceway installation before starting conductor installation.
- F. Support raceways as specified in Division 26 Section "Hangers and Supports for Electrical Systems."
- G. Arrange stub-ups so curved portions of bends are not visible above the finished slab.

- H. Install no more than the equivalent of three (3) 90-degree bends in any conduit run except for communications conduits, for which fewer bends are allowed.
- I. Install conduits such that there is a maximum of 100 feet between pulling points in any conduit run except for communications conduits, for which decreased pulling distance is allowed.
- J. Conceal conduit and EMT within finished walls and ceilings unless otherwise indicated.
- K. Run exposed conduits parallel and plumb with adjacent surfaces.
- L. All conduit bends shall be as specified in the National Electrical Code except where long sweeps are required for special installation conditions.
- M. Hickey bends will not be acceptable and are not permitted for 1- $\frac{1}{4}$ " and larger conduits.
- N. All ends of conduits shall butt solidly in couplings.
- O. Raceway Terminations at Locations Subject to Moisture or Vibration: Use insulating bushings to protect conductors, including conductors smaller than No. 4 AWG.
- P. Install pull wires in empty raceways. Use polypropylene or monofilament plastic line with not less than 200-lb (90-kg) tensile strength. Leave at least 12 inches (300 mm) of slack at each end of pull wire.
- Q. Install expansion fittings of the proper type in each run of conduit that crosses a building expansion joint, outside or within structural slabs.
- R. Install raceway sealing fittings at suitable, approved, and accessible locations and fill them with listed sealing compound. For concealed raceways, install each fitting in a flush steel box with a blank cover plate having a finish similar to that of adjacent plates or surfaces. Install raceway sealing fittings at the following points:
 - 1. Where conduits pass between different temperature zones likely to cause condensation and circulation of moisture, such as boundaries of refrigerated spaces.
 - 2. Where conduits are installed in walls that enter/leave below grade.
 - 3. Where otherwise required by NFPA 70.
- S. Horizontal runs of conduit will not be permitted in stud walls.
- T. All conduit runs shall be securely fastened three feet from all termination points. Securely fastened shall mean that an additional support or caddy is installed within three feet of every box and before the conduit passes through any framing member. Framing members alone do not satisfy the term securely fastened.
- U. Open ends of conduits shall be protected during construction with Steel City "Space Caps" or equal to prevent entrance of foreign material and maintain spacing.

3.4 CONDUITS PENETRATING ROOFING

- A. Only one (1) conduit will be permitted to pass through a sleeve.

- B. Sleeve shall be installed such that the minimum height of the sleeve is not less than 8" above the roof membrane.
- C. Provide a rain shield on the conduit overlapping sleeve a minimum of 2 inches.
- D. The rain shield shall be secured to the conduit by means of stainless steel pressure clamps.
- E. Provide all flashing as required.

3.5 SLEEVE INSTALLATION FOR ELECTRICAL PENETRATIONS

- A. Coordinate sleeve selection and application with selection and application of firestopping specified in Division 7 Section "Firestopping."
- B. Concrete Slabs and Walls: Install sleeves for penetrations unless core-drilled holes or formed openings are used. Install sleeves during erection of slabs and walls.
- C. Use pipe sleeves unless penetration arrangement requires rectangular sleeved opening.
- D. Rectangular Sleeve Minimum Metal Thickness:
 - 1. For sleeve cross-section rectangle perimeter less than 50 inches (1270 mm) and no side greater than 16 inches (400 mm), thickness shall be 0.052 inch (1.3 mm).
 - 2. For sleeve cross-section rectangle perimeter equal to, or greater than, 50 inches (1270 mm) and 1 or more sides equal to, or greater than, 16 inches (400 mm), thickness shall be 0.138 inch (3.5 mm).
- E. Fire-Rated Assemblies: Install sleeves for penetrations of fire-rated floor and wall assemblies unless openings compatible with firestop system used are fabricated during construction of floor or wall.
- F. Cut sleeves to length for mounting flush with both surfaces of walls.
- G. Extend sleeves installed in floors 4 inches (100 mm) above finished floor level.
- H. Seal space outside of sleeves with grout for penetrations of concrete and masonry[and with approved joint compound for gypsum board assemblies].
- I. Interior Penetrations of Non-Fire-Rated Walls and Floors: Seal annular space between sleeve and raceway, using joint sealant appropriate for size, depth, and location of joint. Refer to Division 07 Section "Joint Sealants" for materials and installation.
- J. Fire-Rated-Assembly Penetrations: Maintain indicated fire rating of walls, partitions, ceilings, and floors at raceway penetrations. Install sleeves and seal with firestop materials. Comply with Division 7 Section "Firestopping."
- K. Roof-Penetration Sleeves: Seal penetration of individual raceways with flexible, boot-type flashing units applied in coordination with roofing work.

3.6 FIRESTOPPING

- A. Apply firestopping to electrical penetrations of fire-rated floor and wall assemblies to restore original fire-resistance rating of assembly. Firestopping materials and installation requirements are specified in Division 7 Section "Firestopping."

3.7 PROTECTION

- A. Provide final protection and maintain conditions that ensure coatings, finishes, and cabinets are without damage or deterioration at time of Substantial Completion.
 - 1. Repair damage to galvanized finishes with zinc-rich paint recommended by manufacturer.
 - 2. Repair damage to PVC or paint finishes with matching touchup coating recommended by manufacturer.

END OF SECTION 260533

SECTION 260534 – SURFACE METAL RACEWAYS

PART 1 - GENERAL

1.1 RELATED DOCUMENTS

- A. Drawings and general provisions of the Contract, including General and Supplementary Conditions and Division 1 Specification Sections, apply to this Section.
- B. Related Sections include the following:
 - 1. Division 26 Section "Basic Electrical Requirements".
 - 2. Division 26 Section "Raceways and Fittings".

1.2 GENERAL

- A. The work required under this section consists of furnishing and installing all surface metal raceways and fittings for the project.
- B. Surface metal raceways shall be used to provide power, lighting, control and/or communications distribution as shown on the drawings or as specified herein.
- C. All fittings shall be manufactured by the raceway manufacturer.
- D. All raceway installations shall be electrically continuous.
- E. All fittings shall be appropriate and suitable for their intended use.
- F. All joints shall be rigid and unyielding with horizontal or vertical pressure.
- G. Surface metal raceway to be used only where specifically indicated, or approved in writing by the Engineer.

1.3 SUBMITTALS

- A. Product Data: For each type of surface metal raceway, fitting, component, and accessory specified and/or required.

1.4 QUALITY ASSURANCE

- 1. All surface metal raceways shall be listed by Underwriters Laboratories in accordance with publication UL-5.
- 2. Comply with NFPA 70, National Electrical Code, Article 386.

PART 2 - PRODUCTS

2.1 ONE-PIECE ONE-CHANNEL SURFACE METAL RACEWAY

A. Manufacturers:

1. Design Basis Manufacturer:
 - a. Wiremold #500 or #700 Series.
2. Subject to compliance with requirements, provide products by one of the following:
 - a. Mono-Systems, Inc.
 - b. Hubbell.
 - c. Panduit.

B. Materials: The raceway and all system components shall be manufactured of zinc plated, galvanized steel and finished with ScuffCoat™ (a polyester topcoat over ivory base). Raceway shall be suitable for field painting.

1. Finish: Factory finished color for this project shall be manufacturer's standard ivory or white as selected by the Architect.

C. Raceway:

1. The raceway shall be a one-piece design with a base and cover factory assembled.
 - a. #500 Series: Raceway shall be 0.75" [19.05mm] wide by 0.53" [13.46mm] deep with a cross sectional area of 0.20 square inches [129mm²]. The raceway base and cover shall have an approximate thickness of .040" [10.16mm].
 - b. #700 Series: Raceway shall be 0.75" [19.05mm] wide by 0.66" [16.75mm] deep with a cross sectional area of 0.25 square inches [161.29mm²]. The raceway base and cover shall have an approximate thickness of .040" [10.16mm].
2. All field cuts shall be made by a hand operated cutting tool manufactured by the manufacturer of the raceway.

D. Fittings:

1. All fittings shall be suitable for use with the raceway including but not limited to the following
 - a. Mounting clips.
 - b. Couplings.
 - c. Flat, internal and external elbows.
 - d. Cover clips.
 - e. Tees.
 - f. Entrance fittings.
 - g. Conduit connectors and bushings.
2. All visible components of fittings shall be furnished with painted enamel finish to match the raceway installation.

E. Device and Fixture Boxes:

1. Device boxes shall be suitable for use with the raceway and for mounting standard devices and faceplates.
2. Device boxes shall include but not be limited to the following:
 - a. Single- and multiple-gang configurations up to six-gang.
 - b. Range in depth from 0.94" to 2.75" [23.88mm to 69.85mm].
 - c. Single-gang boxes shall allow for snap-on and fastener application.
 - d. Extension boxes shall adapt to existing standard flush switch and receptacle boxes.
 - e. Round fixture and extension boxes shall be suitable to mount fixtures and other devices with mounting centers of 1 15/32", 1 5/8", 1 23/32", 1 27/32", 2 3/4", 3 1/2", and 4 1/16" [37.34mm, 41.27mm, 43.69mm, 69.85mm, 88.90mm, and 103.17mm] diameters.
 - f. Round fixture and extension boxes shall have in depths ranging from 0.47" to 1.00" [11.94mm to 25.4mm] and in diameters of 3.00", 4.75", 5.50", and 6.38" [96.2mm, 120.65mm, 139.7mm, and 162.05mm].
3. All device and fixture box covers shall be furnished with painted enamel finish to match the raceway installation.

2.2 TWO-PIECE TWO-CHANNEL SURFACE METAL RACEWAY

A. Manufacturers:

1. Design Basis Manufacturer:
 - a. Wiremold #4000 Series.
2. Subject to compliance with requirements, provide products by one of the following:
 - a. Mono-Systems, Inc.
 - b. Hubbell.
 - c. Panduit.

B. Materials: The raceway and all system components shall be manufactured of zinc plated, galvanized steel and finished with ScuffCoat™ (a polyester topcoat over ivory base) or painted enamel finish. Raceway shall be suitable for field painting.

1. Finish: Factory finished color for this project shall be manufacturer's standard ivory or gray as selected by the Architect.

C. Raceway:

1. The raceway shall be a two-piece design with a base and snap-on cover.
 - a. The base and sections shall be a minimum of 0.050" [1.3mm] wall thickness.
 - b. The cover sections shall be a minimum of 0.040" [1.016mm] wall thickness.
 - c. Assembled base and cover shall be 4.75" [121mm] wide by 1.75" [45mm] high with a cross sectional area of 7.50square inches [5324mm²].

- d. The base shall be dividable by means of a removable barrier section that will divide the raceway into two equal sized compartments.
 2. All field cuts shall be made by a hand operated cutting tool manufactured by the manufacturer of the raceway.
- D. Fittings:
 1. All fittings shall be suitable for use with the raceway including but not limited to the following
 - a. Support clips.
 - b. Cover clips.
 - c. Wire clips.
 - d. Couplings.
 - e. Entrance fittings.
 - f. Flat, internal and external elbows.
 - g. Tees.
 - h. End caps.
 - i. Device mounting brackets.
 - j. Conduit connectors and bushings.
 2. All visible components of fittings shall be furnished with painted enamel finish to match the raceway installation.
- E. Device Brackets and Plates:
 1. Device brackets shall be suitable for mounting standard single- or two-gang devices either horizontally or vertically as required within the raceway.
 - a. Horizontal device brackets shall be provided with a single two-gang or a single four-gang cover plate as required.
 - b. Horizontal device mounting brackets shall be a single piece with two integral auxiliary grounding points provided.
 - c. Vertical device brackets shall be provided with a single two-gang or single four-gang cover plate.
 - d. Vertical device mounting brackets shall be a single piece with two integral auxiliary grounding points provided.
 - e. Devices both power and data/communication shall have the capacity of mounting flush or in conjunction with faceplates.
 - f. Faceplates shall conceal seam between raceway cover and installed faceplate.
 2. Devices shall have the capacity of mounting flush or in conjunction with standard faceplates.

PART 3 - EXECUTION

3.1 INSTALLATION

- A. Furnish and install all surface metal raceways parallel and perpendicular to the structure.

- B. Furnish and install each surface metal raceway installation complete with all appropriate fittings.
- C. All cuts shall be made with appropriate cutting tools manufactured by the manufacturer of the raceway. Coat all field cut exposed edges to prevent corrosion.
- D. The use of small scrap lengths of raceway to comprise an installation is prohibited. Raceway shall be installed such that in any continuous installation of under 30 feet length, a maximum of three sections may be joined providing that not less than one section is a full ten feet in length except as specifically permitted by the Architect or Owner's representative.
- E. Do not use surface metal raceway in place of flush mounted device boxes with concealed conduit, except in locations specifically indicated, or where approved in writing by the Engineer.
- F. Runs passing through walls or ceilings: Where two piece raceway installations pass through walls or ceilings, cut the cover on both sides of the wall or ceiling to permit the removal of the cover on each side of the obstruction.
- G. Do not install surface metal raceway concealed in walls or ceilings, except where it passes through walls.
- H. Wiring: Conductors shall be extended to branch circuit panel as shown on the drawings.
- I. Grounding: Provide one #12 green grounding conductor in all two piece metal raceways bonded to base and receptacles.

END OF SECTION 260524

SECTION 260553 - ELECTRICAL IDENTIFICATION

PART 1 - GENERAL

1.1 RELATED DOCUMENTS

- A. Drawings and general provisions of the Contract, including General and Supplementary Conditions and Division 1 Specification Sections, apply to this Section.

1.2 SUMMARY

- A. This Section includes the following:
 - 1. Identification for raceways.
 - 2. Identification for conductors and communication and control cable.
 - 3. Instruction signs.
 - 4. Equipment identification labels and nameplates.
 - 5. Panelboard directories.
 - 6. Miscellaneous identification products.

1.3 SUBMITTALS

- A. Product Data: For each electrical identification product indicated.

1.4 QUALITY ASSURANCE

- A. Comply with ANSI A13.1 and ANSI C2.
- B. Comply with NFPA 70.
- C. Comply with 29 CFR 1910.145.

1.5 COORDINATION

- A. Coordinate identification names, abbreviations, colors, and other features with requirements in the Contract Documents, Shop Drawings, manufacturer's wiring diagrams, and the Operation and Maintenance Manual, and with those required by codes, standards, and 29 CFR 1910.145. Use consistent designations throughout Project.
- B. Coordinate installation of identifying devices with completion of covering and painting of surfaces where devices are to be applied.
- C. Coordinate installation of identifying devices with location of access panels and doors.
- D. Install identifying devices before installing acoustical ceilings and similar concealment.

PART 2 - PRODUCTS

2.1 RACEWAY IDENTIFICATION MATERIALS

- A. Comply with the specific requirements of other sections of these Specifications.

2.2 CONDUCTOR AND COMMUNICATION- AND CONTROL-CABLE IDENTIFICATION MATERIALS

- A. Marker Tapes: Vinyl-cloth, self-adhesive wraparound type, with circuit identification legend machine printed, equal to Thomas and Betts #WBC Series, or approved equal.

2.3 INSTRUCTION SIGNS

- A. Engraved, laminated acrylic or melamine plastic, minimum 1/16 inch (1.6 mm) thick for signs up to 20 sq. in. (129 sq. cm) and 1/8 inch (3.2 mm) thick for larger sizes.
 - 1. Engraved legend with black letters on white face.
 - 2. Punched or drilled for mechanical fasteners.
 - 3. Framed with mitered acrylic molding and arranged for attachment at applicable equipment.

2.4 EQUIPMENT IDENTIFICATION LABELS AND NAMEPLATES

- A. Engraved, Laminated Acrylic or Melamine Label: Punched or drilled for screw mounting. White letters on a dark-gray background. Minimum letter height shall be 3/8 inch (10 mm) where not specifically indicated otherwise in this Section.

2.5 MISCELLANEOUS IDENTIFICATION PRODUCTS

- A. Cable Ties: Fungus-inert, self-extinguishing, 1-piece, self-locking, Type 6/6 nylon cable ties.
 - 1. Minimum Width: 3/16 inch (5 mm).
 - 2. Tensile Strength: 50 lb (22.6 kg), minimum.
 - 3. Temperature Range: Minus 40 to plus 185 deg F (Minus 40 to plus 85 deg C).
 - 4. Color: Black, except where used for color-coding.
- B. Fasteners for Labels and Signs: Self-tapping, stainless-steel screws or stainless-steel machine screws with nuts and flat and lock washers.

PART 3 - EXECUTION

3.1 APPLICATION

- A. Accessible Raceways of Auxiliary Systems: Identify the following systems as directed elsewhere in these Specifications:

1. Fire Alarm System.
 2. Control Wiring.
- B. Device and Junction Box Identification:
1. In finished rooms: Provide a pressure sensitive, adhesive film label on the exterior of each wiring device or junction box cover plate, indicate the panelboard and circuit number of each circuit serving the box.
 - a. Mark receptacle cover plate with a clear label with black lettering indicating panel and circuit; Example: "Panel PR2-B4, Cir. #3".
 - b. Mark switch cover plate with a clear label with black lettering indicating panel and circuit; Example: "Panel PL3-A2, Cir. #13".
 2. In non-finished rooms and junction boxes above ceilings: Provide on the exterior of each junction box coverplate, indicate the panelboard and circuit number of each circuit serving the box with permanent marker (Black, Blue or Red) for above ceilings only.
- C. Pull and Junction Boxes, Feeder Bus Taps:
1. Identify by stenciling on the boxes, system use, etc., as directed by the Owner's Representative.
 2. Covers for pull and junction boxes shall be marked with felt tip pen, crayon, or other approved permanent marking means, indicating system type (i.e. lighting, power, emergency, etc.), panel and circuit number, if applicable destination, etc. (e.g. EM RM. #213, Panel E-1, Cir. #1,3,5).
- D. Branch-Circuit Conductor Identification: Use marker tape. Identify each ungrounded conductor according to source and circuit number.
- E. Conductors to Be Extended in the Future: Attach marker tape to conductors and list source and circuit number.
- F. Auxiliary Electrical Systems Conductor Identification: Identify field-installed alarm, control, signal, sound, and intercommunications connections.
1. Identify conductors, cables, and terminals in enclosures and at junctions, terminals, and pull points. Identify by system and circuit designation.
 2. Use system of marker tape designations that is uniform and consistent with system used by manufacturer for factory-installed connections.
 3. Coordinate identification with Project Drawings, manufacturer's wiring diagrams, and Operation and Maintenance Manual.
- G. Instruction Signs:
1. Operating Instructions: Install instruction signs to facilitate proper operation and maintenance of electrical systems and items to which they connect. Install instruction signs with approved legend where instructions are needed for system or equipment operation.
- H. Equipment Identification Labels: On each unit of equipment, install unique designation label that is consistent with wiring diagrams, schedules, and Operation and Maintenance Manual. Apply labels to disconnect switches and protection equipment, central or master units, control

panels, control stations, terminal cabinets, and racks of each system. Systems include power, lighting, control, communication, signal, monitoring, and alarm systems unless equipment is provided with its own identification.

1. Labeling Instructions:
 - a. Indoor Equipment: Engraved, laminated acrylic or melamine label. Unless otherwise indicated, provide a single line of text with 1/2-inch- (13-mm-) high letters on 1-1/2-inch- (38-mm-) high label; where 2 lines of text are required, use labels 2 inches (50 mm) high.
 - b. Elevated Components: Increase sizes of labels and letters to those appropriate for viewing from the floor.
2. Equipment to Be Labeled:
 - a. Disconnect Switches, Branch Switches, Starters, Etc.:
 - 1) Provide an engraved laminated acrylic or melamine label with 3/16" high letters, securely attached to the exterior of the device.
 - 2) Label shall include the name of the load it serves and the source of power; Example: "ACP-20 fed from MCC-20, Cubicle 5A located in Room #B64".

3.2 INSTALLATION

- A. Verify identity of each item before installing identification products.
- B. Location: Install identification materials and devices at locations for most convenient viewing without interference with operation and maintenance of equipment.
- C. Apply identification devices to surfaces that require finish after completing finish work.
- D. Self-Adhesive Identification Products: Clean surfaces before application, using materials and methods recommended by manufacturer of identification device.
- E. Attach nonadhesive signs and plastic labels with screws and auxiliary hardware appropriate to the location and substrate.
- F. Color-Coding for Conductor Identification, 600 V and Less:
 1. Color shall be factory applied to the full length of the insulation.
 2. Colors for 208Y/120V 3Ph 4W Circuits:
 - a. Phase A: Black.
 - b. Phase B: Red.
 - c. Phase C: Blue.
 - d. Neutral – Phase A: White with Black colored stripe.
 - e. Neutral – Phase B: White with Red colored stripe.
 - f. Neutral – Phase C: White with Blue colored stripe.
 - g. Shared Neutral: White with no tracer.
 - h. Ground: Green.
 - i. Switch Travelers: Orange.
 - j. Switch Return: Yellow.

3. Colors for 480Y/277V 3Ph 4W Circuits:

- a. Phase A: Brown.
- b. Phase B: Orange.
- c. Phase C: Yellow.
- d. Neutral – Phase A: Gray with Brown colored stripe.
- e. Neutral – Phase B: Gray with Orange colored stripe.
- f. Neutral – Phase A: Gray with Yellow colored stripe.
- g. Shared Neutral: Gray with no tracer.
- h. Ground: Green.
- i. Switch Travelers: Orange.
- j. Switch Return: Yellow.

- G. All transformers, secondary switchgear, feeders, bus ducts, power sub-feeds to motors, etc., shall be completely phased out as to sequence and rotation and so labeled.
- H. Phase sequence shall be N-A-B-C, proceeding in direction of left to right, front to back, top to bottom. All phases and neutral shall be identified with 1" Brady wrap-on wire markers.
- I. Identify conductors of different systems at each junction box; pull box, and termination with tags as approved by the Owner's Representative.
- J. Where two or more neutrals are included in the same conduit, at each panel, junction box, etc., the proper neutral wire shall be permanently and effectively identified with its branch circuit conductor(s) taped together and labeled with circuit number(s).

3.3 PANELBOARD DIRECTORIES

- A. Directories: The contractor shall provide a completed protected typewritten panelboard directory card in each panelboard. The directory shall be approximately 5"x8" and shall indicate load designations with the Owner's associated room numbers for each circuit.

END OF SECTION 260553

SECTION 260933 – ARCHITECTURAL LIGHTING CONTROL SYSTEMS

PART 1 - GENERAL

1.1 RELATED DOCUMENTS

- A. Drawings and general provisions of the Contract, including General and Supplementary Conditions and Division 1 Specification Sections, apply to this Section.

1.2 DEFINITIONS

- A. The term “Manufacturer” or “Lighting Control Equipment Manufacturer” as used herein shall be defined as the manufacturer responsible for fabrication, assembly, and shipping of all laboratory lighting control system equipment as covered in these specifications and related drawings.
- B. The term “Lighting Control Equipment Supplier” shall be defined as the manufacturer’s factory authorized sales agency and/or factory authorized service center.
- C. The term Owner as used herein shall refer to the organization(s), individuals and their representatives as typically defined.
- D. Technical terms pertinent to architectural type lighting control equipment, dimming equipment and related work shall be construed in the following order, in accordance with:
 - 1. Notes and details on drawings.
 - 2. General recognized industry usage.
 - 3. Relevant usage and definitions of handbooks, guidebooks, or trade group recommendations by manufacturer’s associations or professional and engineering societies including but not limited to the following:
 - a. Underwriters Laboratories (UL).
 - b. Illuminating Engineering Society of North America (IESNA).
 - c. National Fire Protection Association (NFPA).
 - d. National Electrical Code (NEC).
 - e. National Electrical Manufacturer’s Association (NEMA).

1.3 SUMMARY

- A. The work required under this Section consists of providing all room controllers, digital occupancy sensors, digital button stations, cables, accessories, commissioning and demonstration for a complete lighting control system.
- B. Related Sections include the following:
 - 1. Division 26 Section “Lighting Equipment”.

1.4 SYSTEM DESCRIPTION & OPERATION

A. The Lighting Control and Automation system as defined under this section covers the following equipment:

1. Digital Room Controllers – Self-configuring, digitally addressable one, two or three relays controllers with 0-10 volt control for ballasts (if applicable) and single relay application-specific plug load controllers.
2. Digital Occupancy Sensors – Self-configuring, digitally addressable and calibrated occupancy sensors with LCD display and two-way active infrared (IR) communications.
3. Digital Switches – Self-configuring, digitally addressable pushbutton switches, dimmers, and scene switches with two-way active infrared (IR) communications.
4. Configuration Tools – Handheld remote for room configuration provides two way infrared (IR) communications to digital devices and allows complete configuration and reconfiguration of the device / room from up to 30 feet away. Unit to have Organic LED display, simple pushbutton interface, and allow send and receive of room variables and store of occupancy sensor settings. Computer software also customizes room settings.
5. Handheld remotes for personal control – One-button dimming, two-button on/off, or five-button scene remotes provide control using infrared communications. Remote may be configured in the field to control selected loads or scenes without special tools.
6. Digital Lighting Management (DLM) local network – Free topology, plug-in wiring system (Cat 5e) for power and data to room devices.

1.5 SUBMITTALS

A. Submit in accordance with Division 1 requirements.

B. Product Data: Provide manufacturer's data for products and materials as indicated.

C. Submit complete bound and organized Architectural Lighting Control System submittals. All information to be submitted shall be manufacturer's original printed material; submittals consisting of photocopied materials will not be acceptable. Each submittal package shall contain the following:

1. Product Data and Installation Instructions: For each component.
2. Shop Drawings:
 - a. System riser diagrams.
 - b. Device wiring diagrams.
 - c. Device termination diagrams.
 - d. Details showing interconnections with other systems if applicable.

D. Submit drawings prepared by competent draftsmen specifically for this project, generic drawings will not be accepted. Provide the following:

1. Separate floor plans showing manufacturer's recommended location for each occupancy sensor. Drawings shall indicate manufacturer's model numbers for each device and shall be keyed to related wiring diagrams.
2. Separate system wiring diagrams for each and every system showing each major item of equipment and connections.
3. Separate 1/8" = 1' scale floor plans keyed to the system riser diagrams for each and every system to be provided showing all equipment locations, recommended sensor placement, conduit routing and sizes, quantity and types of cables.

- E. Product Certificates: Signed by manufacturers of equipment certifying that products furnished comply with specified requirements.
- F. Guarantees: The system manufacturer shall furnish a certificate for all guarantees required under subsequent requirements of this section.

1.6 PRODUCT SAMPLES

- A. The Engineer reserves the right to request an engineering sample product of each and every room controller, digital occupancy sensor, digital button station and/or accessory for inspection. Samples submitted shall be in full compliance with the specifications.

1.7 OPERATIONAL AND MAINTENANCE DATA

- A. At completion of the project, the Electrical Contractor shall submit complete bound and organized operational and maintenance data packages. All information to be submitted shall be manufacturer's original printed material; submittals consisting of photocopied materials will not be acceptable. Each package shall contain the following:
 - 1. Detailed product data, installation and maintenance instructions for each system component and accessory to be provided.
 - 2. A catalog cut sheet for each and every system component and accessory.
 - 3. System riser diagrams.
 - 4. Device wiring diagrams.
 - 5. Device termination diagrams.
 - 6. Details showing interconnections with other systems if applicable.
 - 7. Print-out and electronic copy of final system management and configuration from enterprise software. Programming documentation to be unlocked so that Purdue can access, view and modify using enterprise software provided.

1.8 STANDARDS AND QUALITY ASSURANCE

- A. All Equipment and Work shall comply with applicable NFPA 70, National Electrical Code (NEC) requirements.
- B. All equipment shall comply with applicable National Electrical Manufacturers Association (NEMA) and American National Standards Institute (ANSI) standards.
- C. All equipment shall be Underwriters Laboratories (U.L.) listed and labeled. Proof of listing shall be provided.
 - 1. UL 916 – Energy Management Equipment.
 - 2. UL 924 – Emergency Lighting
- D. System risers, schedules, conduit and wiring shown on drawings are for estimating purposes only. All items of minor equipment required for a complete and operating installation shall be provided even if not specifically mentioned in these specifications. No claim or extra charge will be accepted for any variation from data shown on drawings or descriptions in specifications.

- E. Source Limitations: A single manufacturer shall provide all occupancy sensors and accessories. It shall be the responsibility of the manufacturer to provide all components required for compatibility of the equipment specified in this Section with other products specified in other sections of this specification.
- F. Performance Testing Requirements: All equipment shall be 100% tested. Sample testing is not acceptable.
- G. Manufacturer Qualifications and Requirements:
 - 1. Experience: The manufacturer shall have been continuously engaged in the manufacture of commercial lighting controls and occupancy sensors for no less than five years.
 - 2. ISO Certification: The Manufacturer shall be ISO-9001 certified.
 - 3. Professional Affiliations: The manufacturer shall be an active member of the following related professional organizations:
 - a. Lighting Controls Association (LCA).
 - b. Illuminating Engineering Society of North America (IESNA).
 - 4. Support:
 - a. The manufacturer shall maintain a web based technical service site, an 800 technical service telephone number and a staff of factory direct service representatives that are capable of responding to a service request within eight hours of notification.
 - b. The manufacturer shall maintain a factory authorized service center within 100 miles of the project site staffed by factory trained and authorized service technicians.
 - c. The manufacturer shall manufacture programming software package(s) specifically produced for the lighting control equipment to be furnished under this section.
 - 5. Testing: The manufacturer shall perform 100 percent functional testing of all components to confirm proper operation prior to shipment; sample testing will not be acceptable.
 - 6. The manufacturer shall maintain a web site to make bulletins, complete manuals, and application assistance available. The website shall offer online technical support and troubleshooting assistance.
- H. Lighting Control Equipment Supplier Qualifications and Requirements:
 - 1. The Lighting Control Equipment Supplier shall be a factory authorized representative agency and/or factory authorized service center for the lighting control, networking and dimming equipment to be furnished under this section.
 - 2. The Lighting Control Equipment Supplier shall maintain a staff of qualified engineering specialists for the design and engineering assistance of the lighting control, networking, and dimming equipment to be furnished under this section.
 - 3. The Lighting Control Equipment Supplier shall be factory trained in the application, installation, programming and adjustment of the equipment to be furnished under this section.

1.9 STORAGE AND PROTECTION

- A. Storage and Protection: The Electrical Contractor shall be responsible for providing proper storage, protection and handling of all equipment until it is installed, connected and placed into

operation. Materials shall be stored in a secure location away from exposure to construction and weather. The equipment shall be stored at a location with the temperature and humidity requirements as recommended by the manufacturer.

1.10 "AS-BUILT" DRAWINGS AND OPERATIONAL AND MAINTENANCE DATA

- A. Documentation: Provide two (2) complete of "As-Built" drawings with two (2) complete copies of the Operation and Maintenance manuals.

1.11 WARRANTY

- A. All equipment furnished under this Section shall be warranted to be free from defects in material or workmanship.
- B. Manufacturer's Special Warranties:
 - 1. All Equipment: Written warranty, executed by the manufacturer agreeing to replace all equipment that fails due to defects in manufacturer's materials or workmanship for a period of five (5) years from the date of commissioning.
 - 2. Submit printed Warranty document from manufacturer clearly stating five year Warranty on complete system. Separate documentation on individual product data sheets are not an acceptable substitute for single printed Warranty document.

1.12 MANUFACTURERS

- A. Design Basis Manufacturer: The lighting control equipment specified in this section is the "Digital Lighting Management System" manufactured by Wattstopper/Legrand and shall serve to indicate the level of quality and minimum requirements for the lighting control equipment to be furnished for this project.
 - 1. Where devices and material are mentioned by name and/or model number, it shall be interpreted as referring to that particular item as completely specified in the manufacturer's published data as though that data and literature were printed herein in their entirety.
- B. Acceptable Manufacturers: Where acceptable manufacturers are listed, this shall be interpreted to mean that products by the listed manufacturers will be acceptable as equals to the "Design Basis Manufacturer" products provided that the manufacturer demonstrates full compliance with all of the requirements contained in these specifications. Lighting control equipment by the following manufacturers will be acceptable subject to full compliance with the requirements of the specifications:
 - 1. Cooper Greengate.
 - 2. Acuity Controls.
 - 3. Other manufacturers as pre-approved by the Engineer and added by written addendum.
- C. Pre-Approval: Submittals for pre-approval by the Engineer shall be made in accordance with the following:
 - 1. Pre-approval packages must be submitted prior to issuance of the final addendum.

2. All manufacturer requirements must be in full compliance with all of the provisions contained in this specification section. Detailed information shall be provided to demonstrate full compliance including all certifications and references for review and approval by the Engineer.
3. All equipment must be in full compliance with all of the provisions contained in this specification section. Detailed technical information including but not limited to a complete Bill of Material, catalog data sheets, a system riser diagram, and a line by line comparison with the specifications shall be provided for the Engineer's use in determining compliance with the specifications.
4. All exceptions with the requirements of the Contract Documents shall be brought to the attention of the Engineer in writing. Means to provide technical compensation for those exceptions shall be fully detailed in writing for review and approval by the Engineer.
5. The Engineer shall reserve the right to request an engineering sample product of each and every item of equipment for inspection. Samples submitted shall be in full compliance with the specifications including but not limited to construction, design, visual appearance, and performance. The manufacturer shall have previously built the item of equipment and the item shall be a production item.
6. Supporting data shall be furnished with the submittal that shall include a list of representative installations similar in function and scope to that specified. Such listing shall include the names, addresses and telephone numbers of persons associated with the operation and knowledgeable about the referenced installations.

PART 2 - PRODUCTS

2.1 CEILING MOUNTED OCCUPANCY SENSOR SYSTEM

- A. Ceiling mounted dual technology (passive infrared and ultrasonic) occupancy sensor. Sensors shall be connected over either lighting control system digital lighting management network, or dedicated hardwired connection to a room controller and shall be assignable to control any room control relay on the lighting control network.
- B. Digital Control Option (Design Basis):
 1. Digital Occupancy Sensors shall provide graphic LCD display for digital calibration and electronic documentation. Features include the following:
 2. Digital calibration and pushbutton programming for the following variables:
 - a. Sensitivity – 0-100% in 10% increments
 - b. Time delay – 1-30 minutes in 1 minute increments
 - c. Test mode – Five second time delay
 - d. Detection technology – PIR, Ultrasonic or Dual Technology activation and/or re-activation.
 - e. Walk-through mode
 - f. Load parameters including Auto/Manual-ON, blink warning, and daylight enable/disable when photosensors are included in the DLM local network.
 3. One (1) or two (2) RJ-45 port(s) for connection to the lighting control local network.
 4. Two-way infrared (IR) transceiver to allow remote programming through handheld commissioning tool and control by remote personal controls.
 5. Device Status LEDs including:

- a. PIR Detection
 - b. Ultrasonic detection
 - c. Configuration mode
 - d. Load binding
6. Assignment of occupancy sensor to a specific load within the room without wiring or special tools.
 7. Manual override of controlled loads.
 8. Units shall not have any dip switches or potentiometers for field settings.
 9. Multiple occupancy sensors shall be capable of being installed in a room by connecting them to lighting control local network. No additional configuration will be required.
 10. Acceptable Products:
 - a. Dual-Technology Sensor: Wattstopper #LMDC-100 Series.
- C. Hardwired Control Option:
1. Occupancy Sensors shall provide the following features:
 2. Pushbutton programming for the following variables:
 - a. PIR Sensitivity – 50% or 100%.
 - b. Time delay – 5-30 minutes in 5 minute increments.
 - c. Test mode – Five second time delay.
 - d. Detection technology – PIR, Ultrasonic or Dual Technology activation and/or re-activation.
 - e. Walk-through mode.
 - f. Load parameters including Auto/Manual-ON and sweep mode.
 3. Two (2) sets of terminals for connection to the lighting control room controllers.
 4. Device Status LEDs including:
 - a. PIR Detection
 - b. Ultrasonic detection
 5. Assignment of occupancy sensor to a specific load within the room without wiring or special tools.
 6. Manual override of controlled loads.
 7. Multiple occupancy sensors shall be capable of being installed in a room by connecting them to lighting control local network.
 8. Acceptable Products:
 - a. Dual-Technology Sensor: Cooper Controls Greengate #OAC-DT-1000 Series.

2.2 DIGITAL WALL SWITCHES

- A. Low voltage momentary pushbutton switches in 1, 2, 3, 4, 5 and 8 button configuration as indicated on the drawings with compatible with wall plates with decorator opening. Wall switches shall include the following features:
1. Two-way infrared (IR) transceiver for use with personal and configuration remote controls.

2. Removable buttons for field replacement with engraved buttons and/or alternate color buttons. Button replacement may be completed without removing the switch from the wall.
 3. Red configuration LED on each switch that blinks to indicate data transmission.
 4. Blue Load/Scene Status LED on each switch button with the following characteristics:
 - a. Bi-level LED
 - b. Dim locator level indicates power to switch
 - c. Bright status level indicates that load or scene is active
 5. Dimming switches shall include seven bi-level LEDs to indicate load levels using 14 steps.
- B. Two RJ-45 ports for connection to the lighting control local network.
- C. Multiple digital wall switches shall be capable of being installed in a room by connecting them to the lighting control local network. No additional configuration will be required to achieve multi-way switching.
- D. The following switch attributes may be changed or selected using a wireless configuration tool:
1. Load and Scene button function may be reconfigured for individual buttons (from Load to Scene, and vice versa).
 2. Individual button function may be configured to Toggle, On only or Off only.
 3. Individual scenes may be locked to prevent unauthorized change.
 4. Fade Up and Fade Down times for individual scenes may be adjusted from 0 seconds to 18 hours.
 5. Ramp rate may be adjusted for each dimmer switch.
 6. Switch buttons may be bound to any load on a room controller and are not load type dependant; each button may be bound to multiple loads.
- E. Color: The color for each digital wall station shall be as selected by the Architect from the Manufacturer's standard colors. The manufacturer shall have a minimum color selection from: white, light almond, ivory, grey and black.
- F. Engraving and Labels: Digital wall stations shall be furnished with engraving and/or labels on the stations and buttons as indicated on the drawings or as selected by the Architect/Engineer.
- G. Acceptable Products:
1. One Button Station: Wattstopper #LMSW-101, Cooper Greengate #GDS-1TLB.
 2. Two Button Station: Wattstopper #LMSW-102, Cooper Greengate #GDS-2TLB.
 3. Three Button Station: Wattstopper #LMSW-103, Cooper Greengate #GDS-3TLB.
 4. Four Button Station: Wattstopper #LMSW-104, Cooper Greengate #GDS-4TSB.
 5. Eight Button Station: Wattstopper #LMSW-108, Cooper Greengate two (2) #GDS-4TSB.
 6. Dimming Wall Station: Wattstopper #LMDM-101, Cooper Greengate #GDS-2TLB.
 7. Dimming Five Button Scene Station: Wattstopper #LMSW-105.

2.3 ROOM CONTROLLERS

- A. Room Controllers shall automatically bind the room loads to the connected devices in the space without commissioning or the use of any tools. Room Controllers shall be provided to match the

room lighting load and control requirements as indicated on the drawings. The controllers shall not have, dip switches, potentiometers or require special configuration. The control units shall include the following features:

1. Automatic room configuration to the most energy-efficient sequence of operation based upon the devices in the room.
2. Simple replacement – Using the default automatic configuration capabilities, a room controller may be replaced with an off-the-shelf unit without requiring any configuration or setup.
3. Device Status LEDs to indicate:
 - a. Data transmission
 - b. Device has power
 - c. Status for each load
 - d. Configuration status
4. Quick installation features including:
 - a. Standard junction box mounting
 - b. Quick low voltage connections using standard RJ-45 patch cable
5. Plenum rated enclosure.
6. Manual override and LED indication for each load
7. Dual voltage (120/277 VAC, 60 Hz) load control capability.
8. Zero cross circuitry for each load.

B. On/Off Room Controllers shall include:

1. One (1) or two (2) relay configuration as indicated on the drawings.
2. 150 mA switching power supply.
3. Three (3) RJ-45 local network ports.
4. Discrete model listed for connection to receptacles, for occupancy-based control of plug loads within the space.
 - a. One relay configuration only.
 - b. Automatic-ON/OFF configuration.
5. Acceptable Products:
 - a. One Relay: Wattstopper #LMRC-101, Cooper Greengate #CK2-120NO.
 - b. Two Relay: Wattstopper #LMRC-102, Cooper Greengate #CK2-120NO.

C. On/Off/Dimming enhanced Room Controllers shall include:

1. Real time current monitoring
2. One (1), two (2) or three (3) relay configuration.
3. 250 mA switching power supply.
4. Four (4) RJ-45 local network ports.
5. One (1) 0-10 volt analog output per relay for control of compatible ballasts and LED drivers.
6. Optional Network Bridge for BACnet MS/TP communications.
7. The following dimming attributes may be changed or selected using a wireless configuration tool:

- a. Establish preset level for each load from 0-100%
 - b. Set high and low trim for each load
 - c. Set lamp burn in time for each load up to 100 hours
8. Discrete model listed for connection to receptacles, for occupancy-based control of plug loads within the space.
 - a. One relay configuration only.
 - b. Automatic-ON/OFF configuration.
9. Acceptable Products:
 - a. One Relay, 0-10V Dimming: Wattstopper #LMRC-211, Cooper Greengate #CK4A.
 - b. Two Relay, 0-10V Dimming: Wattstopper #LMRC-212, Cooper Greengate #CK4A.
 - c. Three Relay, 0-10V Dimming: Wattstopper #LMRC-213, Cooper Greengate #CK4A.
 - d. One Relay, 0-10V Dimming with Network Bridge: Wattstopper #LMRC-311.
 - e. Two Relay, 0-10V Dimming with Network Bridge: Wattstopper #LMRC-312.
 - f. Three Relay, 0-10V Dimming with Network Bridge: Wattstopper #LMRC-313.
- D. Isolated Relay Interface for Building Automation System (Design Basis):
 1. Real time current monitoring
 2. One (1) Single-Pole-Double-Throw (SPDT) configuration. Contacts rated for 1A 24VDC.
 3. Contacts for building management system wiring to relay.
 4. 7 mA switching power supply.
 5. Two (2) RJ-45 local network ports.
 6. The relay shall close when any occupancy sensor on the network indicated occupied state.
 7. Acceptable Products:
 - a. Isolated Relay: Wattstopper #LMRL-100.
 - b. Optional Design for Interface for Building Automation System: Provide additional SPDT relay contact on lighting controller for building energy management system. See Lighting Control Wiring Diagrams.

2.4 LIGHTING CONTROL NETWORK

- A. The lighting control local network shall be a free topology lighting control physical connection and communication protocol designed to control a small area of a building. Digital room devices shall connect to the network via CAT 5e rated cables with RJ-45 connectors that shall provide both data and power to room devices.
- B. Features of the local network:
 1. Simple replacement of any device in the network with a standard off the shelf unit without requiring commissioning, configuration or setup.
 2. Other features and functions shall be as required under one of the following options:
- C. Features of the local network "Plug n' Go" Option" (Design Basis):

1. "Plug n' Go" automatic configuration and binding of occupancy sensors, switches and lighting loads to the most energy-efficient sequence of operation based upon the device attached.
2. "Push n' Learn" configuration to change the automatic configuration, including binding and load parameters without tools, using only the buttons on the digital devices in the local network.
3. Two-way infrared communications for control by handheld remotes, and configuration by a handheld tool including adjusting load parameters, sensor configuration and binding, within a line of sight of up to 30 feet from a sensor, wall switch or IR receiver.

D. Features of the local network "Software" Option (Optional):

1. Enterprise level software to program function and operation of all networked room controllers and associated button controls, occupancy sensors, dimmers and relays.
2. Programed lighting control configuration shall be savable on computer or storage media.
3. Lighting control configurations shall be creatable and editable using the Enterprise level software either on-line, or off-line.
4. Enterprise level software shall allow for real-time monitoring and control of the lighting relays.

E. Standard Control Cables: Control network cables shall be furnished by the system manufacturer and shall:

1. Be Category 5e rated minimum consisting of four unshielded twisted copper pairs with overall green outer jacket with colored stripe.
2. Be non-plenum rated and installed in a closed conduit system as indicated on the drawings.
3. Be pre-terminated with RJ-45 connectors.
4. Be furnished in lengths as required to connect all lighting control system equipment.
5. Be furnished complete with all splitters, couplers, and accessories as required.
6. Acceptable Products: Wattstopper #LMRJ Series, or as recommended by Cooper Controls for the Greengate system.

F. Control Cables for Use in Raceways Containing Power: Control network cables shall have UL listed 600V overall jacket and shall:

1. Be Category 5e rated minimum consisting of four unshielded twisted copper pairs with overall 600V rated jacket.
2. Be non-plenum rated and installed in a closed conduit system as indicated on the drawings.
3. Be pre-terminated with RJ-45 connectors.
4. Be furnished in lengths as required to connect all lighting control system equipment.
5. Be furnished complete with all splitters, couplers, and accessories as required.
6. Acceptable Products: Belden DataTuff #E505005 (5 meter), #E505010 (10 meter), or approved equal.

2.5 CONFIGURATIONS TOOLS

- A. The configuration tool shall be provided for custom programming and configuration of lighting control local networks.
- B. Computer Interface: Interface designed to connect laptop computer through USB port, or through Ethernet port to the digital lighting management network. Acceptable Products:

Wattstopper #LMCI-100 Digital Computer to DLM Interface, Cooper #Greengate Ethernet Interface Module (EIM).

C. Enterprise Software Option:

1. Software for on-line and off-line creation and editing of lighting control, control assignments, zones and relay and dimmer responses.
2. Software shall run on Microsoft Windows 7.
3. Provide one (1) fully licensed and operational software package for installation on computer furnished by Purdue. Licensing shall be full and complete and shall not require annual renewal.
4. Acceptable Products: Wattstopper #LMCI-100 Digital Lighting Management (DLM), Software, Cooper #Greengate Enterprise Software.

PART 3 - EXECUTION

3.1 INSTALLATION

- A. The electrical contractor shall install all equipment per specifications and in full compliance with the manufacturer's instructions. The system shall be initially energized when authorized by and in the presence of the manufacturer and/or manufacturer's Lighting Control Equipment Supplier.
- B. All occupancy sensors shall be installed in locations as directed and verified by the manufacturer for optimum coverage and performance for the type of sensor to be provided in the respective space. All sensors requiring aiming shall be aimed as directed by the manufacturer.
- C. All wiring and control cable shall be installed in metal conduit or surface raceway.
- D. Where control cabling is installed in raceway with power wiring, it shall have 600V listed jacket.

3.2 RESPONSIBILITY OF THE CONTRACTOR

A. The Contractor shall:

1. Protect products and equipment from damage during all phases of construction including storage, preparation, testing and cleanup.
2. Furnish and install all properly sized conduits, outlet boxes, junction boxes, terminal cabinets, etc., sized as required for installation of all lighting control equipment.
3. Furnish and install all control, electrical power and grounding conductors and all connectors as required and as shown on the drawings.
4. Completely test for continuity and shorts each and every high and low voltage conductor that comprises the lighting control system.
5. Receive, unload, and provide secure storage for materials delivered to the project by the manufacturer and be responsible for materials whether installed or not until accepted by the Owner.
6. Install all lighting control equipment in accordance with the manufacturer's directions.
7. Make all final connection to all equipment as shown on the manufacturer's drawings and as directed.
8. Coordinate complete installation of all lighting controls systems with the Lighting Control Equipment Supplier and Manufacturer including installation of all equipment, enclosures, conduits, and wiring.

9. Notify the Lighting Control Equipment Supplier and Manufacturer that the system is ready for commissioning and testing. Notification shall be provided a minimum of ten (10) days prior to the date for testing. Power shall not be applied to the system prior to testing except as permitted in writing by the Manufacturer and/or Manufacturer's Lighting Control Equipment Supplier.

3.3 RESPONSIBILITY OF THE LIGHTING CONTROL EQUIPMENT SUPPLIER

A. The Lighting Control Equipment Supplier shall:

1. Be responsible for coordination with the manufacturer for the design of a complete and operating system and shall provide all components necessary for proper operation of each system even if component is not specifically listed in these Specifications.
2. Coordinate complete installation of all lighting controls systems with the Manufacturer and Contractor including installation of all equipment, enclosures, conduits, and wiring.
3. Be available as a technical reference for the Contractor to respond to any questions relating to the installation and/or adjustment of lighting control equipment.
4. Provide all initial programming for each lighting controls system per the Owner and/or Architect/Engineer's written directions or as shown and scheduled on the Contract Documents.
5. Provide engineers and/or technicians fully experienced in the programming requirements.
6. Demonstrate the system in the presence of the Owner as directed, proving it to be operating properly and shall provide instructions in the use and in the Owner performed maintenance of the system.
7. Provide instruction in system operation and maintenance; a minimum four hour period separate from the demonstration and offered at the convenience of the Owner's schedule.

3.4 TESTING AND DEMONSTRATION

- A. Testing: The Electrical Contractor in conjunction with the Manufacturer and Lighting Control Equipment Supplier shall test each and every item of equipment prior to demonstration and shall provide a signed report to the Owner certifying proper operation of each item of equipment. Testing shall be performed after installation of all equipment, wiring, and connections are complete and after all lamps have been installed in lighting fixtures.
- B. Standard factory test of manufacturer shall be performed and typewritten copies submitted to the owner for record purposes.
- C. Provide for final adjustments for systems.
- D. Demonstration: The Contractor and Manufacturer shall provide a demonstration of all lighting control equipment to the Owner's Representative and Owner's personnel.

3.5 INSTRUCTION

- A. The Electrical Contractor shall provide instruction to the Owner's personnel in the adjustment, care, maintenance and operation of each item of equipment.

3.6 ADJUSTING

- A. Occupancy Adjustments: When requested within 12 months from the Date of Substantial Completion, provide on-site assistance in adjusting occupancy sensors and controls to suit actual occupied conditions. Provide up to two visits to the project site during other-than-normal occupancy hours for this purpose.

END OF SECTION 260933

SECTION 262101 – CONDUCTORS AND CABLES

PART 1 - GENERAL

1.1 RELATED DOCUMENTS

- A. Drawings and general provisions of the Contract, including General and Supplementary Conditions and Division 1 Specification Sections, apply to this Section.
- B. Related Sections include the following:
 - 1. Division 7 Section "Firestopping."
 - 2. Division 26 Section "Basic Electrical Requirements."
 - 3. Division 26 Section "Grounding and Bonding for Electrical Systems."
 - 4. Division 26 Section "Electrical Identification."

1.2 SUMMARY

- A. This Section includes building wires and cables and associated connectors, splices, and terminations for wiring systems rated 600 V and less.

1.3 DEFINITIONS

- A. Isolated circuit: A branch circuit installed separately from all other wiring in a separated conduit.
- B. Dedicated circuit: A branch circuit installed specifically for a single particular appliance or outlet. Conductors may be installed in a common conduit with wiring serving other devices.

1.4 SUBMITTALS

- A. Product Data: Provide submittal for all conductor and cables indicating compliance with this section.

1.5 QUALITY ASSURANCE

- A. Listing and Labeling: Provide wires and cables specified in this Section that are listed and labeled.
 - 1. The Terms "Listed" and "Labeled": As defined in NFPA 70, Article 100.
- B. Comply with NFPA 70.
- C. All wire shall be new; the use of salvaged conductors is expressly prohibited.

1.6 DELIVERY, STORAGE, AND HANDLING

- A. Deliver wires and cables according to NEMA WC 26.

1.7 COORDINATION

- A. Coordinate layout and installation of cables with other installations.
- B. Revise locations and elevations from those indicated, as required to suit field conditions and as approved by Engineer or Owner's Representative.

PART 2 - PRODUCTS

2.1 MANUFACTURERS

- A. Manufacturers: Subject to compliance with requirements, provide products by one of the following:

- 1. Wires and Cables:

- a. Encore Wire Corp.
- b. Essex Group, Inc.
- c. General Wire & Cable.
- d. Okonite.
- e. Republic Wire & Cable.
- f. Southwire Company.

- 2. Connectors for Wires and Cables:

- a. Blackburn.
- b. Burndy Products, FCI.
- c. O-Z/Gedney.
- d. Ideal Industries.
- e. IlSCO.
- f. NSI Industries.
- g. Penn-Union
- h. 3M Company; Electrical Products Division.
- i. Thomas & Betts.

2.2 BUILDING WIRES AND CABLES

- A. UL-listed building wires and cables with conductor material, insulation type, cable construction, and rating as specified in Part 3 "Wire and Insulation Applications" Article.
- B. Thermoplastic Insulation Material: Comply with NEMA WC 5.
 - 1. Feeders and Branch Circuits 800 amps and Smaller: 600 volt insulation rated at 75 degrees C.
 - 2. Control Circuits: Solid conductor 600 volt insulation rated 60 degrees C.

3. Insulation shall be new, not greater than two years old.

C. Conductor Material: Copper.

D. Provide conductors as follows:

1. Provide solid conductors for wire size #14.
2. Provide stranded conductors for wire sizes #12 and larger.

2.3 CONNECTORS AND SPLICES

A. UL-listed, factory-fabricated wiring connectors of size, ampacity rating, material, type, and class for application and service indicated. Comply with requirements and as specified in Part 3 "Conductor Joints and Connections" Article.

PART 3 - EXECUTION

3.1 EXAMINATION

A. Examine raceways and building finishes to receive wires and cables for compliance with requirements for installation tolerances and other conditions affecting performance of wires and cables. Do not proceed with installation until unsatisfactory conditions have been corrected.

3.2 APPLICATION - DESIGN

A. The contractor shall coordinate all conduit sizes, base on fill capacities of currently adopted NFPA 70. Where indicated on the drawings, conduit sizes indicated on the construction documents are based on Type THHN and THWN wire. If other types of approved wiring are to be installed, the conduit sizes indicated shall be revised and based on the exact Type of wire to be installed.

B. Drawings may indicate panelboards and other devices with conductors larger than the factory installed terminals. The oversize conductors reduce the voltage drop of the feeders. The contractor shall review the project before submitting shop drawings and utilize one of the following means to terminate feeders with oversize conductors.

1. Conductors which are oversized for the lugs or terminals to which they are to be connected to, shall be reduced in size by splicing on a conductor of equal type and voltage rating, having a length less than 10 feet and an ampacity equal to or greater than the overcurrent protection for the conductors. This splice shall only be made by using a compression type connector, properly insulated and located as permitted by the applicable code. Conductor sizes shall not be reduced by cutting strands.
2. Provide panelboards or devices of larger ratings with larger factory installed terminals. The contractor shall be responsible for verifying that the increase in size of the components does not cause a conflict with other components being installed at the facility.

3.3 APPLICATIONS - WIRE AND INSULATION

- A. Feeders: Type THHN/THWN, in raceway.
- B. Branch Circuits: Type THHN/THWN, in raceway.
- C. Class 1 Control Circuits: Type THHN/THWN, in raceway.
- D. Class 2 Control Circuits: Type THHN/THWN or type as specified elsewhere in these specifications in raceway.
- E. Fire Alarm Circuits: Type THHN/THWN or type as specified elsewhere in these specifications, in raceway.

3.4 GENERAL METHODS

- A. Use no wire smaller than 12 AWG for power and lighting circuits, and no smaller than 14 AWG for control wiring.
- B. All 20 ampere, 120 volt branch circuit home run conductors (from panelboard to first junction box used for device or lighting connection) shall conform with the following schedule:

Conductor Size Schedule	
Distance	Conductor Sizes
0-50 Feet	#12/#12 Grnd.
51-84 Feet	#10/#10 Grnd.
85-124 Feet	#8/#10 Grnd.
125-199 Feet	#6/#10 Grnd.
200-300 Feet	#4/#8 Grnd.

- C. Grouping of Conductors: Conduits shall be limited to a maximum of nine branch circuit conductors of which a maximum of four phase conductors shall be permitted. Grounding conductors shall not be included in the count.
- D. Each 120 volt branch circuit and each 277 volt branch circuit shall have a neutral the same size as the respective phase conductor.

3.5 CONNECTIONS

- A. Conductor Splices: Keep to minimum. Splice branch circuits only in accessible junction or outlet boxes. Splicing of feeders will not be permitted except where allowed by the engineer in writing by special permission for specific application.
 - 1. Use solderless pressure connectors with insulating covers for copper wire splices and taps, 8 AWG and smaller. For 10 AWG and smaller, use insulated spring wire connectors with plastic caps.
 - 2. Use split bolt connectors for copper wire splices and taps, 6 AWG and larger. Tape-uninsulated conductors and connectors with electrical tape to 150 percent of the insulation value of conductor.

- B. Thoroughly clean wires before installing lugs and connectors.
- C. Install splices and tapes that possess equivalent or better mechanical strength and insulation ratings than conductors being spliced.
- D. Use splice and tap connectors compatible with conductor material.
- E. Wiring at Outlets: Install conductor at each outlet, with at least 12 inches of slack.
- F. Connect outlets and components to wiring and to ground as indicated and instructed by manufacturer.
- G. Terminate spare conductors with electrical tape.
- H. Tighten electrical connectors and terminals according to manufacturer's published torque-tightening values. If manufacturer's torque values are not indicated, use those specified in UL 486A and UL 486B.

3.6 INSTALLATION

- A. Install wires and cables as indicated, according to manufacturer's written instructions and NECA's "Standard of Installation."
- B. Identify wires and cables according to Division 26 Section "Electrical Identification."
- C. Neatly train and lace wiring inside boxes, equipment, and panelboards.
- D. Make Conductor lengths for parallel circuits equal.
- E. Neutral conductors shall be of same size as phase conductors, unless specifically noted otherwise.
- F. Pull Conductors: Use manufacturer-approved pulling compound or lubricant for #4AWG and larger conductors, or where necessary. Compound used must not deteriorate conductor or insulation. Do not exceed manufacturer's recommended maximum pulling tensions and sidewall pressure values.
- G. Use pulling means; including fish tape, cable, rope, and basket-weave wire/cable grips, that will not damage cables or raceway.
- H. Install exposed cables, parallel and perpendicular to surfaces of exposed structural members, and follow surface contours where possible.
- I. Seal around cables penetrating fire-rated elements according to Division 7 Section "Firestopping."
- J. Raceway Requirements:
 - 1. Run conductors of different voltage systems in separate conduits.
 - 2. Install wire in raceway after interior of building has been physically protected from the weather and all mechanical work likely to damage conductors has been completed.
 - 3. Completely and thoroughly swab raceway system before installing conductors.

4. Remove existing wires from raceway before pulling in new wires and cables.

3.7 CONDUCTOR JOINTS AND CONNECTIONS

A. #10 and Smaller Conductors

1. Pigtail conductors together before insulating.
2. Insulate with tape, insulated scotchlocks, or equal as approved by the Superintendent (copper sleeves not acceptable).
3. Fixture Connections: Mechanical type as approved by the Superintendent, where within fixture channel.
4. Solid Conductors
 - a. Terminate under screws, wrap conductor two-thirds to three-quarters of the distance around the screw post, in the direction of the screw tightening, and tighten to proper torque.
 - b. Terminate in lug type connector with pressure screw terminal and tighten to proper torque.
 - c. Pigtail and insulate solid conductors with twist-on, pressure type, self-insulated connectors as Ideal Wire Nuts, Scotch-Locks or equal installed per manufacturer's recommendations, to proper torque.

5. Stranded Conductors

- a. T & B "STA-KON" terminals with nylon self-insulated, insulation grip, fork type where under captive screws, ring type for bolted connections, installed with proper ratchet type hand tool, and torque the screws or bolts.
- b. "STA-KON" terminals not required where stranded conductors are terminated in a lug type connector with pressure screw terminal, tightened to proper torque.
- c. Pigtail and insulate stranded conductors with twist-on, pressure type, self-insulated connectors as Ideal Wire Nuts, Scotch-Locks or equal installed per manufacturer's recommendations, to proper torque.

- #### B. Motor Connections (480V or less): For #10 AWG and smaller conductors, provide taped connector spade lug of motor lead to looped input conductors, using machine bolt/nut arrangement to facilitate rapid disconnecting.

C. Lugs and Gutter Taps for #8 and Larger Connections

1. All lugs shall be as follows:
 - a. Listed for "CU/AL" or "CU" only.
 - b. Aluminum or Copper alloy construction.
 - c. Mechanical screw type or pressure indenting type with two indents when possible.
 - d. Two-hole type where for 250 MCM and larger where installed on Bolted Pressure Contact switches.
 - e. Complete with machined contact surfaces.
 - f. Only one conductor permitted for each barrel of lug.
 - g. UL listed with equipment where installed on switches, motor controllers, transformers, and other equipment where required by UL testing procedures.
2. Torque all lug connections to cables and to bus per manufacturer's recommendations.

3. Gutter Taps: #8 and larger parallel gutter taps shall be Silicon Bronze or copper alloy, tee or parallel gutter taps, with a minimum of two bolts and a separate section for each conductor. Burndy QPX, Dossert GT, Kupler KUL-L-TAP, OZ/Gedney XTP or PMX, PENN-UNION VX, or equal with insulating cover or heavy tape insulation.

D. Shop Drawing Submittals:

1. Submit catalog cut sheets and a listing of lugs proposed to be furnished with the shop drawings for each and every piece of equipment requiring lugs.
2. Submit samples of proposed lugs for approval when requested.

E. Tape

1. For 600-volt Insulated Conductors
2. Normal temperature installations: Scotch #33, 88.
3. For wet locations: Self-vulcanizing rubber insulating tape equal to Scotch #2210 with vinyl tape outer coat.

3.8 FIELD QUALITY CONTROL

- A. Inspect wire and cable for physical damage and proper connection.
- B. Torque test conductor connections and terminations to manufacturer's recommended values.
- C. Perform continuity test on all power and equipment branch circuit conductors. Verify proper phasing connections.
- D. Procedures: Perform each visual and mechanical inspection and electrical test stated in NETA ATS, Section 7.3.1. Certify compliance with test parameters.
- E. Correct malfunctioning conductors and cables at Project site, where possible, and retest to demonstrate compliance; otherwise, remove and replace with new units and retest.

END OF SECTION 262101

SECTION 262300 – ENCLOSED SWITCHES AND CIRCUIT BREAKERS

PART 1 - GENERAL

1.1 RELATED DOCUMENTS

- A. Drawings and general provisions of the Contract, including General and Supplementary Conditions and Division 1 Specification Sections, apply to this Section.
- B. Related Sections include the following:
 - 1. Division 26 Section "Basic Electrical Requirements."
 - 2. Division 26 Section "Grounding and Bonding for Electrical Systems."
 - 3. Division 26 Section "Electrical Identification."

1.2 SUMMARY

- A. This Section includes individually mounted enclosed switches and circuit breakers used for the following:
 - 1. Feeder and branch-circuit protection.
 - 2. Equipment disconnecting means.
 - 3. Circuit breakers and fusible switches installed in existing electrical equipment.

1.3 DEFINITIONS

- A. GFI: Ground-fault interrupter - personnel.
- B. GFPE: Ground-fault protector - equipment.
- C. RMS: Root mean square.
- D. SPDT: Single pole, double throw.

1.4 SUBMITTALS

- A. Product Data: For each type of switch, circuit breaker, accessory, and component indicated. Include dimensions and manufacturers' technical data on features, performance, electrical characteristics, ratings, and finishes.
- B. Shop Drawings: For each switch and circuit breaker.
 - 1. Dimensioned plans, elevations, sections, and details, including required clearances and service space around equipment. Show tabulations of installed devices, equipment features, and ratings. Include the following:
 - a. Enclosure types and details for types other than NEMA 250, Type 1.

- b. Current and voltage ratings.
 - c. Short-circuit current rating. Features, characteristics, ratings, and factory settings of individual overcurrent protective devices and auxiliary components.
- C. Wiring Diagrams: Power, signal, and control wiring. Differentiate between manufacturer-installed and field-installed wiring.
- D. Maintenance Data: For enclosed switches and circuit breakers and for components to include in maintenance manuals specified in Division 1. In addition to requirements specified in Division 1 Section "Closeout Procedures," include the following:
- 1. Routine maintenance requirements for components.
 - 2. Manufacturer's written instructions for testing and adjusting switches and circuit breakers.
 - 3. Time-current curves, including selectable ranges for each type of circuit breaker.

1.5 OPERATION AND MAINTENANCE DATA

- A. Submit written test reports as required by in Part 3 and include the following:
- 1. Test procedures used.
 - 2. Test results that comply with requirements.
 - 3. Results of failed tests and corrective action taken to achieve test results that comply with requirements.

1.6 QUALITY ASSURANCE

- A. Electrical Components, Devices, and Accessories: Listed and labeled as defined in NFPA 70, Article 100, by a testing agency acceptable to authorities having jurisdiction, and marked for intended use.
- B. Comply with NEMA AB 1 and NEMA KS 1.
- C. Comply with NFPA 70.

1.7 PROJECT CONDITIONS

- A. Existing Utilities: Do not interrupt utilities serving facilities occupied by Owner or others unless permitted under the following conditions and then only after arranging to provide temporary utility services:
- 1. Notify Architect at least two days in advance of proposed utility interruptions. Identify extent and duration of utility interruptions.
 - 2. Indicate method of providing temporary utilities.
 - 3. Do not proceed with utility interruptions without Owner Representative's written permission.

1.8 COORDINATION

- A. Coordinate layout and installation of switches, circuit breakers, and components with other construction, including conduit, piping, equipment, and adjacent surfaces. Maintain required workspace clearances and required clearances for equipment access doors and panels.

PART 2 - PRODUCTS

2.1 MANUFACTURERS

- A. Manufacturers: Subject to compliance with requirements, provide products by one of the following:
 - 1. Eaton.
 - 2. Siemens Energy & Automation, Inc.
 - 3. Square D Co.

2.2 ENCLOSED SWITCHES

- A. Fusible and Nonfusible Switches: Switch mechanism shall have a visible blade design with double break wiping contacts.
- B. Enclosed, Nonfusible Switches: NEMA KS 1, Type HD "Heavy Duty", with lockable handle with three padlocks, and interlocked with cover in the closed position.
- C. Enclosed, Fusible Switches: NEMA KS 1, Type HD "Heavy Duty", with clips to accommodate specified fuses, lockable handle with three padlocks, and interlocked with cover in closed position.
- D. Switches shall be:
 - 1. Square D Class 3110
 - 2. Siemens "VBII" Series
 - 3. Equal as manufactured by Eaton

2.3 ENCLOSED CIRCUIT BREAKERS

- A. Molded-Case Circuit Breaker: NEMA AB 1, with interrupting capacity to meet available fault currents.
 - 1. Thermal-Magnetic Circuit Breakers: Inverse time-current element for low-level overloads, and instantaneous magnetic trip element for short circuits. Adjustable magnetic trip setting for circuit-breaker frame sizes over 225A shall have LSI adjustable electronic trip units.
- B. Adjustable Instantaneous-Trip Circuit Breakers: Magnetic trip element with front-mounted, field-adjustable trip setting.

- C. Electronic Trip Unit Circuit Breakers: RMS sensing; field-replaceable rating plug; with the following field-adjustable settings:
- D. Instantaneous trip.
- E. Long- and short-time pickup levels.
- F. Long- and short-time time adjustments.
- G. Ground-fault pickup level, time delay, and I²t response.
- H. GFPE Circuit Breakers: Single- and two-pole configurations with [5] [30]-mA trip sensitivity.
- I. Lugs: Mechanical style suitable for number, size, trip ratings, and material of conductors.
- J. Application Listing: Appropriate for application; Type SWD for switching fluorescent lighting loads; Type HACR for heating, air-conditioning, and refrigerating equipment.
- K. Ground-Fault Protection: Integrally mounted relay and trip unit with adjustable pickup and time-delay settings, push-to-test feature, and ground-fault indicator.
- L. Shunt Trip: 120-V trip coil energized from separate circuit, set to trip at 75 percent of rated voltage.
- M. Undervoltage Trip: Set to operate at 35 to 75 percent of rated voltage with field-adjustable 0.1- to 0.6-second time delay.
- N. Auxiliary Switch: Two SPDT switches with "a" and "b" contacts; "a" contacts mimic circuit-breaker contacts, "b" contacts operate in reverse of circuit-breaker contacts.

2.4 ENCLOSURES

- A. NEMA AB 1 and NEMA KS 1 to meet environmental conditions of installed location.
 - 1. Outdoor Locations: NEMA 250, Type 3R.

2.5 FACTORY FINISHES

- A. Finish: Manufacturer's standard gray paint applied to factory-assembled and -tested enclosures before shipping.

2.6 SHORT CIRCUIT RATINGS

- A. Provide components with the following minimum interrupting capacity or higher ratings as indicated on the drawings:
 - 1. 208/120 volt circuit breakers: 75,000 AIC
 - 2. 240/120 volt circuit breakers: 75,000 AIC
 - 3. All fusible equipment: 100,000 AIC

- B. Components shall be fully rated for available fault current; series rated components are not acceptable.

2.7 ACCESSORIES

- A. For all disconnect switches installed locally at a motor feed from a Variable Frequency Drive, provide an auxiliary contact (operating in unison with the disconnect position) wired to the VFD to indicate the disconnect status of the local disconnecting means. The contact shall consist of a normally open electrical interlock consisting of a pivot arm from the switch mechanism that will break the control circuit to the VFD before the main switch blades and make the control circuit to the VFD before the main switch blades.

PART 3 - EXECUTION

3.1 EXAMINATION

- A. Examine elements and surfaces to receive enclosed switches and circuit breakers for compliance with installation tolerances and other conditions affecting performance.
 - 1. Proceed with installation only after unsatisfactory conditions have been corrected.

3.2 APPLICATIONS

- A. Provide NEMA 3R rated components where installed on the exterior.
- B. Provide fused switches, non-fused switches, & enclosed circuit breakers at locations as indicated on the drawings. Where unit is to be installed in existing electrical equipment, provide unit compatible with the existing equipment.
- C. Provide fused switches or non-fused switches as required by NFPA 70 at each piece of motorized equipment. Where unit is to be installed in existing electrical equipment, provide unit compatible with the existing equipment.

3.3 INSTALLATION

- A. Temporary Lifting Provisions: Remove temporary lifting eyes, channels, and brackets and temporary blocking of moving parts from enclosures and components.
- B. All new circuit breakers installed in existing panelboards and switchboards shall have a minimum AIC UL rating equal to or greater than the smallest rating of the existing original devices in the existing panelboard or switchboard.

3.4 CONNECTIONS

- A. Install equipment grounding connections for switches and circuit breakers with ground continuity to main electrical ground bus.

- B. Install power wiring. Install wiring between switches and circuit breakers, and control and indication devices.
- C. Tighten electrical connectors and terminals according to manufacturer's published torque-tightening values. If manufacturer's torque values are not indicated, use those specified in UL 486A and UL 486B.

3.5 FIELD QUALITY CONTROL

- A. Prepare for acceptance tests as follows:
 - 1. Test insulation resistance for each enclosed switch, circuit breaker, component, and control circuit.
 - 2. Test continuity of each line- and load-side circuit.
- B. Testing: After installing enclosed switches and circuit breakers and after electrical circuitry has been energized, demonstrate product capability and compliance with requirements.
 - 1. Procedures: Perform each visual and mechanical inspection indicated in NETA ATS, Section 7.5 for switches and Section 7.6 for molded-case circuit breakers. Certify compliance with test parameters.
 - 2. Correct malfunctioning units on-site, where possible, and retest to demonstrate compliance; otherwise, replace with new units and retest.

3.6 ADJUSTING

- A. Set field-adjustable switches and circuit-breaker trip ranges.

3.7 IDENTIFICATION

- A. Identify components as specified in Division 26 Section "Electrical Identification."

3.8 CLEANING

- A. On completion of installation, inspect interior and exterior of enclosures. Remove paint splatters and other spots. Vacuum dirt and debris; do not use compressed air to assist in cleaning. Repair exposed surfaces to match original finish.

END OF SECTION 262300

SECTION 262416 - PANELBOARDS

PART 1 - GENERAL

1.1 RELATED DOCUMENTS

- A. Drawings and general provisions of the Contract, including General and Supplementary Conditions and Division 1 Specification Sections, apply to this Section.
- B. Related Sections include the following:
 - 1. Division 26 Section "Basic Electrical Requirements."
 - 2. Division 26 Section "Electrical Identification."
 - 3. Division 26 Section "Grounding and Bonding for Electrical Systems."

1.2 SUMMARY

- A. This Section includes overcurrent protective devices, and associated auxiliary equipment for existing panelboards rated 600 V and less for the following types:
 - 1. Lighting and appliance branch-circuit panelboards.

1.3 DEFINITIONS

- A. EMI: Electromagnetic interference.
- B. GFI: Ground-fault interrupter - personnel.
- C. GFPE: Ground-fault protector - equipment.
- D. RFI: Radio-frequency interference.
- E. RMS: Root mean square.
- F. SPDT: Single pole, double throw.

1.4 SUBMITTALS

- A. Product Data: For each type of panelboard, overcurrent protective device, accessory, and component indicated. Include dimensions and manufacturers' technical data on features, performance, electrical characteristics, ratings, and finishes.
- B. Shop Drawings: For each panelboard and related equipment.
- C. Dimensioned plans, elevations, sections, and details. Show tabulations of installed devices, equipment features, and ratings. Include the following:

1. Enclosure types and details
2. Short-circuit current rating of panelboards and overcurrent protective devices.
3. Features, characteristics, ratings, and factory settings of individual overcurrent protective devices and auxiliary components.
4. Wiring Diagrams: Diagram power, signal, and control wiring and differentiate between manufacturer-installed and field-installed wiring.

1.5 OPERATION AND MAINTENANCE DATA

- A. Submit written test reports as required by in Part 3 and include the following:
1. Test procedures used.
 2. Test results that comply with requirements.
 3. Results of failed tests and corrective action taken to achieve test results that comply with requirements.
- B. Maintenance Data: Include in maintenance manuals for components as specified in Division 1. In addition to requirements specified in Division 1 Section "Contract Closeout," include the following:
1. Routine maintenance requirements for all installed components.
 2. Manufacturer's written instructions for testing and adjusting overcurrent protective devices.
 3. Time-current curves, including selectable ranges for each type of overcurrent protective device.

1.6 QUALITY ASSURANCE

- A. Electrical Components, Devices, and Accessories: Listed and labeled as defined in NFPA 70, Article 100, by a testing agency acceptable to authorities having jurisdiction, and marked for intended use.
- B. Comply with NEMA PB 1.
- C. Comply with NFPA 70.

1.7 PROJECT CONDITIONS

- A. Existing Utilities: Do not interrupt utilities serving facilities occupied by Owner or others unless permitted under the following conditions and then only after arranging to provide temporary utility services:
1. Notify the Architect or Owner's Representative at least seven(7) days in advance of proposed utility interruptions. Identify extent and duration of utility interruptions.
 2. Indicate method of providing temporary utilities.
 3. Do not proceed with utility interruptions without the Architect's or Owner's Representative's written permission.

1.8 COORDINATION

- A. Coordinate layout and installation of panelboards and components with other construction that penetrates walls or is supported by them, including electrical and other types of equipment, raceways, piping, and encumbrances to workspace clearance requirements.

PART 2 - PRODUCTS

2.1 MANUFACTURERS

- A. Design Basis Manufacturers: Where listed in each respective product specification or as listed below, the "Design Basis Manufacturer" product series number or name shall serve to indicate the level of quality and minimum requirements for the product to be furnished.
 - 1. 225 Ampere and smaller circuit breaker panelboards:
 - a. Existing panelboard located in Room 4166 is a Westinghouse W10B series. Provide new branch circuit breakers and accessories compatible with existing panelboard.
- B. Acceptable Manufacturers: Where acceptable manufacturers are listed in each respective product specification or as listed below, this shall be interpreted to mean that products by the listed manufacturers will be acceptable as equals to the "Design Basis Manufacturer" product provided that the manufacturer demonstrates full compliance with all of the requirements contained in these specifications.
 - 1. Other manufacturers as pre-approved by the Engineer and added by written addendum.

2.2 SHORT-CIRCUIT RATING

- A. Fully rated to interrupt symmetrical short-circuit current available at terminals.
- B. Short Circuit Ratings: Provide the following minimum interrupting capacity or higher ratings as indicated on the drawings:
 - 1. Match existing panelboard AIC rating.

2.3 MOLDED-CASE CIRCUIT BREAKERS

- A. General Requirements:
 - 1. Units shall meet NEMA AB 1, in standard frame sizes, trip ratings, and number of poles as indicated, with interrupting capacity to meet specification requirements.
 - 2. Provide options and features as indicated on the drawings or other specification sections. Features shall meet the requirements as described in this subparagraph.
 - 3. Lugs: Mechanical or compression style, suitable for number, size, trip ratings, and material of conductors.
 - 4. Application Listing: As indicated in the construction documents, required by codes, appropriate for the application, or recommended by the manufacturer for the application.

- a. Switching lighting loads (SWD)
 - b. Heating, Air-conditioning, and refrigeration loads (HACR).
 - c. LED lighting loads.
 - d. High inrush current loads.
 - e. Ground-fault person protection.
 - f. Ground-fault equipment protection.
- B. Provide the following features where indicated on the drawings:
1. Ground-Fault Protection: Integrally mounted relay and trip unit with adjustable pickup and time-delay settings, push-to-test feature, and ground-fault indicator.
- C. Thermal-Magnetic Circuit Breakers: Inverse time-current element for low-level overloads, and instantaneous magnetic trip element for short circuits.
1. Circuit breakers for "400A" and smaller branch circuit panelboards.
 - a. Match existing panelboard manufacturer, or new compatible devices, for each panelboard modified under project.
 - b. Match existing panelboard AIC rating.

PART 3 - EXECUTION

3.1 INSTALLATION

- A. Install panelboards and accessories according to NEMA PB 1.1.
- B. Circuit Directory: Create a directory to indicate installed circuit loads after balancing panelboard loads. Use a computer or typewriter to create directory; handwritten directories are not acceptable.
- C. Wiring in Panelboard Gutters: Arrange conductors into groups and bundle and wrap with wire ties after completing load balancing.
- D. Install filler plates in unused spaces.
- E. Arc Flash Warning Label: Existing to remain.

3.2 CONNECTIONS

- A. Install equipment grounding connections for panelboards with ground continuity to main electrical ground bus.
- B. Tighten electrical connectors and terminals according to manufacturer's published torque-tightening values. If manufacturer's torque values are not indicated, use those specified in UL 486A and UL 486B.

3.3 FIELD QUALITY CONTROL

- A. Prepare for acceptance tests as follows:
 - 1. Test insulation resistance for each panelboard bus, component, connecting supply, feeder, and control circuit.
 - 2. Test continuity of each circuit.

3.4 TESTING

- A. Testing: After installing panelboards and after electrical circuitry has been energized, demonstrate product capability and compliance with requirements.
 - 1. Procedures: Perform each visual and mechanical inspection and electrical test indicated in NETA ATS, Section 7.5 for switches and Section 7.6 for molded-case circuit breakers. Certify compliance with test parameters.
 - 2. Correct malfunctioning units on-site, where possible, and retest to demonstrate compliance; otherwise, replace with new units and retest.
- B. Balancing Loads: After Substantial Completion, but not more than 60 days after Final Acceptance, measure load balancing and make circuit changes as follows:
 - 1. Measure as directed during period of normal system loading.
 - 2. Perform load-balancing circuit changes outside normal occupancy/working schedule of the facility and at time directed. Avoid disrupting critical 24-hour services such as fax machines and on-line data-processing, computing, transmitting, and receiving equipment.
 - 3. After circuit changes, recheck loads during normal load period. Record all load readings before and after changes and submit test records.
 - 4. Tolerance: Difference exceeding 20 percent between phase loads, within a panelboard, is not acceptable. Rebalance and recheck as necessary to meet this minimum requirement.

3.5 ADJUSTING

- A. Set field-adjustable switches and circuit-breaker trip ranges.

3.6 IDENTIFICATION

- A. Identify components as specified in Division 26 Section "Electrical Identification."

3.7 CLEANING

- A. On completion of installation, inspect interior and exterior of panelboards. Remove paint splatters and other spots. Vacuum dirt and debris; do not use compressed air to assist in cleaning. Repair exposed surfaces to match original finish.

END OF SECTION 262416

SECTION 262725 – BOXES AND ENCLOSURES

PART 1 - GENERAL

1.1 RELATED DOCUMENTS

- A. Drawings and general provisions of the Contract, including General and Supplementary Conditions and Division 1 Specification Sections, apply to this Section.

1.2 SUMMARY

- A. This Section includes boxes, enclosures, and cabinets for electrical wiring.
- B. This section includes floor boxes and poke-throughs.
- C. Related Sections include the following:
 - 1. Division 26 Sections “Raceways and Fittings” for raceways, wireways, and fittings.

1.3 GENERAL

- A. Every switch, luminaire (light fixture), receptacle, signal device, telecommunications outlet, etc. shall be provided with an outlet box.
- B. All boxes shall be of suitable size as required by NFPA 70; National Electrical Code (N.E.C.).
- C. All boxes shall be U.L. listed.
- D. All sheet metal boxes shall be constructed of not less than #14 U.S. Gauge galvanized steel and shall have “hot dipped” finish where available.

1.4 SUBMITTALS

- A. Product Data: For outlet boxes, pull boxes, hinged-cover enclosures, and cabinets.
- B. Shop Drawings: For the following components. Provide plans, elevations, sections, details, and attachments to other work.
 - 1. Custom enclosures and cabinets.

1.5 QUALITY ASSURANCE

- A. Electrical Components, Devices, and Accessories: Listed and labeled as defined in NFPA 70, Article 100, by a testing agency acceptable to authorities having jurisdiction, and marked for intended use.

- B. Comply with NFPA 70, National Electrical Code (N.E.C.).

PART 2 - PRODUCTS

2.1 BOXES, ENCLOSURES, AND CABINETS

- A. Manufacturers: Subject to compliance with requirements, provide products by one of the following:

1. Cooper Crouse-Hinds; Div. of Cooper Industries, Inc.
2. EGS/Appleton Electric.
3. Erickson Electrical Equipment Company.
4. Hoffman.
5. Hubbell Incorporated; Killark Electric Manufacturing Co. Division.
6. O-Z/Gedney; a unit of General Signal.
7. RACO; a Hubbell Company.
8. Thomas & Betts Corporation.
9. Wiremold Company (The).

- B. Sheet Metal Outlet and Device Boxes: NEMA OS 1.

- C. Cast-Metal Outlet and Device Boxes:

1. NEMA FB 1.
2. Zinc electroplate galvanized.
3. Type FD.
4. Ferrous alloy with gasketed cover.
5. Epoxy spray finish.

- D. Nonmetallic Outlet and Device Boxes:

1. NEMA OS 2.

- E. Small Sheet Metal Pull and Junction Boxes:

1. NEMA OS 1.
2. #14 U.S. gauge galvanized steel minimum.
3. Hot-dipped galvanized finish.

- F. Cast-Metal Access, Pull, and Junction Boxes:

1. NEMA FB 1
2. Zinc electroplate galvanized.
3. Cast iron with gasketed cover.
4. Epoxy spray finish.

- G. Hinged-Cover Enclosures: NEMA 250, Type 1, with continuous-hinge cover with flush latch, unless otherwise indicated.

1. Metal Enclosures: Steel, finished inside and out with manufacturer's standard enamel.

H. Cabinets:

1. NEMA 250, Type 1, galvanized-steel box with removable interior panel and removable front, finished inside and out with manufacturer's standard enamel.
2. Hinged door in front cover with flush latch and concealed hinge.
3. Key latch to match panelboards.
4. Metal barriers to separate wiring of different systems and voltage.
5. Accessory feet where required for freestanding equipment.

PART 3 - EXECUTION

3.1 OUTLET AND PULL BOX APPLICATION

A. Interior Surface Mounted Luminaires: Boxes shall:

1. Be four inch octagonal or square as required.
2. Have minimum depth of 2-1/8".
3. Be provided with 3/4" minimum deep square cut tile ring in suspended ceilings.
4. Be furnished with fixture studs as applicable.
5. Be supported for suspended ceilings utilizing bar hangers or 1-1/4" lathers channel, securely attached to the building construction.
6. Be 3-1/2" – 4" deep cast box for poured concrete ceiling construction wherever slab depth permits.

B. Recessed Luminaires: Boxes shall

1. Be four inch octagonal or square as required.
2. Have minimum depth of 1-1/2".
3. Be furnished complete with blank cover plate.
4. Be installed in an accessible location.
5. Be installed with FMC conduit from outlet box to luminaire.

C. Interior Switch, Receptacles and Wall Bracket Fixtures: Boxes shall:

1. Be four inch octagonal or square as required.
2. Have minimum depth of 2-1/8".
3. Be furnished complete with welded square cut tile ring or square drawn tile ring for all flush locations.
 - a. The depth of the ring shall be such that the ring is flush with the finished surface.
 - b. All cracks and fillets between the wall surface and the ring shall be filled and/or patched.
 - c. Rings shall be equal to RACO #768, 769, 773-796.
4. Properly supported and complete with fixture studs for wall bracket fixtures.
5. Located at top or bottom of masonry course.
6. Staggered approximately 12" apart where located back to back to prevent sound transmission.

D. Exterior Switch, Receptacles and Wall Bracket Fixtures: Boxes shall:

1. Cast ferrous type, zinc electroplate with epoxy spray finish for all vaportight and watertight fixtures in tunnels, exterior, vaults.

E. Pull and Junction Boxes: Boxes shall:

1. Be installed in all runs of conduit exceeding the equivalent of three (3) 90 degree bends for building wiring and cabling.
2. Be installed in all runs of conduit more than 100 feet in length.
3. Be installed in locations that are entirely accessible.
4. Be furnished complete with covers of the same gauge as the boxes. Covers shall be secured to the boxes with screws.
5. Have reinforcement as required due to size.
6. Be #14 gauge minimum hot dipped galvanized steel for sizes up to 12" by 12".
7. Be #12 gauge minimum hot dipped galvanized steel for sizes over 12" by 12".

3.2 INSTALLATION

- A. Comply with NECA 1 for installation requirements applicable to products specified in Part 2 except where requirements on Drawings or in this Article are stricter.
- B. All unused conduit openings shall be closed with knockout closures.

3.3 PROTECTION

- A. Provide final protection and maintain conditions that ensure coatings, finishes, and cabinets are without damage or deterioration at time of Substantial Completion.
 1. Repair damage to galvanized finishes with zinc-rich paint recommended by manufacturer.
 2. Repair damage to PVC or paint finishes with matching touchup coating recommended by manufacturer.

END OF SECTION 262725

SECTION 262726 – WIRING DEVICES

PART 1 - GENERAL

1.1 RELATED DOCUMENTS

- A. Drawings and general provisions of the Contract, including General and Supplementary Conditions and Division 1 Specification Sections, apply to this Section.
- B. Related Sections include the following:
 - 1. Division 26 Section "Basic Electrical Requirements".
 - 2. Division 26 Section "Raceways and Fittings".
 - 3. Division 26 Section "Boxes and Enclosures".
 - 4. Division 26 Section "Conductors and Cables".
 - 5. Division 26 Section "Electrical Identification".

1.2 SUMMARY

- A. This Section includes the following:
 - 1. Device & Wall Plates.
 - 2. Receptacles.
 - 3. Switches

1.3 DEFINITIONS

- A. GFCI: Ground-fault circuit interrupter.

1.4 SUBMITTALS

- A. Product Data: For each product specified.
- B. Shop Drawings: Legends for receptacles and switch plates.
- C. Maintenance Data: For materials and products to include in maintenance manuals specified in Division 1.

1.5 QUALITY ASSURANCE

- A. Electrical Components, Devices, and Accessories: Listed and labeled as defined in NFPA 70, Article 100, by a testing agency acceptable to authorities having jurisdiction.
- B. Comply with NEMA WD 1.
- C. Comply with NFPA 70.

- D. All devices shall be UL listed for stranded conductors, see Division 16/26 Section "Conductors and Cables" for approved wiring methods.

1.6 COORDINATION

- A. Receptacles for Owner-Furnished Equipment: Match plug configurations.
- B. Cord and Plug Sets: Match equipment requirements.

PART 2 - PRODUCTS

2.1 MANUFACTURERS

- A. Manufacturers: Subject to compliance with the specifications, provide products by one of the following:
 - 1. Devices, general wiring devices:
 - a. Cooper/Arrow Hart Wiring Devices.
 - b. Hubbell, Inc.; Wiring Devices Div.
 - c. Leviton Manufacturing Co., Inc.
 - d. Pass & Seymour/Legrand; Wiring Devices Div.

2.2 CORD AND PLUG SETS

- A. Description: Match voltage and current ratings and number of conductors to requirements of equipment being connected.
- B. Cord: Rubber-insulated, stranded-copper conductors, with type SOW-A jacket. Green-insulated grounding conductor, and equipment-rating ampacity plus a minimum of 30 percent.
- C. Plug: Nylon body and integral cable-clamping jaws. Match cord and receptacle type for connection.

2.3 DEVICE & WALL PLATES

- A. Interior General Use Wall Plates:
 - 1. Single and combination types shall match corresponding wiring devices.
 - a. Plate-Securing Screws: Metal with head color to match plate finish.
 - 2. Where special designer coverplates are specified or required for special conditions, provide a designer type device equal to units listed above.
 - 3. Plates shall be high impact nylon or stainless steel as selected by the Architect. Note that different types may be selected for different areas of this project.
 - 4. Where specifically noted and shown provide the following plates for devices:

- a. Steel with wrinkled finish, white baked enamel, suitable for field painting.
 - b. 0.04-inch- thick, Type 302, satin-finished stainless steel.
 - c. 0.04-inch- thick brushed brass with factory polymer finish.
 - d. 0.04-inch- thick brass, satin chrome-plated.
5. High impact nylon plates shall be:
- a. Cooper/Arrow Hart #5100 Series.
 - b. Hubbell Nylon "P" Series.
 - c. Leviton #80700 Series.
 - d. Pass & Seymour/Legrand "TP" Series.
6. Stainless steel plates shall be:
- a. 0.040 thick stainless steel, Type 302.
 - b. Smooth brushed finish.
 - c. Stainless steel plates for receptacles on "emergency" power circuits shall have engraved lettering with red paint fill marked "EMERGENCY".
7. Colors: Unless specifically noted otherwise, colors for all high impact nylon plates shall be as follows:
- a. As selected by the Architect for all receptacles on "normal" power circuits and all switches. Note that different colors may be selected by the Architect for different areas of this project.
 - b. Ivory for all switch plates.
 - c. Ivory for all receptacle plates.
8. Surface boxes: Galvanized cover plate in mechanical rooms.

2.4 EXTERIOR DEVICES

A. Exterior devices shall be installed utilizing weatherproof components as follows:

1. Duplex Receptacle, "While-In-Use" Coverplate:
 - a. Description: Cast aluminum, vertical mounted, 6.13" high by 3.38" wide by 3.5" deep maximum dimensions, NEMA 3R.
 - b. Design Basis Manufacturer: Hubbell #WP8M.
2. GFCI Duplex Receptacle, "While-In-Use" Coverplate:
 - a. Description: Cast aluminum, vertical mounted, 6.13" high by 3.38" wide by 3.5" deep maximum dimensions, NEMA 3.
 - b. Design Basis Manufacturer: Hubbell #WP26M.
3. Single Receptacle, "While-In-Use" Coverplate:
 - a. Description: Cast aluminum, vertical mounted, 6.13" high by 3.38" wide by 5.00" deep maximum dimensions, NEMA 3R.
 - b. Design Basis Manufacturer: Hubbell #WP7 Series.

B. Devices installed in exterior walls or on grade shall be installed with the following components:

1. Weatherproof gasket on coverplate.

2.5 PENDANT CORD REEL SETS

A. Description: Provide industrial grade 25-foot electric cord reels of steel construction and heavy-duty cord and outlet set. Nominal size of 14" x 14" x 10" wide. Unit shall include positive-latching mechanism, multidirectional cord guides, adaptable for ceiling, wall, floor or bench mounting. Provide locking type, plug and receptacle body connector, NEMA WD 6, Heavy-Duty grade outlet configuration L5-20R, unless noted otherwise on the drawings.

B. Basis of design:

1. Hubbell #HBLI25123GF220M1 with (2) 20A duplex receptacles and in-line GFCI protection.

2.6 RECEPTACLES

A. General Use Duplex Receptacles:

1. General duplex receptacles shall be back and side wired type.
2. Back and Side Wired Type: NEMA 5-20R, 20A, 120 volt, three wire grounding type, heavy duty, specification grade, nylon face, back and side wired, one piece brass mounting strap, U.L. listed, Fed. Spec. WC596F listed.
 - a. Manufacturer: Cooper/Arrow Hart #AH5362; Hubbell #HBL5362; Leviton #5362; Pass & Seymour #5362A.

B. General Use Ground Fault Interrupter (GFCI) Duplex Receptacles:

1. Description: NEMA 5-20R, 20A, 120 volt, three wire grounding type, heavy duty, specification grade, nylon face, back and side wired, steel mounting strap, power indicator light, reverse wiring protection, UL943 Class A and UL498 listed.
2. Manufacturer: Cooper/Arrow Hart #VGF20; Hubbell #GF20L; Leviton #7899; Pass & Seymour #2095xL.

C. Tamper/Weather Resistant Ground Fault Interrupter (GFCI) Duplex Receptacles:

1. Description: NEMA 5-20R, 20A, 120 volt, three wire grounding type, heavy duty, specification grade, nylon face, back and side wired, steel mounting strap, tamper-resistant, weather-resistant, power indicator light, reverse wiring protection, UL943 Class A and UL498 listed.
2. Manufacturer: Cooper/Arrow Hart #TWRVGF20; Hubbell #GFR5362SG; Pass & Seymour #2095TRWR.

D. Locking-Blade Receptacles: NEMA WD5.

E. Specific Use Receptacle Configuration: Type as indicated on drawings or as required by the specific item of equipment, black phenolic face. Receptacles shall be provided per "Receptacle Configuration Table":

Receptacle Configuration Table					
Voltage/Phase	NEMA Configuration	Ampacity	Cord	Receptacle	Plug
125 VAC 1 ϕ	5-15	0-15A	3/c #14 AWG	HBL5261	HBL5266C
	5-20	15-20A	3/c #12 AWG	HBL5361	HBL5366C
	5-30	20-30A	3/c #10 AWG	HBL9308	HBL9309
	5-50	30-50A	3/c #6 AWG	HBL9360	HBL9361
250 VAC 3 ϕ	6-15	0-15A	3/c #14 AWG	HBL5661	HBL5666C
	6-20	15-20A	3/c #12 AWG	HBL5461	HBL5466C
	6-30	20-30A	3/c #10 AWG	HBL9330	HBL9331
	6-50	30-50A	3/c #6 AWG	HBL9367	HBL9368
125/250 VAC 3 ϕ	14-20	15-20A	4/c #12 AWG	HBL8410	HBL8411C
	14-30	20-30A	4/c #8 AWG	HBL9430A	HBL9431C
	14-50	30-50A	4/c #4 AWG	HBL9450A	HBL9451C
	14-60	50-60A	4/c #4 AWG	HBL9460A	HBL9461C
250 VAC 3 ϕ	15-20	15-20A	4/c #12 AWG	HBL8420A	HBL8421C
	15-30	20-30A	4/c #8 AWG	HBL8430A	HBL8431C
	15-50	30-50A	4/c #4 AWG	HBL8450A	HBL8451C
	15-60	50-60A	4/c #4 AWG	HBL8460A	HBL8461C
<p><u>Notes:</u></p> <p>1. All model numbers are for equipment manufactured by Hubbell Wiring Devices. Equivalent products by Cooper, Leviton, or Pass & Seymour will be acceptable.</p>					

F. Colors: Colors for all receptacles shall be:

1. As selected by the Architect for all receptacles on "normal" power circuits. Note that different colors may be selected by the Architect for different areas of this project.
2. Ivory for all receptacles.
3. Ivory for all receptacles on "normal" power circuits, unless specifically noted otherwise.

2.7 SWITCHES

A. General Use Switches:

1. 20A, 120/277 volt AC, heavy duty, back and side wired, U.L. listed, Fed. Spec. WS896E listed. Provide single pole, double pole, three way and/or four way switches as required and/or as shown on the drawings.
2. Single Pole Switches: Cooper/Arrow Hart #AH1221; Hubbell #HBL1221; Leviton #1221-2; Pass & Seymour #PS20AC1.
3. Double Pole Switches: Cooper/Arrow Hart #AH1222; Hubbell #HBL1222; Leviton #1222-2; Pass & Seymour #PS20AC2.
4. Three Way Switches: Cooper/Arrow Hart #AH1223; Hubbell #HBL1223; Leviton #1223-2; Pass & Seymour #PS20AC3.
5. Four Way Switches: Cooper/Arrow Hart #AH1224; Hubbell #HBL1224; Leviton #1224-2; Pass & Seymour #PS20AC4.
6. Key Switches: Cooper/Arrow Hart #AH1221L; Hubbell #HBL1221L; Leviton #1221-2L; Pass & Seymour #PS20AC1-L.

B. Momentary Three Position Switches:

1. Manufacturer: Cooper/Arrow Hart #1995; Hubbell #HBL1557; Leviton #1257; Pass & Seymour #1251.
- C. Single Pole Double Throw (SPDT)-Center Off Switches:
1. Manufacturer: Cooper/Arrow Hart #2225; Hubbell #HBL1385; Leviton #1285; Pass & Seymour #1225.
- D. Pilot Light Type: Lighted handle (when load is on) meeting specifications of part A above.
- E. Locator Type: Lighted handle (when load is off) meeting specifications of part A above.
- F. Colors: Colors for all switches shall be:
1. As selected by the Architect for all switches. Note that different colors may be selected by the Architect for different areas of this project.
 2. Ivory for all switches.

PART 3 - EXECUTION

3.1 INSTALLATION

- A. General Requirements:
1. Install devices and assemblies level and secure. Unless otherwise indicated, mount flush, with long dimension vertical.
 2. Protect devices and assemblies during painting.
 3. Install wall plates when painting is complete.
- B. Back and Side Wired Devices: Only side wiring will be permitted for lighting switches and receptacles that are designed to be suitable for back and side wiring. Back wiring of these devices will not be permitted.
- C. Lighting Switch Requirements:
1. Install wall switches with OFF position down.
 2. Group adjacent switches under single, multi-gang wall plates.
 3. Verify all door swings; install switches on the lock side of doors.
- D. Receptacle Requirements:
1. Install grounding terminal of receptacles on top.
 2. Install specific-use receptacles at heights shown on Drawings or as required by equipment shop drawings.
 3. Install Tamper/Weather Resistant Ground Fault Interrupter (GFCI) Duplex Receptacles for all exterior and wet location locations.
- E. Provide momentary light switches for control of mechanically held relays, unless specifically noted otherwise.

3.2 CONNECTIONS

- A. Connect wiring device grounding terminal to branch-circuit equipment grounding conductor.
- B. Tighten electrical connectors and terminals according to manufacturer's published torque-tightening values. If manufacturer's torque values are not indicated, use those specified in UL 486A and UL 486B.

3.3 FIELD QUALITY CONTROL

- A. Test wiring devices for proper polarity and ground continuity. Operate each device at least six times.
- B. Test GFCI operation with both local and remote fault simulations according to manufacturer's written instructions.
- C. Replace damaged or defective components.

3.4 IDENTIFICATION

- A. Comply with Division 26 Section "Electrical Identification."

3.5 CLEANING

- A. Internally clean devices, device outlet boxes, and enclosures. Replace stained or improperly painted wall plates or devices.

END OF SECTION 262726

SECTION 264113 - LIGHTNING PROTECTION FOR STRUCTURES

PART 1 - GENERAL

1.1 RELATED DOCUMENTS

- A. Drawings and general provisions of the Contract, including General and Supplementary Conditions and Division 01 Specification Sections, apply to this Section.

1.2 SUMMARY

- A. Section includes lightning protection system for ordinary structures.
- B. Contractor is responsible for furnishing and installing a complete lightning protection system to meet UL requirements and NFPA standards indicated herein and be so labelled and certified.

1.3 ACTION SUBMITTALS

- A. Product Data: For each type of product.
- B. Shop Drawings:
 - 1. Include layouts of the lightning protection system, with details of the components to be used in the installation.
 - 2. Include raceway locations needed for the installation of conductors.
 - 3. Details of air terminals, ground rods, ground rings, conductor supports, splices, and terminations, including concealment requirements.
 - 4. Include roof attachment details, coordinated with roof installation and Warranty requirements.
 - 5. Calculations required by NFPA 780 for bonding of metal bodies.

1.4 INFORMATIONAL SUBMITTALS

- A. Coordination Drawings: Lightning protection system Shop Drawings, drawn to scale, on which the following items are shown and coordinated with each other, using input from installers of the items involved:
 - 1. Lightning protection cabling attachments to roofing systems and accessories.
 - 2. Lightning protection strike termination device attachment to roofing systems, coordinated with the roofing system manufacturer.
 - 3. Lightning protection system components penetrating roofing and moisture protection systems and system components, coordinated with the roofing system manufacturer.
- B. Qualification Data: For Installer.
- C. Product Certificates: For each type of roof adhesive for attaching the roof-mounted air terminal assemblies, approved by the roofing-material manufacturer.

- D. Field quality-control reports.

1.5 CLOSEOUT SUBMITTALS

- A. Maintenance Data: For lightning protection system to include in maintenance manuals.
 - 1. In addition to items specified in Division 01 Section "Operation and Maintenance Data," include the following:
 - a. Dimensioned site plan showing dimensioned route of the ground loop conductor and the ground rod locations. Comply with requirements of Section 017839 "Project Record Documents."
 - b. A system testing and inspection record, listing the results of inspections and ground resistance tests, as recommended by NFPA 780, Annex D.
- B. Completion Certificate:
 - 1. UL Master Label Certificate.

1.6 QUALITY ASSURANCE

- A. Installer Qualifications: UL-listed installer, category OWAY.

PART 2 - PRODUCTS

2.1 MANUFACTURERS

- A. Acceptable Manufacturers:
 - 1. A-C Lightning Security, Inc.
 - 2. Automatic Lightning Protection.
 - 3. Capital Lightning Protection, Inc.
 - 4. Harger Lightning Protection, Inc.
 - 5. Heary Bros. Lightning Protection Co. Inc.
 - 6. Independent Protection Company, Inc.
 - 7. Robbins Lightning, Incorporated.
 - 8. Thompson Lightning Protection, Inc

2.2 PERFORMANCE REQUIREMENTS

- A. NFPA Lightning Protection Standard: Comply with NFPA 780 requirements for Class I buildings.
- B. UL Lightning Protection Standard: Comply with UL 96A requirements for Class I buildings.
- C. Lightning Protection Components, Devices, and Accessories: Listed and labeled by a qualified testing agency as complying with UL 96, and marked for intended location and application.

2.3 MATERIALS

A. Air Terminals:

1. Copper unless otherwise indicated.
2. 5/8-inch (16-mm) diameter by 12 inches (305 mm) [(450 mm) long.
3. Rounded tip.
4. Threaded base support.

B. Class 1 Main Conductors:

1. Stranded Copper: 57,400 circular mils in diameter.

C. Secondary Conductors:

1. Stranded Copper: 26,240 circular mils in diameter.

D. Ground Loop Conductor: Connect to building ground loop.

E. Ground Rods: Provided with building ground loop.

F. Conductor Splices and Connectors: Compression fittings that are installed with hydraulically operated tools, or exothermic welds, approved for use with the class type.

PART 3 - EXECUTION

3.1 INSTALLATION

A. Install lightning protection components and systems according to UL 96A.

B. Install conductors with direct paths from air terminals to ground connections. Avoid bends less than 90 degrees and 8 inches (203 mm) in radius and narrow loops.

C. Conceal conductors within normal view from exterior locations at grade within 200 feet (60 m) of building. Comply with requirements for concealed installations in UL 96A.

1. Roof penetrations required for down conductors and connections to structural-steel framework shall be made using listed through-roof fitting and connector assemblies with solid rods and appropriate roof flashings. Use materials approved by the roofing manufacturer for the purpose. Conform to the methods and materials required at roofing penetrations of the lightning protection components to ensure compatibility with the roofing specifications and warranty.
2. Install conduit where necessary to comply with conductor concealment requirements.
3. Air Terminals on Single-Ply Membrane Roofing: Comply with adhesive manufacturer's written instructions.

D. Ground Ring Electrode: The conductor shall be not less than the main-size lightning conductor.

3.2 CONNECTIONS

- A. Aboveground concealed connections, and connections in earth or concrete, shall be done by exothermic welds or by high-compression fittings listed for the purpose.
- B. Aboveground exposed connections shall be done using the following types of connectors, listed and labeled for the purpose: exothermic weld.
- C. Bonding Straps and Jumpers: Install in locations accessible for inspection and maintenance, except where routed through short lengths of conduit.
 - 1. Bonding to Structure: Bond straps directly to basic structure, taking care not to penetrate any adjacent parts.
 - 2. Bonding to Equipment Mounted on Vibration Isolation Hangers and Supports: Install bonding so vibration is not transmitted to rigidly mounted equipment.

3.3 CORROSION PROTECTION

- A. Do not combine materials that can form an electrolytic couple that will accelerate corrosion in the presence of moisture unless moisture is permanently excluded from junction of such materials.
- B. Use conductors with protective coatings where conditions would cause deterioration or corrosion of conductors.

3.4 FIELD QUALITY CONTROL

- A. Special Inspections: Engage a qualified special inspector to perform the following special inspections:
 - 1. Perform inspections as required to obtain a UL Master Label for system.
- B. Prepare test and inspection reports and certificates.

END OF SECTION 264113

SECTION 265100 - LIGHTING EQUIPMENT

PART 1 - GENERAL

1.1 RELATED DOCUMENTS

- A. Drawings and general provisions of the Contract, including General and Supplementary Conditions and Division 01 Specification Sections, apply to this Section.

1.2 SUMMARY

- A. This Section includes the following:

1. Light Emitting Diode (LED) Luminaires.
2. Lighting fixtures and components, general requirements.
3. Lighting fixture supports.

- B. Related Sections include the following:

1. Division 26 Section "Occupancy Sensor Lighting Controls" for low voltage occupancy sensors, low voltage switches, power/switch packs, and wall switch occupancy sensors.
2. Division 26 Section "Relay Lighting Control Systems" for relay panels, relays, digital switch stations, digital occupancy sensors, networking hardware, etc. of programmable relay based lighting control systems with data communications.
3. Division 26 Section "Architectural Lighting Control Systems" for dimming panels, dimming modules, dimming/relay controllers, digital control stations, digital occupancy sensors, daylighting control sensors, networking hardware, etc. of programmable dimming systems with data communications.
4. Division 26 Section "Exterior Lighting" for poles, standards, bases, accessories and general exterior lighting requirements.
5. Division 26 Section "Emergency Lighting Equipment" for emergency battery units, emergency fluorescent ballasts, emergency lighting units, exit signs, and related equipment.
6. Division 26 Section "Luminaire List" for luminaires (light fixtures).

1.3 DEFINITIONS

- A. Color-rendering index (CRI): The measure that a light source has on perceived color of objects and surfaces.
- B. Coefficient of utilization (CU): Ratio of luminous flux (lumens) calculated as received on the work plane to the total luminous flux (lumens) emitted by the lamp alone. The value is obtained from the luminaire manufacturer published data.
- C. Light Loss Factor (LLF): The ratio of illuminance for a given area to the value that would occur if lamps operated at their rated lumens and if no system variation or depreciation had occurred.

- D. Lamp Lumen Depreciation (LLD): The fractional loss of lamp lumens at rated operating conditions that progressively occurs during lamp operation. The value is obtained from lamp manufacturer published data.
- E. Luminaire Dirt Depreciation (LDD): The fractional loss of task illuminance due to luminaire dirt accumulation.
- F. Luminaire efficacy rating (LER): The ratio of luminous flux (lumens) emitted by a luminaire to that emitted by the lamp or lamps used therein.
- G. Luminaire (light fixture): A complete lighting unit consisting of a lamp or lamps and ballast(s) (when applicable) together with the parts designed to distribute the light, to position and protect the lamps, and to connect the lamps to the power supply.
- H. Luminaire (light fixture) LED: A complete lighting unit consisting of a light emitting diode (LED) chip or die mounted to a circuit board with thermal management and driver(s) (when applicable) together with the parts designed to distribute the light, to position and protect the lamps, and to connect the lamps to the power supply.
- I. Room cavity ratio (RCR): A number indicating room cavity proportions, calculated from the length, width and height.

1.4 SUBMITTALS

- A. Product Data: For each type of lighting fixture, arranged in order of fixture designation. Include data on features, accessories, finishes, and the following:
 - 1. Detailed product data and installation instructions for each type of luminaire, lamp, LED driver, and any other components that comprise the complete lighting installation.
 - 2. A catalog data sheet for each and every type of luminaire. Catalog cut sheet shall contain the following:
 - a. Complete photometric data certified by an independent testing laboratory including but not limited to:
 - 1) Luminous intensity distribution represented in graphical and tabular formats. Candlepower data shall be presented in 5 degree increments (0 degree, 5 degree, 10 degree, etc.). Data shall be presented for both up and down light, normal, parallel, and at 22.5 degree, 45 degree and 67.5 degree when light output is asymmetrical.
 - 2) Zonal summary stated numerically at 0-30 degrees, 0-40 degrees, 0-60 degrees, and 0-90 degrees. Where applicable data shall be provided for 90-120 degrees, 90-130 degrees and 90-180 degrees.
 - 3) Coefficients of uniformity in tabular form.
 - 4) Visual comfort probability in tabular form.
 - 5) Luminaire efficiency data when used in conjunction with the appropriate lamp and ballast or LED and driver combination.
 - 3. Luminaire dimensional data.
 - 4. Complete scaled factory construction drawings from the manufacturer for each and every custom luminaire.
 - 5. Detailed drawings and bill of materials for all accessories and mounting hardware.

6. Photometric data, in IESNA format, based on laboratory tests of each lighting fixture type, outfitted with lamps, light emitting diodes (LEDs), ballasts, drivers, and accessories identical to those indicated for the lighting fixture as applied in this Project. When requested, photometric .ies files for each luminaire shall be written to a compact disc and be provided to the engineer for evaluation.
- B. A catalog data sheet for each and every type of LED driver. Catalog cut sheet shall contain the following:
 1. Manufacturer and catalog model number.
 2. Complete technical data including input watts, dimming capabilities, and all other data required to determine compliance with the product requirements stated in this section.
- C. Shop Drawings: Show details of nonstandard or custom lighting fixtures. Indicate dimensions, weights, methods of field assembly, components, features, and accessories.
 1. Wiring Diagrams: Power and control wiring.
- D. Coordination Drawings: Reflected ceiling plan(s) and other details, drawn to scale, on which the following items are shown and coordinated with each other, based on input from installers of the items involved:
 1. Lighting fixtures.
 2. Suspended ceiling components.
 3. Structural members to which suspension systems for lighting fixtures will be attached.
 4. Other items in finished ceiling including the following:
 - a. Air outlets and inlets.
 - b. Speakers.
 - c. Sprinklers.
 - d. Smoke and fire detectors.
 - e. Occupancy sensors.
 - f. Access panels.
- E. Samples for Verification: The Engineer reserves the right to request an engineering sample product of each and every luminaire, lamp, ballast, driver, or other component comprising the complete lighting system for inspection. Samples submitted shall be in full compliance with the specifications. Each sample luminaire shall be furnished complete with the following when applicable:
 1. Accessories: Cords and plugs.
- F. Qualification Data: For agencies providing photometric data for lighting fixtures.
- G. Field quality-control test reports.
- H. Operation and Maintenance Data: For lighting equipment and fixtures to include in emergency, operation, and maintenance manuals.
- I. Warranties: Special warranties specified in this Section.

1.5 QUALITY ASSURANCE

- A. Luminaire Photometric Data Testing Laboratory Qualifications: Provided by an independent agency, with the experience and capability to conduct the testing indicated, that is an NRTL as defined by OSHA in 29 CFR 1910.7.
- B. Electrical Components, Devices, and Accessories: Listed and labeled as defined in NFPA 70, National Electrical Code (N.E.C.), Article 100, by a testing agency acceptable to authorities having jurisdiction, and marked for intended use.
- C. Comply with the applicable requirements of NFPA 70, National Electrical Code (N.E.C.).

1.6 COORDINATION

- A. Coordinate layout and installation of lighting fixtures and suspension system with other construction that penetrates ceilings or is supported by them, including HVAC equipment, fire-suppression system, and partition assemblies.

1.7 CASH ALLOWANCES

- A. General: Where so indicated under the respective luminaire or luminaire assembly specification in Division 26 Section "Luminaire List" or where shown on the Luminaire (Light Fixture) Schedule on the drawings, the contractor shall provide the specified luminaire under a cash allowance and shall purchase the specified luminaire. Where so shown, the cash allowance shall be provided "per unit" or "per assembly" for the quantities shown on the drawings.
- B. Items Included: The following items shall be included under the case allowance:
 - 1. The complete luminaire or luminaire assembly specified including the luminaire, pole, lamp or LED source, ballast or driver, anchor bolts, and accessories specified under the respective luminaire specification.
 - 2. Freight F.O.B. shipping point, freight paid by shipper.
 - 3. Manufacturer's submittal and shop drawings.
 - 4. Manufacturer's warranty.
 - 5. Applicable taxes.
- C. Items Excluded: The following items shall not be included under the cash allowance but shall be included in the Contractor's bid:
 - 1. Contractor's costs for unloading, handling, and storage at the project site.
 - 2. Contractor's costs for construction of concrete pole foundation for mounting and support of the luminaire assembly.
 - 3. Contractor's costs for branch circuitry conductors, raceways, boxes, supports, etc. required to install and connect the luminaire assembly.
 - 4. Contractor's costs for installation and labor of the luminaire or luminaire assembly in its respective location.
 - 5. Contractor's overhead costs and profit.
 - 6. Other expenses not contemplated or specifically noted to be provided for under the cash allowance.

D. Manufacturer's Representation: The cash allowances published are prices as quoted by the Manufacturer or Manufacturer's Authorized Representative:

1. Luminaire (Light Fixture) Type(s): **[Types from Schedule]**.
 - a. Company: **[Name of Agency or Manufacturer]**.
 - b. Address: **[Address Line 1]**.
[Address Line 2].
 - c. Telephone: **[Phone Number]**.
 - d. Mobile: **[Cell Phone Number]**.
 - e. Fax: **[Fax Number]**.
 - f. Contact: **[Contact Name]**.

1.8 WARRANTY

A. Special Warranty for Light Emitting Diode (LED) Luminaires: Manufacturer's standard form in which the manufacturer agrees to repair or replace LED luminaires, including LED arrays, drivers, etc., that fail in materials or workmanship within specified warranty period.

1. Warranty Period for Light Emitting Diode (LED) Luminaires: Five (5) years from date of Substantial Completion.

1.9 EXTRA MATERIALS

A. Furnish extra materials described below that match products installed and that are packaged with protective covering for storage and identified with labels describing contents.

1. LED Drivers: 1 for every 100 of each type and rating installed. Furnish at least one of each type.
2. Globes and Guards: 1 for every 20 of each type and rating installed. Furnish at least one of each type.

PART 2 - PRODUCTS

2.1 MANUFACTURERS

A. Acceptable manufacturers for respective products shall be as listed in respective Part 2 articles in this section.

2.2 LIGHTING FIXTURES AND COMPONENTS, GENERAL REQUIREMENTS

A. General: Provide all luminaires as specified in Division 26 Section "Luminaire List" or as shown on the Luminaire (Light Fixture) Schedule on the drawings. Each luminaire shall be furnished complete with all necessary components including but not limited to housing, lamps, lamp holders, light emitting diodes (LEDs), reflectors, ballasts, drivers, starters and wiring. Each luminaire shall be shipped complete with all components factory installed and assembled for a complete and operating unit.

B. All Luminaires:

1. Shall bear the Underwriter's Laboratories (U.L.) label. See the individual luminaire specifications in Division 26 Section "Luminaire List" for specific requirements such as "wet locations", etc.
2. Shall have all metal parts bonded for a common grounding connection.
3. Utilizing lamp ballast(s) or LED driver(s) shall be designed and constructed to minimize noise generated by driver(s).
4. Shall have doors secured utilizing concealed spring loaded cam latches except where specified otherwise in Division 26 Section "Luminaire List". Doors shall be smooth operating, free of light leakage under operating conditions, and designed to permit re-lamping without use of tools.
5. Shall be designed to prevent doors, frames, lenses, diffusers, and other components from falling accidentally during re-lamping and when secured in operating position.
6. Shall be provided complete with appropriate flanges, trims, and other parts as required for the respective ceiling types.
7. Shall have sheet metal components of steel, unless otherwise indicated, formed and supported to prevent warping and sagging.
8. Shall have metal parts free of burrs and sharp corners and edges.
9. Shall have all ferrous metal parts, except cadmium plated hardware, rust proofed by a five stage phosphate pre-painting hot process after fabrication.
10. Shall have all metal parts painted after fabrication.
11. Shall be manufactured to tight tolerances and have closed and tight fitting connections with no light leaks.
12. Constructed with aluminum housings shall have minimum 1/8 inch thick aluminum.
13. Shall be pre-wired unless specifically noted otherwise.
14. Shall have reflecting surfaces shall have minimum reflectance as follows, unless otherwise indicated:
 - a. White Surfaces: 85 percent.
 - b. Specular Surfaces: 83 percent.
 - c. Diffusing Specular Surfaces: 75 percent.
 - d. Laminated Silver Metallized Film: 90 percent.

C. Light Emitting Diode (LED) Luminaires shall:

1. Be furnished complete with all light emitting diodes (LEDs), electronic drivers, housing, reflectors, etc. for a complete and operating unit as specified in Division 26 Section "Luminaire List".
2. Be furnished complete with integral dimming driver capable of the dimming range specified for the respective luminaire as specified in Division 26 Section "Luminaire List". The dimming driver shall be entirely compatible with dimming switches, dimming systems, etc. as specified or shown on the drawings. Proof of compatibility shall be furnished with the submittals.
3. Shall provide a continuous light output. Fixture lumen output shall be in accordance with the specifications and shall not depreciate more than 20 percent after 10,000 hours of use. The rated lumen output for LED fixtures to operate in ambient temperature of -20 deg. C to 50 deg. C.
4. Be equipped with appropriate thermal management technology to ensure that operating temperatures do not exceed the limits established by the LED chip manufacturer. Fixtures shall be provided with thermal cutoff circuitry to prevent damage to the luminaire.
5. Have either signal based or power based control as follows:

- a. Signal Based Control: For LED systems with controllable attributes such as color and/or output, the communications protocol shall be in accordance with the respective luminaire specification and compatible with the system shown on the Contract Documents. For data communications driven systems, each fixture shall have the capability to set a unique address for the network through an on-board address setting device.
 - b. Power Based Control: Variable output LED fixtures that are dimmed by direct modification of the input power shall dim from 100%-10% unless specified otherwise in Division 26 Section "Luminaire List". LED fixtures shall dim with no flicker and shall be provided with circuitry to cease light output at the low end of the dimming range prior to flicker occurring. Means of control shall be as specified on the Contract Documents by conventional dimming equipment.
6. Have light color for color changing LED luminaires selectable through stand-alone modes on board the luminaire or through data communications.
 7. Have light color for white LED fixtures as specified in Division 26 Section "Luminaire List" for each respective luminaire. Color variation between each chip shall not exceed 100 deg. K. White LED luminaires shall utilize chip-integral or remote phosphor technology.
 8. Have all connections to fixtures reverse polarity protected and have high voltage protection.
 9. Be furnished with all power supply outputs either fuse protected or PTC-protected as per Class 2 U.L. listing. All fixtures will have built-in circuit protection.
 10. Have warranty for the complete unit as specified elsewhere in this Section.
 11. Comply with DOE "Energy Star" requirements for LED lighting.
 12. Be furnished complete with photometric reports certified by an approved DOE laboratory in accordance with IESNA LM-79.
 13. Be furnished complete with a lumen depreciation report from the manufacturer. The Lumen depreciation report shall support the LED chip manufacturer's IESNA LM-80 test data.
 14. Have the entire assembly U.L. listed.
- D. Exterior Location Luminaires:
1. Shall be furnished complete with hollow section, high compliance, extruded, silicon gasket as required by the respective luminaire specification for damp or wet location listing.
 2. Shall be compliant with full cutoff classification as defined in IESNA Standard RP-33-99 "Lighting for Exterior Environments".
- E. Luminaire Wiring:
1. Shall be suitable for connection to respective branch circuit.
 2. Shall be NEC Type SF-2 for 120 and 277 volt applications.
 3. Shall be a minimum of #18 AWG.
- F. Plastic Diffusers, Covers, and Globes:
1. Acrylic Lighting Diffusers: 100 percent virgin acrylic plastic. High resistance to yellowing and other changes due to aging, exposure to heat, and UV radiation.
 - a. Lens Thickness: At least 0.125 inch (3.175 mm) minimum unless different thickness is indicated.
 - b. UV stabilized.

2. Glass: Annealed crystal glass, unless otherwise indicated.

2.3 DRIVERS FOR LIGHT EMITTING DIODE (LED) FIXTURES

- A. Light Emitting Diode (LED) Drivers: Drivers shall be fully electronic such that the principal current to the LED is controlled by a semi-conductor device. Drivers shall be electronic dimming type where specifically noted on the drawings or in Division 26 Section "Luminaire List".

1. All electronic drivers and electronic dimming drivers for use with light emitting diode (LED) fixtures shall:

- a. Have the following electrical characteristics:

- 1) Input Voltage Range – 108V to 132V.
- 2) Minimum Efficiency – 80%.
- 3) Output Current Regulation Range - +/- 5%A.
- 4) Total Harmonic Distortion (THD) – 20% maximum.
- 5) Power Factor – 0.9 minimum.
- 6) Crest Factor (LED Current) – 1.5 maximum.

- b. Have the following FCC Classifications:

- 1) FCC Class B for Conducted EMI.
- 2) FCC Class A for Radiated EMI.

- c. Have the following environmental ratings:

- 1) Operating Ambient Temperature: -40 deg. C./-40 deg. F. minimum; 60 deg. C./140 deg. F. maximum.
- 2) Case Temperature: 95 deg. C./203 deg. F. maximum.
- 3) Relative Humidity: 80% maximum.
- 4) Driver Life: 50,000 hours minimum.

2.4 LIGHTING FIXTURE SUPPORT COMPONENTS

- A. Comply with Division 26 Section "Hangers and Supports for Electrical Systems" for channel- and angle-iron supports and nonmetallic channel and angle supports.
- B. Single-Stem Hangers: 1/2-inch (13-mm) steel tubing with swivel ball fittings and ceiling canopy. Finish same as fixture.
- C. Twin-Stem Hangers: Two, 1/2-inch (13-mm) steel tubes with single canopy designed to mount a single fixture. Finish same as fixture.
- D. Wires: ASTM A 641/A 641M, Class 3, soft temper, zinc-coated steel, 12 gage (2.68 mm)
- E. Wires for Humid Spaces: ASTM A 580/A 580M, Composition 302 or 304, annealed stainless steel, 12 gage (2.68 mm).

- F. Rod Hangers: 3/16-inch (5-mm) minimum diameter, cadmium-plated, threaded steel rod.
- G. Hook Hangers: Integrated assembly matched to fixture and line voltage and equipped with threaded attachment, cord, and locking-type plug.

PART 3 - EXECUTION

3.1 INSTALLATION

A. General:

1. Lighting fixtures: Set level, plumb, and square with ceilings and walls. Install lamps in each fixture.
2. All luminaires shall be installed and adjusted in accordance with the manufacturer's written directions.
3. All luminaires shall be clean and in first class condition prior to acceptance by the owner.
4. All luminaire lenses, diffusers, louvers, etc. shall be handled with clean white gloves during installation and cleaning.
5. Recessed luminaires shall be secured to suspended ceiling system framing members. Provide clips or hangers specifically designed for support of the respective type of recessed luminaire. Specific supports requirements shall be as follows:
 - a. Lay-in Fluorescent Luminaires: Minimum of four (4) clips per luminaire (one (1) clip per corner), Equal to Caddy or Tenimon. Bend out tabs will not be acceptable.
 - b. Each luminaire shall be secured utilizing four (4) safety wires from the luminaire housing to the building structure. The safety wires shall be No. 12 gauge galvanized carbon steel hanger wires, pre-stretched with Class I coating.
 - c. Install a minimum of four ceiling support system wires for each fixture. Locate not more than 6 inches (150 mm) from lighting fixture corners.
 - d. Recessed Downlights: Bar suspension type hangers.
 - e. All Other Luminaires: Means as cited in NEC 410.16.
6. Surface mounted luminaires shall be secured to building structure utilizing appropriate anchors, hangers, straps, etc. specifically designed for support of the respective type of luminaire. Specific support requirements shall be as follows:
 - a. Surface mounted luminaires installed on a lay-in grid type ceiling system shall be secured utilizing independent support clips with four (4) No. 12 gauge pre-stretched galvanized carbon steel hanger wires from clip to the building structure above the ceiling. Clips shall be equal to Caddy "IDS" Series.
7. Each luminaire shall be secured utilizing two (2) safety wires from the luminaire housing to the building structure. The safety wires shall be No. 12 gauge galvanized carbon steel hanger wires, pre-stretched with Class I coating.
8. Luminaire Circuit Connections:
 - a. Final connections to luminaires shall be made utilizing Flexible Metal Conduit (Type FMC) installed per the requirements of Division 26 Section "Raceways and Fittings". A continuously insulated green grounding conductor shall be furnished in each Flexible Metal Conduit.

- b. Flexible Metal Conduit to recessed lay-in fluorescent luminaires shall be of adequate length to reposition the luminaire to one side. The intent of this provision is to allow the area of the luminaire to act as an access to the space above the ceiling.

9. Suspended Lighting Fixture Support:

- a. Pendants and Rods: Where longer than 48 inches (1200 mm), brace to limit swinging.
- b. Stem-Mounted, Single-Unit Fixtures: Suspend with twin-stem hangers.
- c. Continuous Rows: Use tubing or stem for wiring at one point and tubing or rod for suspension for each unit length of fixture chassis, including one at each end.

B. Application Specific Installation:

1. Continuous Luminaire Installations:

- a. Luminaires shall be mounted in continuous lengths and patterns as shown on the drawings.
- b. Luminaire patterns shall be furnished with a fabricated corner piece where run continuously around inside or outside corners. Luminaire lenses and louvers shall be continuous with the luminaire and shall be mitered and/or fanned at corners or angles. Exposed housings shall have cast corner or angle piece as shown on the drawings or as required.
- c. Where a continuous run of luminaires terminates at a wall or fascia, the luminaire installation shall be continuous from wall to wall.
- d. Where a continuous run of luminaires does not terminate at a wall or fascia, an end plate with no visible fasteners or holes shall be provided.
- e. Quantity sizes of lamps shall be furnished as required to completely fill the continuous luminaire installation with lamps. Lamps shall be staggered as required to eliminate socket

2. Adjust aimable lighting fixtures to provide required light intensities.

3. Aircraft Cable Suspended Luminaires:

- a. Provide complete with the required number of cable feed drops for each continuous run of suspended fixture including all switch or dim legs, emergency circuits feeds, etc.
- b. The feed points shall be as designed by the fixture manufacturer as required for the fixture to hang properly at the elevations indicated on the drawings.

3.2 FIELD QUALITY CONTROL

- A. Prepare a written report of tests, inspections, observations, and verifications indicating and interpreting results. If adjustments are made to lighting system, retest to demonstrate compliance with standards.

END OF SECTION 265100

SECTION 265113 – LUMINAIRE LIST

PART 1 - GENERAL

1.1 RELATED DOCUMENTS

- A. Drawings and general provisions of the Contract, including General and Supplementary Conditions and Division 01 Specification Sections, apply to this Section.

1.2 SUMMARY

- A. This Section includes the following:

- 1. Interior lighting luminaires.
- 2. Exterior lighting building mounted luminaires.
- 3. Exit Signs

- B. Related Sections include the following:

- 1. Division 26 Section "Lighting Equipment" for LEDs, lamps, electronic drivers, ballasts, accessories and mounting requirements.
- 2. Division 26 Section "Exterior Lighting" for poles, standards, bases, accessories and general exterior lighting requirements.

- C. DEFINITIONS

- 1. Luminaire (light fixture): A complete lighting unit consisting of a lamp or lamps and ballast(s) (when applicable) together with the parts designed to distribute the light, to position and protect the lamps, and to connect the lamps to the power supply.

1.3 SUBMITTALS

- A. Submittals shall be provided in accordance with the conditions of contract and Division 26 Section "Lighting Equipment".

1.4 PRODUCT SAMPLES

- A. The Engineer reserves the right to request an engineering sample product of each and every luminaire for inspection. Samples submitted shall be in full compliance with the specifications including but not limited to construction, design, visual appearance, and performance. The manufacturer shall have previously built the luminaire and the luminaire shall be a production item. The sample shall remain on file as comparison with the materials furnished on the project. Materials not equal to the approved sample will be rejected.

PART 2 - PRODUCTS

2.1 MANUFACTURERS

- A. Design Basis Manufacturer: Where listed in each respective luminaire specification, the "Design Basis Manufacturer" model series number shall serve to indicate the level of quality and minimum requirements for the luminaire to be furnished.
- B. Acceptable Manufacturers: Where acceptable manufacturers are listed in each respective luminaire specification, this shall be interpreted to mean that luminaires by the listed manufacturers will be acceptable as equals to the "Design Basis Manufacturer" luminaire provided that the manufacturer demonstrates full compliance with all of the requirements contained in these specifications.

2.2 LUMINAIRE LIST:

- A. Refer to Luminaire (Light Fixture) Schedule on Sheets E801 for all luminaire (light fixture) specifications

PART 3 - EXECUTION

A. GENERAL FIXTURE INSTALLATION

- 1. Luminaires shall be installed in accordance with the manufacturer's recommendations and the provisions of Division 26 Section "Lighting Equipment" and Division 26 Section "Emergency Lighting Equipment".

END OF SECTION 265113

SECTION 270500 - COMMUNICATIONS

PART 1 -GENERAL

1.1 Scope of work

- A. The Contractor is held responsible to be familiar with the provisions contained herein and with other Sections of this Specification as applicable to the completion of the installation.
- B. Work covered by this Section shall consist of furnishing labor, equipment, supplies, materials, and testing unless otherwise specified, and in performing the following operations recognized as necessary for the installation, termination, and labeling of all telecommunications infrastructure as described on the Drawings and/or required by these specifications.

1.2 Intent of the drawings and specifications

- A. These Specifications, together with the Drawings accompanying them, are intended to depict the installation requirements necessary to support this Project.
- B. Contractor shall furnish materials shown and/or called for on the Drawings but not mentioned in the Specifications, or vice versa, that are necessary for the installation and support of the described work, whether or not specifically called for in both.
- C. Contractor shall provide incidental equipment and materials required for the completion of systems included in this contract whether or not specified or shown on the Drawings.

1.3 Communication

- A. It is Purdue's expectation that the A/E of Record will work jointly with Purdue's Telecommunication representatives to address specific technical issues and Owner requirements.
- B. All questions, deviations, comments concerning guideline(s) interpretation, content, and/or use must be submitted in writing to the Project Manager for approval.
- C. No deviations from these guidelines shall be incorporated into the project without written approval from the Project Manager and Purdue Telecommunications representative.

PART 2 - PRODUCTS

2.1 All materials shall conform to the current applicable industry standards including, but not limited to:

- NEMA (National Electrical Manufacturers' Association)
- ANSI (American National Standards Institute)
- ASTM (American Society for Testing and Materials)
- ICEA (Insulated Cable Engineers Association)
- IEEE (Institute of Electrical and Electronic Engineers)
- NEC (National Electric Code)
- NESC (National Electrical Safety Code)

- 2.2 In addition, all Material shall be Underwriters Laboratories Listed unless otherwise indicated.
- 2.3 All products must be new.
- 2.4 Ceiling Loudspeakers for A/V System: Coaxial loudspeaker with 6.5" low frequency driver and a 3/4" high frequency driver. Frequency response of 65 Hz to 22 kHz with a 111 degree dispersion angle. Loudspeaker shall have a power rating of 65 Watts continuous. Loudspeaker shall be provided with a 70/100 Volt matching transformer, 8" deep back can and white front grille. Provide; Extron #SF-26CT.

PART 3 - EXECUTION

3.1 Telecommunications Installation

- A. Each Contractor shall be aware of work to be performed by other trades and take necessary steps to integrate and coordinate their work with other trades.
- B. The Contractor shall be responsible for furnishing all materials on the drawings or as specified herein for a complete telecommunications system.
- C. All telecommunications infrastructure shall be installed in an aesthetically pleasing fashion. All surface raceway in new buildings must be approved by a Purdue IT Infrastructure Services Representative.
- D. All telecommunications infrastructure shall be installed for optimal performance.
- E. All telecommunications infrastructure shall be installed and clearly labeled for easy moves, adds, and changes in the future.
- F. All work performed in occupied spaces shall be in a manner that allows the Owner to operate the existing facilities on a continuous basis.
- G. All user outages, including wireless access points, shall be submitted to the Purdue IT Infrastructure Services Department for approval (1) week before starting work that will affect user connectivity.
- H. Construction within new TRs must be substantially complete before the installation of telecommunications cabling. This includes but is not limited to the installation of plywood, cable tray, electrical outlets, light fixtures, sprinklers, ductwork, and grounding. All walls shall also be painted before the installation of telecommunications cabling. Note: Telecommunications Terminal Board shall not be painted.
- I. New TRs must be free from dust, dirt, and other foreign materials before the installation of any termination hardware or the termination of copper or fiber optic cables. The door to the telecommunication rooms must be installed and closed during termination.

3.2 Telecommunications Demolition

- A. Where the relocation of existing PICs is required and the new location will allow the existing cables to reach, the cables may be disconnected and removed back to the hallway raceway system for installation into the new PIC. Where existing cables will not reach, new cables shall be installed to the TR. The new PIC location shall be relabeled. This installation requires a retest of the voice and data cables.

- B. Where the removal of existing PICs is required, the contractor shall remove the PIC raceway, conduits, and cables back to the exterior of the TR. Contractor shall notify Purdue IT Infrastructure Services Representative at the time of removal. Owner will remove all items within the TRs. Removal of existing PICs requires as-built information from the contractor. Contractors are to supply a copy of the construction floor plan indicating where the PIC was removed and the labeling information on the PIC.
- C. PICs scheduled to be relocated shall be tested by the contractor prior to moving. This is to ensure the permanent link meets the category performance set forth by ANSI/TIA. The contractor is responsible for bringing failed tests to the attention of Purdue's IT Infrastructure Services department before proceeding. After reviewing and verifying the failed results, Purdue's IT Infrastructure Services department will discuss options for repair. Unless the failed result is over distance, the contractor shall re-terminate the jack and re-test to confirm that the termination was not the cause of the problem.
- D. Per the NEC, legacy voice and data systems not used within renovated areas shall be removed as part of the project. The Contractor is responsible to bring legacy systems within the proposed renovated areas not identified on the construction documents to the attention of the Purdue IT Infrastructure Services Department who will verify its usage. Note: Some legacy cabling still contains active circuits which must be verified and relocated in such a manner as to minimize customer disruption.

END OF SECTION 270500

SECTION 270528 - COMMUNICATIONS PATHWAYS (LABORATORY ONLY)

PART 1 - GENERAL

1.1 SCOPE OF WORK

- A. The Contractor is held responsible to be familiar with the provisions contained herein and with other Sections of this Specification as applicable to the completion of the installation.
- B. The work required under this section consists of Cable Tray System provided for “laboratory” conduits for telecommunications wiring, low voltage and inert gas piping included in this project. This section is not intended for building system telecommunications wiring or terminations to a PIC (Purdue Information Connection).
- A. Furnish and install Cable Tray System as specified in the Drawings and as specified herein, and in accordance with electrical specifications.

1.2 INTENT OF THE DRAWINGS AND SPECIFICATIONS

- A. These Specifications, together with the Drawings accompanying them, are intended to depict the installation requirements necessary to support this Project.
- B. Contractor shall furnish materials shown and/or called for on the Drawings but not mentioned in the Specifications, or vice versa, that are necessary for the installation and support of the described work, whether or not specifically called for in both.
- C. Contractor shall provide incidental equipment and materials required for the completion of systems included in this contract whether or not specified or shown on the Drawings.

1.3 COMMUNICATION

- A. It is Purdue’s expectation that the A/E of Record will work jointly with Purdue’s laboratory and project representatives to address specific technical issues and Owner requirements.
- B. All questions, deviations, comments concerning guideline(s) interpretation, content, and/or use must be submitted in writing to the Project Manager for approval.
- C. No deviations from these guidelines shall be incorporated into the project without written approval from the Project Manager and Architect’s representative.

1.4 ACTION SUBMITTALS

- A. Product Data: For each type of product.

1.5 CLOSEOUT SUBMITTALS

- A. Operation and Maintenance Data: Include in all manufacturers' packing-label warnings and instruction manuals.

PART 2 - PRODUCTS

2.1 PRODUCT REQUIREMENTS

- A. All raceway products containing telecommunications cabling shall be fiber ready to allow for minimum bend radius requirements.
- B. Provide wire basket cable tray of types and sizes indicated with connector assemblies, clamp assemblies, connector plates, splice plates and splice bars. Construct units with rounded edges and smooth surfaces; in compliance with applicable standards; and with the additional construction highlighted in Section 2.2
- C. All straight section longitudinal wires shall be constructed with a continuous top wire safety edge. Safety edge must be kinked and T-welded on all tray sizes.
- D. Wire basket cable tray shall be made of high strength steel wires and formed into a standard 2 inch by 4 inch wire mesh pattern with intersecting wires welded together. All mesh sections must have at least one bottom longitudinal wire along entire length of straight section.
- E. Wire basket cable tray sizes shall conform to the following nominal criteria:
 - 1. Straight sections shall be furnished in standard 118.3 inch lengths.
 - 2. Wire diameter shall be 0.196" (5mm) minimum on all mesh sections.
- F. In order for a system to be approved as an equipment ground conductor (EGC), all splicing assemblies shall be UL Classified or CSA approved as an EGC. When using powder coated wire mesh cable tray as an EGC, the paint must be completely removed at all contact points of splice/ground bolt attachments.

2.2 ACCEPTABLE MANUFACTURERS

- A. Basis of Design product is Eaton's B-Line Business - Flextray wire mesh basket tray.
- B. Subject to compliance with these specifications, cable tray systems to be installed shall be as manufactured by the following:
 - 1. Eaton's B-Line Business (formerly Cooper B-Line, Inc.)
 - 2. WBT Performance Cable Tray, nVent Caddy
 - 3. Cablofil, CF105/450BL (450WH), Legrand North America
 - 4. Or Owner approved equivalent.
- C. Product Description: NEMA VE 1, Class 20C ladder type tray.
- D. Material: Steel. ASTM A653SS, mill-galvanized before fabrication.
- E. Finish: Power Coat of manufacturer's standard colors, to match ceiling as indicated on drawings (white or black) with an average thickness of 1.2 mils to 3.0 mils.
- F. Inside Width: 12 inches (457 mm).
- G. Inside Depth: 4 inches (76.2 mm).

PART 3 - EXECUTION

3.1 GENERAL REQUIREMENTS

- A. Installation of new pathways shall not interfere with existing pathways in such a way that installation of new cables within the existing pathway is made more difficult.
- B. All trays should be supported using a minimum of ¼" All Threaded Rod (ATR).
- C. Special accessories shall be furnished as required to protect, support and install a wire basket cable tray system.
- D. Coordinate wire basket cable tray with other work as necessary to properly interface installation of wire basket cable tray with other work.
- E. Support trays and fasten to structure. Install supports at each connection point, at end of each run, and at other points to maintain spacing between supports of 5.0 feet (152.4 cm) maximum.

3.2 PATHWAY REQUIREMENTS FOR ENTRANCE CONDUITS

- A. If the entrance conduits exceeds the 180 degree of total bends limitation, an appropriate sized junction box or manhole is required. Access to the junction box from below shall be maintained.
- B. See attachment at end of this section for sizing of entrance conduit junction boxes.
- C. As-built drawings of entrance conduit path required to be submitted to Purdue IT Infrastructure Services before covered with soil.
- D. Install cable waterfalls on outside plant conduits entering the room from above where the incoming cable will transition to another raceway more than 6" vertically.

3.3 RISER CONDUITS

- A. Provide restorable fire stops inside and around conduits as recommended by UL1479 or ASTM E814 for all conduits penetrating fire-rated construction. Fire-rated construction to be verified with the Owner. All fire stopping penetrations must be labeled with the UL1479 or ASTM E814 reference number, dated, and signed by the technician who installed the fire stopping material.

3.4 HORIZONTAL DISTRIBUTION SYSTEM

- A. Cable Tray System
 - 1. Complete suspended cable basket system and necessary accessories shall be provided as shown on plans. Install entire cable basket system in accordance with manufacturer's minimum installation practices and all local governing codes.
 - 2. Coordinate installation of cable tray with other trades to allow a minimum of 12" above, 6" in front, and 3" below of clearance from piping, conduits, ductwork, etc.
 - 3. Submittal drawings, in the form of 8 1/2" x 11" catalog cut sheets, shall be provided for the following items: cable tray, fittings, accessories and load data.

4. Cable tray shall not be loaded beyond 60% of manufacturer's recommended load capacity.
5. Where a new cable basket distribution system encounters a wall, install sufficient 4" EMT sleeves or restorable fire stopping sleeves through the wall so cabling does not exceed 20% fill.
6. Install cable basket dropouts where more than 10 cables exit the distribution system.
7. Provide factory manufactured tee fittings and 90 degree fittings to maintain the tray performance characteristics. Utilize factory splice connectors to maintain the tray ground integrity.

B. Sleeves

1. Install a cable waterfall on all 4" conduit sleeves containing cables that transition more than 6" vertically from the sleeve down to another raceway (conduit or cable tray), unless otherwise noted.
2. Install nylon cable protectors at the leading conduit edge. These protectors would not be used on conduits where the cable waterfall is required (more than 6" of vertical drop).
3. Where cables must penetrate fire-rated walls between sections of skeletal conduit or cable tray sections, install sufficient 4" EMT sleeves or restorable fire stopping sleeves through the wall so cabling does not exceed 20% fill.

END OF SECTION 270528

SECTION 270553 – IDENTIFICATION FOR COMMUNICATIONS SYSTEMS

PART 1 GENERAL

1.01 Scope of work

- A. The Contractor is held responsible to be familiar with the provisions contained herein and with other Sections of this Specification as applicable to the completion of the installation.
- B. Work covered by this Section shall consist of furnishing labor, equipment, supplies, materials, and testing unless otherwise specified, and in performing the following operations recognized as necessary for the installation, termination, and labeling of all telecommunications infrastructure as described on the Drawings and/or required by these specifications.

1.02 Intent of the drawings and specifications

- A. These Specifications, together with the Drawings accompanying them, are intended to depict the installation requirements necessary to support this Project.
- B. Contractor shall furnish materials shown and/or called for on the Drawings but not mentioned in the Specifications, or vice versa, that are necessary for the installation and support of the described work, whether or not specifically called for in both.
- C. Contractor shall provide incidental equipment and materials required for the completion of systems included in this contract whether or not specified or shown on the Drawings.

1.03 Communication

- A. It is Purdue's expectation that the A/E of Record will work jointly with Purdue's Telecommunication representatives to address specific technical issues and Owner requirements.
- B. All questions, deviations, comments concerning guideline(s) interpretation, content, and/or use must be submitted in writing to the Project Manager for approval.
- C. No deviations from these guidelines shall be incorporated into the project without written approval from the Project Manager and Purdue Telecommunications representative.

PART 2 - PRODUCTS

2.01 Copper, Fiber, and Coax Riser Cable Labels in TRs

- A. Panduit #T050X000VPC-BK, 0.5" height, black lettering on white vinyl tape or Owner approved equal.

2.02 Copper, Fiber, and Coax Horizontal Cable Labels in TRs and behind faceplates

- A. Panduit #S100X150VAC, 1.0" wide x 1.5" length, white, print-on vinyl label or Owner approved equal.

2.03 Telephone 110-Block Labels in TRs

- A. Panduit #T038X000VPC-BK, 0.38" height, black lettering on white vinyl tape or Owner approved equal.

2.04 Faceplate Labels at the PIC Location

- A. Panduit #T038X000VPC-BK, 0.38" height, black lettering on white vinyl tape or Owner approved equal.

2.05 Patch Panel Labels in TRs

- A. Panduit #C061X030FJC, 0.61" wide x 0.30" height, one-port identifier, white, adhesive, polyolefin label or Owner approved equal.

PART 3 - EXECUTION

3.01 All horizontal cable labeling

- A. Cables shall be labeled with self-laminating marking tape, Panduit LS8 labeler or Owner approved equal labeling system.
 - 1. Size of letters and numbers shall be no less than 5/16" high by 1/8" wide.
- B. Horizontal voice and data cables at the BDF/IDF end cables shall be labeled with the information indicating termination of the opposite end of the cables.
 - 1. This shall include room location and jack designation.
 - 2. Place label on a visible part of cable within 12" of termination point for ease of identification after termination.
 - 3. All faceplate labeling shall be labeled left to right, top to bottom. A specific voice line shall always be labeled last in the series, unless a TV jack is present in which case the voice jack shall precede the TV jack.

Examples:

At the BDF/IDF end the 4-pair data cables for the 1st location in room 1137 would be labeled: 1137-A and 1137-B.

At the BDF/IDF end the 4-pair voice cable for the 1st location in room 1137 would be labeled: 1137-1

- C. Horizontal voice and data cables at the rooms cables shall be labeled 1-3" from termination with the following:

BDF/IDF TR room # - room # - Jack

- 1. Labels shall be visible by removing outlet cover plate.
- 2. For rooms with multiple outlet locations, identification would begin with the first receptacle to the left of the main entrance to the room and continuing clockwise around the room.

Examples:

1106-1137-A, 1106-1137-B, 1106-1137-1.

- D. Horizontal fiber cables at the BDF/IDF end shall be labeled with the information indicating termination of the opposite end of the cables.
1. Label shall include room location, fiber type ("S" for single-mode, "M" for multimode), and jack designation.
 2. Place label on a visible part of cable within 12" of termination point for ease of identification after termination.

Example: At the BDF/IDF end the 2-strand fiber cable for the first location in room 1137 would be labeled: 1137FOS-A with the "FO" indicating fiber optic cable and the "S" indicating single-mode fiber type.

Note: Fiber is labeled in pairs. (Blue and Orange strands would be treated as jack "A")

- E. Horizontal fiber cables at the rooms shall be labeled 4" from termination with the following:

BDF/IDF Telecom room # - room # FO(S or M)- Jack

Example:

1106-1137FOS-A, 1106-1137FOS-B.

- F. The label shall be visible by removing outlet cover plate.
- G. For rooms with multiple outlet locations, identification would begin with the first receptacle to the left of the main entrance to the room and continuing clockwise around the room.

Note: Fiber is labeled in pairs. (Blue and Orange strands would be treated as jack "A")

3.2 CATV cables

- A. CATV cables at the BDF/IDF shall be labeled at each end with the information indicating termination of the opposite end of the cables.
1. This shall include Cable system, room number, and cable number at opposite end.
 2. Place label on a visible part of cable 12" from end of cable for ease of identification after termination.

Example: MRDH has a BDF TR (room B009A) and IDF TR (room 285S). In this case room 285S distributes cable to room 236SE.

At the IDF end the horizontal cable from the room would be labeled: TV236SE-1.

- B. CATV cables at the rooms shall be labeled 4" from termination with the following:

BDF/IDF TR room # - TVroom # - Jack

Example: 285S-TV236SE-1. This shall be visible by removing outlet cover plate. For rooms with multiple outlet locations, identification would begin with the first receptacle to the left of the main entrance to the room and continuing clockwise around the room.

- 3.03 Room numbers used for PIC labeling shall only contain preceding zeros when an alpha character precedes the zeros.

Example: The PIC in room G002 would be labeled as G002-A/B/1

Example: The PIC in room 002 would be labeled as 2-A/B/1

3.04 Copper Riser Cable Labeling

- A. All riser cables shall be labeled with self-laminating marking tape, Panduit LS8 labeler, Brady TLS2200 labeler, or Owner approved equal labeling system.
- B. At the BDF and IDF, the copper riser cables shall be labeled at each end with the information indicating termination of the opposite end of the cables. This shall include building acronym and cable number and room location.
 1. Place label on a visible part of cable close to wiring block for ease of identification after termination.

Example: LYLE has a BDF TR, room B036, and an IDF TR, room 1006.

At the IDF end the 1st cable would be labeled: LYLE01-B036

At the BDF end the 1st cable would be labeled: LYLE01-1006

Note: Multiple riser cables between the BDF and IDFs are to be labeled as the same cable. e.g. Riser cables FS01 consists of (2) 100-pair cables (FS01, 1-100; FS01, 101-200). The cable label along with the pair count shall be labeled at each end of the wiring blocks.

3.05 Fiber Riser Cable Labeling

- A. All fiber optic riser cables shall be labeled at each end with the information indicating:
 - Building
 - Cable number
 - "FO" indicating a fiber and opposite end of cable.
 - "S" shall be used after the FO to indicate the use of single-mode fiber.
 - "M" shall be used after the FO to indicate the use of multi-mode fiber.
- B. Fiber type shall be labeled on the front of the fiber enclosure: SMF for single mode fiber; MMF for multimode fiber.
- C. Verify cable number with a Purdue IT Infrastructure Services Representative before labeling.

Example: In BDF room B098A, PHYS (Physics): PHYS01-FOM226 = the first 12-strand, multimode fiber riser cable to IDF room 226.

Example: In BDF room B098A, PHYS (Physics): PHYS01-FOS226 = the first 12-strand, single-mode fiber riser cable to IDF room 226.

3.06 Copper Riser 110-Block Labeling

- A. At the BDF and IDF, voice riser cables are terminated on their respective 110 blocks. Label only 1st and last pairs on each row of 110 blocks. Place cable number of riser cable on wiring block label in center of label.

3.07 Coax Riser Labeling (CATV)

- A. At the BDF and IDF, CATV riser cables shall be labeled at each end with the information indicating termination of the opposite end of the cables.

Example: At the IDF end in PHYS the 1st riser cable from the BDF would be labeled: TV01-B098A. At the BDF end the same cable would be labeled: TV01-226

3.08 Horizontal 110-Block Labeling (Critical Circuits)

- A. At the IDF, voice horizontal cables are terminated on their respective S110 blocks, with pairs on the blocks labeled in ascending room number order.
- B. All horizontal cables from same room should be terminated in sequential order on S110 blocks. Single 4-pair cables will be labeled with a room location and a jack designation. e.g. 1113-1 = a single voice jack in room 1113.
- C. Size of letters and numbers on labels for 110 wiring blocks shall be no less than 3/8" high.

3.09 Horizontal Patch Panel Labeling (Data)

- A. At the IDF, data horizontal cables are terminated on their respective patch panels, with jacks on the panels labeled in ascending room number order.
- B. All horizontal cables from same room should be terminated in sequential order at the patch panels.
- C. Size of letters and numbers on labels for patch panels shall be no less than 3/32" high by 1/16" wide.

Example: Single 4-pair cables will be labeled with a room location and a jack designation. e.g. 1137-A = a single data jack in room 1137.

3.10 Faceplate Labeling:

- A. At the rooms, the jacks will be labeled on the faceplates using the plastic insert to cover a printed identification tag with room number and proper jack designation as follows:

- B. Jack designation:

Data and VOIP = A through ZZ

Traditional Voice and Critical Circuits = 1 through 999.

Example:

1195-A = 1st data jack in room 1195

1195-B = 2nd data jack in room 1195

1195-AA = 27th data jack in room 1195

1195-AB = 28th data jack in room 1195.

Example:

1195-1 = 1st voice jack in room 1195

- C. Size of letters and numbers on labels for faceplates shall be no less than 3/8" high.
- D. At the rooms, the fiber jacks will be labeled on the faceplates using the plastic insert to cover a printed identification tag with room number and proper jack designation as follows:
- E. Jack designation:
Fiber = A through ZZ.

Example:

1195FOM-A = 1st multimode fiber jack in room 1195

1195FOM-B = 2nd multimode fiber jack in room 1195

1195FOM-AA = 27th multimode fiber jack in room 1195

1195FOM-AB = 28th multimode fiber jack in room 1195.

- 3.10.6 At the rooms, the coax jacks will be labeled on the faceplates using the plastic insert to cover a printed identification tag with room number and proper jack designation as follows:

Jack designation: TVrm#-1

Example:

TV236SE-1, 1st coax jack in room 236SE

3.11 Wall Mounted Fiber Box Labeling:

- A. All wall mounted fiber termination boxes shall be labeled with cable information on the inside of the fiber termination box door using manufacturer's label.

3.12 Equipment Frame Fiber Enclosure Labeling:

- A. All equipment frame fiber enclosures shall be labeled with cable information on the labeling panel below the enclosure using manufacturer's label.
- B. All frame labeling shall be coordinated with Purdue IT Infrastructure Services Representative prior to label placement

3.13 Wireless Access Point PICs:

- A. At the BDF/IDF end, the PICs installed for wireless access points (AP) data horizontal cables shall be labeled with the information indicating termination of the opposite end of the cables. This shall include room location and jack designation.
 - 1. Place label on a visible part of cable within 12" of termination point for ease of identification after termination.

Example: At the BDF/IDF end the 4-pair data cable for the WAP in room 1137 would be labeled: 1137AP-A and 1137AP-B

2. Size of letters and numbers shall be no less than 5/16" high by 1/8" wide.

B. At the rooms, the horizontal cables shall be labeled 4" from termination with the following:
BDF/IDF TR room # - room #AP - Jack

Note: The WAP PICs shall be labeled in each room starting from A/B. These PICs do not fall within the alphanumeric order of the normal PICs within the same room.

3.14 Special Labeling Installations

A. Contractor is responsible for contacting a Purdue IT Infrastructure Services Representative so that Purdue may provide instruction for labeling of elevator phones, fire alarms, ETS phones, Fiber Optic PICs, and other special circuits. Failure to contact a Purdue IT Infrastructure Services Representative to clarify labeling requirements may result in re-labeling at the cost of the contractor. Submission of a RFI is required to document that contact with a Purdue IT Infrastructure Services Representative was made.

B. Departmental cables where data is distribute within the same room and not from the BDF or IDF shall be labeled as follows:

1. At the remote equipment cabinet or enclosure, data horizontal cables are terminated on their respective patch panels, with jacks on the panels labeled in alphabetic order.
2. At the outlets, identification would begin with the first receptacle to the left of the main entrance to the room and continuing clockwise around the room.

Example: Single 4-pair cable will be labeled with a jack designation. DPT-A = a single data jack within the room. DPT-B = next jack within the room. Place label on visible part of the cable within 4" of the termination.

C. Departmental cables shall be labeled differently than cables distributed from the telecom room so they can easily be identified. Contact a Purdue IT Infrastructure Services Representative for special labeling and patch panel termination instructions at least 48 hours prior to the start of labeling.

D. Above Ceiling PICs for applications other than wireless access points which are located above 6' AFF shall be labeled as room #AC - Jack and room # - Jack

Example: At the BDF/IDF end the 4-pair data cable for the above ceiling data PIC in room 1137 would be labeled: 1137AC-A and 1137AC-B

Note: The above ceiling PICs shall be labeled in each room starting from A/B. These PICs do not fall within the alphanumeric order of the normal PICs within the same room.

3.15 PIC Re-labeling

A. Contractor is responsible for re-labeling all existing PICs that are moved or changed. This includes but is not limited to any PICs with rooms in which the room number has changed as part of the construction project. This also includes all termination hardware (110 blocks, patch panels, cables, and faceplates).

- B. All PIC relabeling shall follow the guidelines within this section.
- C. Existing identification shall be recorded and submitted with as-built documentation.
- D. Old labels on the cabling, faceplate, and/or patch panel shall be completely removed and replaced with new labels when a PIC requires re-labeling.



DIVISION: 270553
DRAWN/UPDATED BY: DJP
REVISION DATE: 03/10/2016

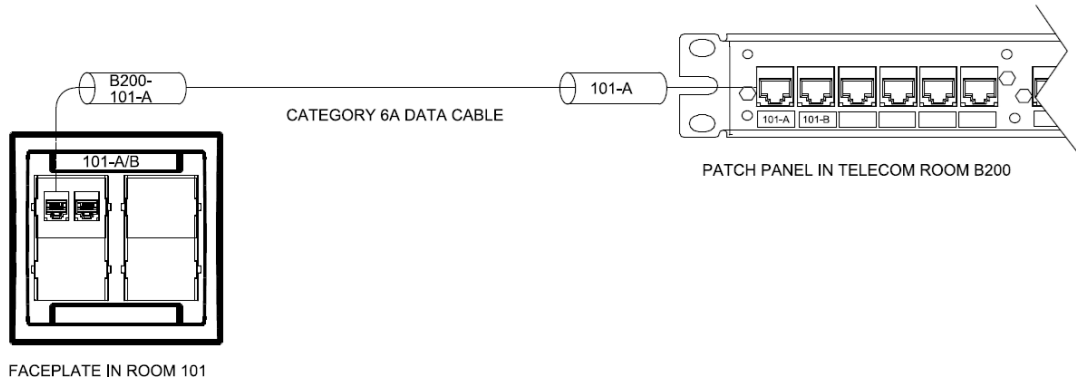

 TYPICAL PIC LABELING
NOT TO SCALE

PURDUE UNIVERSITY • INFORMATION TECHNOLOGY INFRASTRUCTURE SERVICES

END OF SECTION 270553

SECTION 271119 – TERMINATION BLOCKS AND PATCH PANELS

PART 1 - GENERAL

1.1 Scope of work

- A. The Contractor is held responsible to be familiar with the provisions contained herein and with other Sections of this Specification as applicable to the completion of the installation.
- B. Work covered by this Section shall consist of furnishing labor, equipment, supplies, materials, and testing unless otherwise specified, and in performing the following operations recognized as necessary for the installation, termination, and labeling of termination blocks and patch panels as described on the Drawings and/or required by these specifications.

1.2 Intent of the drawings and specifications

- A. These Specifications, together with the Drawings accompanying them, are intended to depict the installation requirements necessary to support this Project.
- B. Contractor shall furnish materials shown and/or called for on the Drawings but not mentioned in the Specifications, or vice versa, that are necessary for the installation and support of the described work, whether or not specifically called for in both.
- C. Contractor shall provide incidental equipment and materials required for the completion of systems included in this contract whether or not specified or shown on the Drawings.

1.3 Communication

- A. It is Purdue's expectation that the A/E of Record will work jointly with Purdue's Telecommunication representatives to address specific technical issues and Owner requirements.
- B. All questions, deviations, comments concerning guideline(s) interpretation, content, and/or use must be submitted in writing to the Project Manager for approval.
- C. No deviations from these guidelines shall be incorporated into the project without written approval from the Project Manager and Purdue Telecommunications representative.

PART 2 - PRODUCTS

2.1 Equipment Frames shall be owner-approved 19" wide x 7'-0" high, aluminum construction powder coated black. Refer to Section 27 COMMUNICATION 1106.

2.2 Panduit 110 Blocks

- A. 110 Termination Blocks for Copper Riser Cables
 - Panduit #P110KB1005Y, field termination kit
 - Field termination kit includes wiring block, (20) 5-pair connector blocks, and labels.

- Panduit #P110BW100-X, 110 Block
- Panduit #P110CB5-XY, 5-pair 110 Connecting Block
- Panduit #P110LH, Designation Label Holder
- Panduit #DSL110, 110 Designation Labels

B. 110 Termination Blocks for Copper Horizontal Cables

- Panduit #P110KB1004Y, field termination kit
 - Field termination kit includes wiring block, (20) 4-pair connector blocks, (4) 5-pair connector block, and labels.
- Panduit #P110BW100-X, 110 Block
- Panduit #P110CB4-XY, 4-pair 110 Connecting Block
- Panduit #P110LH, Designation Label Holder
- Panduit #DSL110, 110 Designation Labels

2.3 Panduit Patch Panels

- Panduit #CPPA24FMWBLY, Category 6a, 24-port angled modular patch panel, with TG style mini-com jacks and rear-mounted faceplates

2.4 Wall Mount Bracket for Patch Panels

- Panduit #WBH3 or owner-approved hinged 3 RU and 6" deep minimum wall mounted bracket

2.5 Wire Management for Equipment Frames

- A. Horizontal Wire Management for copper is not required between Category 6a angled patch panels
- B. One Panduit #NMF4 Horizontal Wire Management shall be installed between 23RU (42" AFF) and 26RU on equipment frames
- C. Vertical Wire Management
- Panduit #NRV12 wire management shall be installed on either side of equipment frames in buildings utilizing Category 6a cabling.
 - In buildings lacking sufficient space, size deviations must be approved prior to installation by Purdue Information Technology Infrastructure Services personnel.
 - Panduit #NRD12B1 – 45RU dual hinged 12" door
 - In buildings lacking sufficient space, size deviations must be approved prior to installation by Purdue Information Technology Infrastructure Services personnel.
 - Panduit #WMPVCBE wire management center mount brackets between adjacent frames
- D. One Panduit #SRB19MDBL Strain Relief Bar shall be installed on the back (termination side) of the Equipment Frame starting at the uppermost patch panel and on every other patch panel underneath to relieve cable strain. Utilize hook and loop cable ties (Velcro® or owner-approved equivalent) to relieve cable strain.

2.6 Telecommunication Wire Management

- Panduit #CMVDR1, Plastic D-rings for Owner furnished cross connects.
- Panduit #CMVDR2, Plastic D-rings for Vertical and Horizontal Cable Management on plywood.

2.7 Fiber Enclosures

A. Wall Mounted Fiber Enclosures

- Corning Cable Systems #WCH-02P fiber enclosure
- Corning #CCH-CP12-A9, 12-port duplex LC style single-mode panels

B. Frame Mounted Fiber Enclosures for Riser and Horizontal Fiber

- Corning Cable Systems #CCH-02U fiber enclosure for 2-48 fiber strands
- Corning Cable Systems #CCH-03U fiber enclosure for 49-72 fiber strands
- Corning Cable Systems #CCH-04U fiber enclosure for 73-144 fiber strands
- Corning #CCH-CP12-A9, 12-port duplex LC style single-mode panels

C. Provide the appropriate quantity of 12-port panels to match the fiber strand count that will be supplied to each fiber enclosure.

PART 3 - EXECUTION

3.1 110-Block Installation

- A. The telecommunications rooms shall contain wiring blocks as required to terminate all incoming pairs and all outgoing pairs.
- B. Locate telephone wiring blocks on fire-treated plywood backboards as specified on the Drawings or as specified herein.
- C. BDF block labeling for riser cables shall designate the corresponding destination IDF wiring block.
- D. BDF/IDF terminal boards shall be equipped with "D" rings for horizontal and vertical wire management as directed by Purdue's IT Infrastructure Services Representative.
- E. Horizontally separate 110 blocks 12" apart for horizontal cable by floor. Start 110 blocks 5'-6" AFF. In the BDF, horizontally separate 110 blocks 12" away from entrance protectors. If entrance protectors are not installed, leave enough space as specified above (protector dimension= 14.75" width by 11" height). See 3.01 Attachment #1.
- F. Horizontal cables shall enter new 110 blocks from the left side. Cables shall not be routed behind 110 blocks. In cases where existing cables have been routed behind the 110 blocks, contact Purdue's IT Infrastructure Services Representative before proceeding with new cable installation.
- G. Telecommunication rooms feeding multiple floors
 1. Install 110 blocks for each floor in a separate vertical row with each row separated 12" apart horizontally. See 3.01 Attachment #1.
- H. When terminating cabling on new 110 blocks, PICs in the same room shall be punched down on adjacent 4-pair connecting blocks and the rooms shall be in numerical order.
- I. When terminating new cabling on existing 110 blocks, PICs in the same room shall be punched down on adjacent 4-pair connecting blocks and the rooms shall be in as close to numerical order as practical.

3.2 Patch Panel Installation

- A. Each telecom room shall contain patch panels as required to terminate all pairs on its respective floor area or floors served.
- B. Locate data patch panels in 19" equipment frames as specified on the drawings or as specified herein.
- C. Patch panels to be mounted in equipment frames no higher than 6'-0" A.F.F. and no lower than 3'-6" (42") A.F.F. (39RU – 25RU)
- D. Where additional equipment frames are required, separate the frames using one 12" vertical cable management device.
- E. Include vertical cable management on both sides of every equipment frame. Multiple frames shall be separated by a 12" vertical cable management device.
- F. Patch panels for buildings with a telecom room too small for an equipment frame shall utilize hinged, wall mountable brackets to mount the horizontal wire management and patch panels. Coordinate with Purdue Information Technology Infrastructure Representative for placement information.
- G. Each category of cabling shall have its own patch panel and corresponding jacks

3.3 Fiber Panel Installation

- A. Wall Mounted Installations
 1. Mount fiber enclosures on the wall adjacent or next to equipment frame where applicable. Verify Corning WCH box use and location with Purdue's IT Infrastructure Services Representative unless otherwise shown on the drawings.
 2. Enclosures for multimode fiber to be complete with multimode LC connector panels.
 3. Enclosures for single-mode fiber to be complete with single-mode LC connector panels.
 4. Wall mounted fiber enclosure installations are only to be used when the telecommunications room does not have adequate space for an equipment frame. Consult with Purdue's IT Infrastructure Services Representative before installing wall mounted fiber enclosures.
- B. Equipment Frame Installations
 1. Install frame mounted fiber enclosures at the top of the equipment frames where applicable. Verify frame mounted fiber enclosure use and location with Purdue's IT Infrastructure Services Representative unless otherwise shown on the drawings.
 2. Install horizontal fiber management panel for every frame mounted fiber enclosure used. Alternate fiber enclosure panels with the fiber management panels.
 3. Allow 8 inches at the top of the mountable portion of the BDF equipment frame when outside plant fiber has not yet been installed.
 4. In the BDF, install:
 - One (1) Corning Cable Systems #CCH-02U for buildings containing (1-2) IDFs.
 - One (1) Corning Cable Systems #CCH-04U for buildings containing (3-6) IDFs.
 - Additional CCH-04U housings would be needed for buildings containing over six IDFs.
 5. In the IDFs, install:
 - One (1) Corning Cable Systems #CCH-02U for single-mode fiber terminations
 - a. Enclosures for single-mode fiber to utilize
 - One (1) Corning 12-port duplex LC style SM panels per 12-strand single-mode fiber.

6. Purdue's IT Infrastructure Services Representative shall provide location for mounting enclosures if not shown on drawings.
7. Typically Multi-mode fiber and Single-mode fiber is always terminated in a frame mounted CCH panel in every telecommunications room unless an equipment frame is not present within the room.

TYPICAL BDF LAYOUT

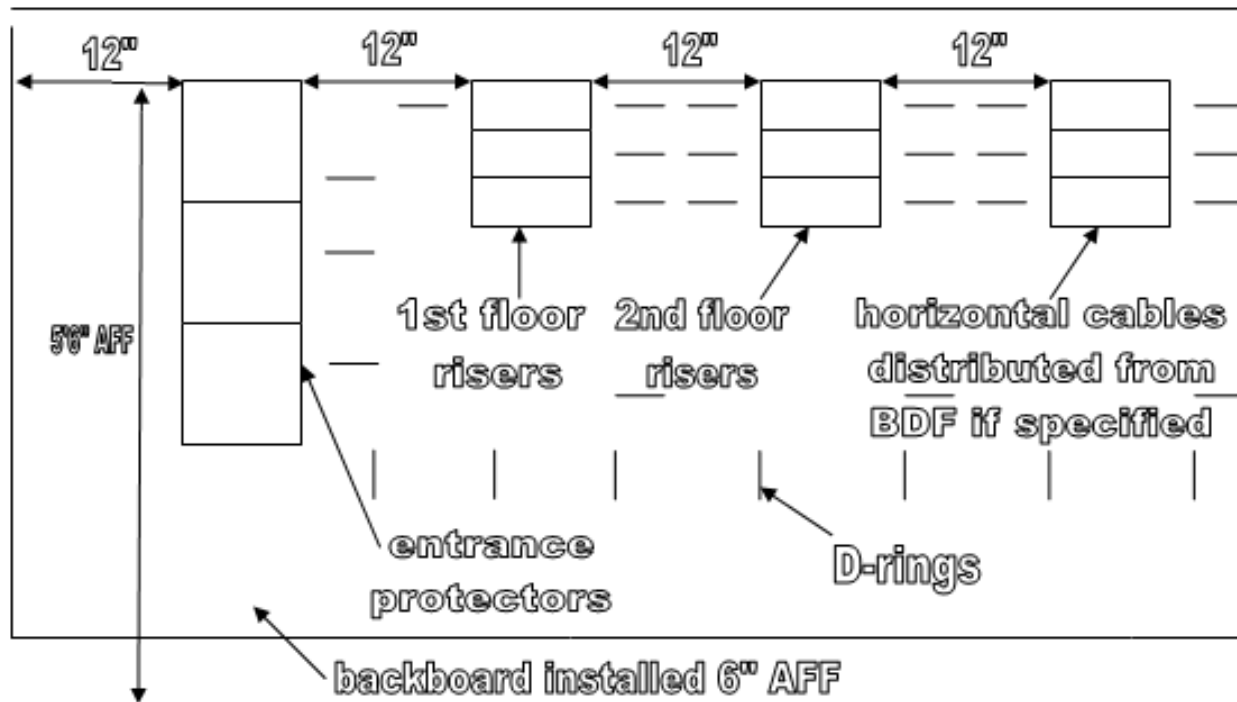

TYPICAL IDF LAYOUT

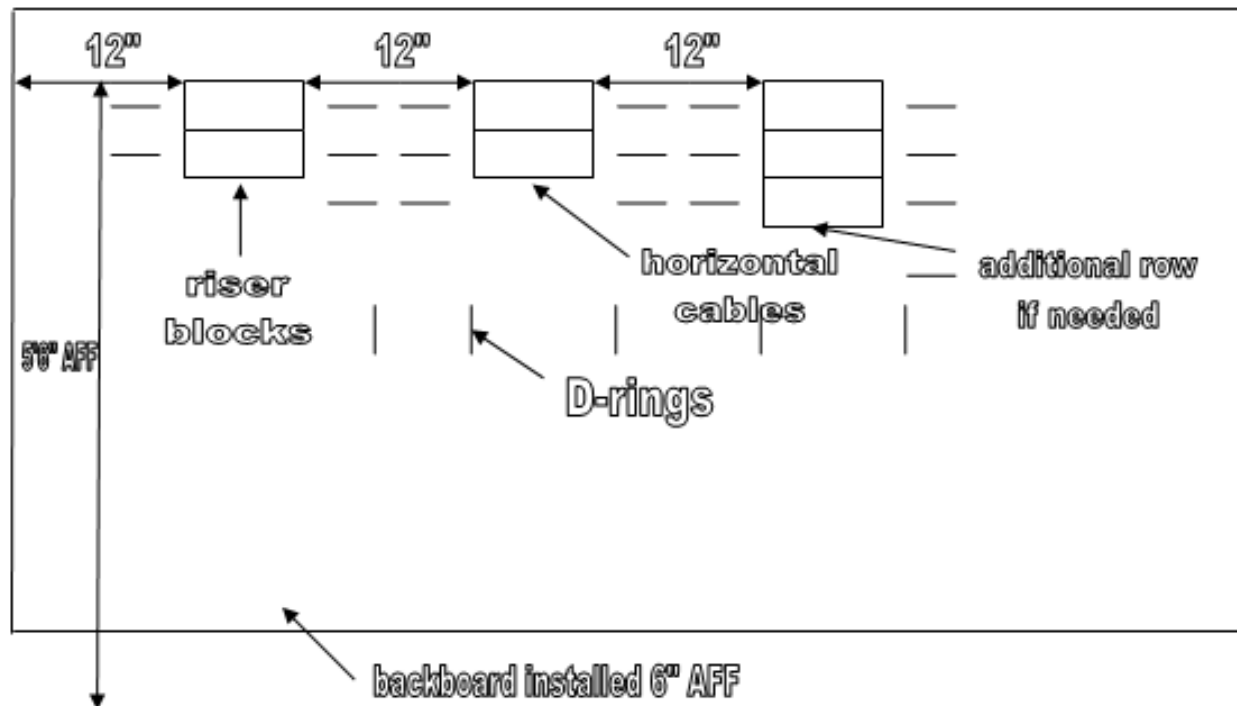

SECTION 271513 – COPPER HORIZONTAL CABLING

PART 1 - GENERAL

1.01 Scope of work

- A. Work covered by this Section shall consist of furnishing labor, equipment, supplies, materials, and testing unless otherwise specified, and in performing the following operations recognized as necessary for the installation, termination, and labeling of copper horizontal cabling infrastructure as described on the Drawings and/or required by these specifications.

PART 2 - PRODUCTS

2.01 General

- A. The materials and products specified herein reflect the minimum acceptable standards of fabrication and manufacture. All materials and products supplied by the Contractor and specified herein are to be new, unused, of first quality and in original packaging or shipping containers or as shown on drawings and described in Item 3.01.
- B. New buildings and major renovations will be treated differently than existing buildings due to advances in cable transport technologies. Contact Purdue Information Technology Telecommunications Department Representative for approval of cabling systems before installation.

2.02 Data and VOIP Cabling

- A. All new buildings and major renovations on the Purdue West Lafayette Campus require Category 6a cabling:
 - 1. Owner-approved single 4-pair, category 6A, unshielded twisted pairs, 23 gauge, bare copper, polyethylene insulated conductors, with overall violet/purple PVC flame retardant jacket, plenum rated.
 - 2. Cables shall be terminated on patch panels in equipment frames with violet/purple jacks on both ends of the permanent link termination
 - a. Approved manufacturer part numbers include:
 - i. Belden 10GXS13 Cat 6A cable item numbers: 10GXS13- 0071000 (1,000 feet)
 - ii. Berk-Tek LANmark-10G2 Plenum Cat 6a cable item number: 11085661
 - iii. CommScope Uniprise® Cat 6A item number: UN874041604/10 | CS44P VLT C6A 4/23 U/UTP RL 1KFT
 - iv. General Cable GenSPEED 10 Cat 6A item number: 7141825
 - v. Mohawk GigaLAN10 Cat 6A item number: M59154
 - vi. Superior Essex 10Gain Cat 6A item number: 6A-246-7B or 6A-272-7B

2.03 Special Circuit Cabling

- A. All new buildings and major renovations on the Purdue West Lafayette Campus require Category 6a cabling:
 - 1. Owner-approved single 4-pair, category 6A, unshielded twisted pairs, 23 gauge, bare copper, polyethylene insulated conductors, with overall violet/purple PVC flame retardant jacket, plenum rated.

2. Cables shall be terminated on S110 blocks in Telecom Rooms
 - a. Approved manufacturer part numbers include:
 - i. Belden 10GXS13 Cat 6A cable item numbers: 10GXS13- 0071000 (1,000 feet)
 - ii. Berk-Tek LANmark-10G2 Plenum Cat 6a cable item number: 11085661
 - iii. CommScope Uniprise® Cat 6A item number: UN874041604/10 | CS44P VLT C6A 4/23 U/UTP RL 1KFT
 - iv. General Cable GenSPEED 10 MTP Cat 6A item number: 7141825
 - v. Mohawk GigaLAN10 Cat 6A item number: M59154
 - vi. Superior Essex 10Gain Cat 6A item number: 6A-246-7B or 6A-272-7B

PART 3 - EXECUTION

3.01 Telecommunications Installation

A. General:

1. This Section describes the installation locations for the products and materials, as well as methods and Owner's Standards associated with the Telecommunications Installation portions of the Project. These Specifications, along with the drawings and other Owner supplied specifications shall be followed during the course of the installation.
2. The Contractor is required to be currently listed as either a BICSI Certified Installer or a registered Panduit Certified Installer and provide personnel for telecommunications installations who are verifiably certified.
3. The Contractor is instructed to coordinate his efforts with the other tradesmen who may be working within the same vicinity to avoid conflict and lost time.
4. The Contractor is required to supply all necessary tools, equipment, accessories, safety equipment, protective clothing, etc., as customary for the craft and necessary for the installation.
5. The Contractor shall verify space requirements and locations with Owner before starting cable installations and terminations.
6. The Contractor shall verify the category and jacket rating required with the Purdue IT Infrastructure Services Department before starting cable installation.
7. The Contractor shall verify existing cable fill in skeletal conduit, raceway or cable tray system before installation of additional cables so as not to exceed 40% cable fill. Contractor will be responsible for installation of additional skeletal conduit, raceway or cable tray where additional cables to be added will exceed the 40% cable fill.

3.02 Skeletal, Cable Tray, And Station Conduits

- A. Provide a nylon pull cord in each conduit to facilitate future installation of cables.
- B. Provide a nylon pull cord in each conduit and extended in raceway to openings for PIC faceplates to facilitate future installation of cables.
- C. Provide a nylon pull cord in each straight section of cable tray. Pull cord shall be continuous from each end of the straight section of tray.

3.03 Horizontal Copper Cabling

- A. The copper voice horizontal cabling will be terminated at the IDF or BDF on S110 type wiring blocks.

- B. The copper data horizontal cabling will be terminated at the IDF or BDF on patch panels as described herein. Where patch panels are mounted in equipment frames, equally distribute cables on each side, down the vertical wire management, and into the horizontal wire management so as not to exceed wire management fill.
- C. Horizontal cabling shall be terminated such that wire pair twists are maintained as closely as possible to the point of mechanical termination. (No greater than 0.5")
- D. Maximum strip length shall be 1.0" or less. Maintain cable sheath to leading edge of connector block.
- E. Contractor is responsible to obtain and follow installation instructions from the manufacturer for correct termination and wire management of cables on respective products.
- F. Owner to provide future cross-connect terminations to Campus switch.
- G. Horizontal cables shall be terminated in the telecom room serving that floor unless otherwise noted. Exceptions would include telecom rooms serving multiple floors.

3.04 Relocation And Removal Of Existing Telecommunication Outlets

- A. Where the relocation of existing PICs is required and the new location will allow the existing cables to reach, the cables may be disconnected and removed back to the hallway skeletal or raceway system for installation into the new PIC. Where existing cables will not reach, new cables shall be installed to the TR. The new PIC location shall be relabeled. This installation requires a retest of the voice and data cables.
- B. Where the removal of existing PICs is required, the contractor shall remove the PIC raceway, conduits, and cables back to the exterior of the TR. Contractor shall notify Owner's Representative at the time of removal. Owner will remove all items within the TRs. Removal of existing PICs requires as-built information from the contractor prior to removal. Contractors are to supply a copy of the construction floor plan indicating where the PIC was removed and the labeling information on the PIC to the Purdue IT Infrastructure Services Department.
- C. PICs scheduled to be relocated shall be tested by the contractor prior to moving. This is to ensure the permanent link meets the category performance set forth by ANSI/TIA. The contractor is responsible for bringing failed tests to the attention of Purdue IT Infrastructure Services Department before proceeding. After reviewing and verifying the failed results, Purdue IT Infrastructure Services Department will discuss options for repair.
- D. Per the NEC, cabling for legacy voice and data systems that will not be used within renovated areas shall be removed as part of the project. The Contractor is responsible to bring legacy systems within the proposed renovated areas not identified on the construction documents to the attention of the Purdue IT Infrastructure Services Department who will verify its usage. Note: Some legacy cabling still contains active circuits which must be verified and relocated in such a manner as to minimize customer disruption.

3.05 Wiring Configuration

- A. Wire all jacks according to ANSI/TIA/EIA T568-B configuration.

3.06 General Cable Installation

- A. Cable lengths within boxes shall be adequate to permit installation and removal of device for inspection without damage to cable or connections (minimum of 12”).
- B. Cable bends shall not be greater than that recommended by the manufacturer of the cable.
- C. Care shall be taken so as not to damage cable during the installation process and that manufacturer’s pull tension specification is not exceeded.
- D. Route cables so that no horizontal cable exceeds 90 meters between TR termination and device jack termination. Contact the Purdue IT Infrastructure Services Department if this is not probable with TR location.
- E. Provide a minimum 8’-0” and maximum 10’-0” of slack. Slack in the TRs to be contained on the cable tray so that the cables lay flat and do not cross over themselves (no coils). Smaller slack loops may be required in TR cabinets.
- F. Within TRs, cables shall be snugly wrapped using hook and loop (Velcro® or owner-approved equal) reusable cable ties, a minimum of every 3’-0” for cable organization. Hook and loop ties shall be tightened so as not to deform cable jackets and thus affect cable performance. Plastic cable tie wraps shall not be used.
- G. Hook and loop cable ties and tie wraps shall not be used in cable trays and skeletal systems outside of the TR.
- H. Cable fill in station conduits, skeletal conduits, raceway, and cable tray shall not exceed 40% cable fill.
- I. All telecom rooms must be free from dust, dirt, and other foreign materials before the installation of any termination hardware or the termination of copper or fiber optic cables. The door to the telecommunication rooms must be installed and closed during termination.
- J. Contractor is responsible for the protection of all telecommunications equipment in existing telecom rooms. Contractor shall contact the Purdue IT Infrastructure Services Department before starting any work in an existing telecom room that might cause dust and debris to harm network equipment.

3.07 Cable Testing

- A. A 20% verification by the Purdue IT Infrastructure Services Department of all horizontal voice and data cable tests will be performed. A 100% verification by the Purdue IT Infrastructure Services Department of all wireless access point installations will be performed. The contractor performing the telecommunications testing shall schedule a meeting with a Purdue IT Infrastructure Services Representative before the start of testing. Contractor may request Purdue personnel to accompany them in the testing of cables to ensure proper information entry into the Tester. If Purdue personnel accompany the Contractor on testing, verification testing shall not be required.
- B. The horizontal cabling consisting of single 4-pair cable runs for data and VOIP shall be tested for Category 6a compliance utilizing a Fluke DTX or Fluke DSX series tester. Test unit shall be set up using: 1) cat. 6a permanent link test, 2) actual cable # installed (e.g. CommScope #874010104). 3) Cable Test Results shall be submitted in Fluke Linkware (.flw) format on a CD at the end of the project. Purdue IT Infrastructure Services Department will expedite activation of service before substantial completion if test results are submitted electronically via email. Testing

required is 100%. The Purdue IT Infrastructure Services Department will perform random verification testing as part of acceptance of all copper voice cable testing.

- C. The horizontal cabling consisting of single 4-pair cable runs for special circuits shall be tested for Category 5e compliance utilizing a Fluke DTX or Fluke DSX series tester. Test unit shall be set up using: 1) cat. 5e permanent link test, 2) actual cable # installed (e.g. CommScope #874010104). 3) Cable Test Results shall be submitted in Fluke Linkware (.flw) format on a CD at the end of the project. Purdue IT Infrastructure Services Department will expedite activation of service before substantial completion if test results are submitted electronically via email. Testing required is 100%. The Purdue IT Infrastructure Services Department will perform random verification testing as part of acceptance of all copper data cable testing.

3.08 Equipment Installation And Cable Terminations

- A. All equipment shall be installed in a neat and workmanlike manner, arranged for convenient operation, testing and future maintenance.
- B. All paired cables shall be installed and terminated by technicians experienced in the termination of cables on connector blocks.
- C. The Contractor shall employ certified system installation technicians and have at least 5 years of experience in the installation of similar and equivalent systems.
- D. The Contractor shall supply verification of experience, for this type of work, to the Architect for approval before performing any work.

3.09 As Built Information

- A. Contractor shall provide as-built information along with all test result information to the Purdue IT Infrastructure Services Department.
- B. As-built information shall be in red-lined format on a copy of construction drawings. Indicate location of all PICs, skeletal and riser conduit routes, distribution cable trays, junction boxes, and all additions and deletions pertaining to telecommunications. Include correct PIC labeling next to all telecom symbols.
- C. If construction drawings are not utilized, Contractor shall provide all telecommunications location information on an accurate scaled floor plan.
- D. Contractor shall perform all labeling requirements and provide testing documentation for verification as described herein.
- E. Contractor shall submit cable records to reflect all moves, additions, and changes.
- F. Contractor shall provide floor plans showing locations of all telecommunication outlets and spaces.

END OF SECTION 271513

SECTION 271543 – FACEPLATES AND CONNECTORS

PART 1 GENERAL

1.01 Scope of work

- A. Work covered by this Section shall consist of furnishing labor, equipment, supplies, materials, and testing unless otherwise specified, and in performing the following operations recognized as necessary for the installation, termination, and labeling of faceplates and connectors as described on the Drawings and/or required by these specifications.

PART 2: PRODUCTS

2.01 Telecommunications Installation

- A. General: The materials and products specified herein reflect the minimum acceptable standards of fabrication and manufacture. All materials and products supplied by the Contractor and specified herein are to be new, unused, of first quality and in original packaging or shipping containers or as shown on drawings and described herein.
- B. New buildings and major renovations require Category 6a cabling. In some cases this will result in sections of the building being cabled differently than existing infrastructure due to advances in cable transport technologies. Contact the Purdue IT Infrastructure Services Representative for approval of cabling systems before installation.
- C. Standard PIC Room Outlet Devices in Flush Mounted Devices:
 - 1. Special Circuits requiring dedicated copper cable shall consist of (1) Panduit #CJ6X88TGVL, Violet, Category 6a, T568B wiring standard, 8 conductor jacks.
 - 2. Data device shall consist of (2) Panduit #CJ6X88TGVL, Violet, Category 6a, T568B wiring standard, 8 conductor jacks
 - 3. Cover plate shall be (1) Panduit #CBEIW-2GY, Office White, 2-gang, double opening wall plate with (1) Panduit #CHS2IW-X, sloped, Office White snap-in modules located in the top faceplate openings, and (3) Panduit #CHB2IW-X blank modules in the bottom faceplate openings. See Attachment #3.5 for jack configuration.
- D. Standard PIC Room Outlet Devices in Surface Mounted Raceway:
 - 1. Special Circuits requiring dedicated copper cable shall consist of (1) Panduit #CJ6X88TGVL, Violet, Category 6a, T568B wiring standard, 8 conductor jacks.
 - 2. Data device shall consist of (2) Panduit #CJ6X88TGVL, Violet, Category 6a, T568B wiring standard, 8 conductor jacks
 - 3. Cover plate shall be (1) Panduit #CBEIW-2GY, Office White, 2-gang, double opening wall plate with (1) Panduit #CHS2IW-X, sloped, Office White snap-in modules located in the top faceplate openings, and (3) Panduit #CHB2IW-X blank modules in the bottom faceplate openings. See Attachment #3.5 for jack configuration.
- E. Fiber Only Outlet Device:

1. Single-mode fiber device shall consist of (1) Panduit #CMDSLCZBU, Office White, LC single-mode fiber optic adapter module.
2. Cover plate shall be (1) Panduit #CBEIWY, Office White, single gang, single opening wall plate with (1) Panduit # CHS2IW-X , Office White, sloped snap-in module in bottom opening, and (1) Panduit #CHB2IW-X, Office White, blank fittings in top opening. See Attachment #3.9 for jack configuration.

F. Fiber Terminations

1. Fiber PICs consist of two strands but at labeled with one PIC designator. Contact Purdue IT Infrastructure Services Representative for labeling specifics.
2. Each single-mode fiber shall be terminated with (1) LC Ultra PC Polish fiber optic connector
 - Corning Cable Systems #95-200-99 Unicam
 - Corning #SOC-LCU-900-SM FuseLite® Connector
 - Panduit #FLCS2/9SOCU9BU LC Simplex Connector
 - Belden #AX101983 Optimax Field Installable Connector
 - Owner-approved equivalent
3. Where fiber jacks are being installed in a Standard PIC, see attachment #3.10 for jack configuration.

G. PIC Locations in Divided Raceways

1. Where jacks are being installed in a divided 4000 Wiremold raceway for telecommunications and power, utilize Wiremold #V4047C-1 one-gang device plates for the mounting of the Panduit #CBEIWY, Office White, single gang, single opening wall plate. Electrical devices shall utilize a separate Wiremold #V4048B duplex receptacle device. See Attachment #3.8 for jack configuration.

H. CATV Terminations

1. Type 6 (RG-6) Cable Installations
 - a. Terminate all RG-6 cable with Belden #FSNS6U compression connectors.
2. Type 11 (RG-11) Cable Installations
 - a. Terminate all RG-11 non-plenum cable with Belden #SNS1P11 compression type connectors.
3. CATV outlet within a PIC shall utilize (1) Panduit #CMFIW F-type module. See Attachment #3.6 for jack configuration.

I. Wall Phone PIC Room Outlet Devices in Flush Mounted Devices:

1. Wall Phone Outlets requiring dedicated copper cable shall consist of (1) Panduit #CJ6X88TGVV, Violet, Category 6a, T568B wiring standard, 8 conductor jacks.
2. Cover plate shall be (1) Panduit #CBEIWY, Office White, single-gang, double opening wall plate with (1) Panduit #CHS2IW-X, Flat, Office White snap-in modules located in the top faceplate openings, and (1) Panduit #CHB2IW-X blank module in the bottom faceplate opening. See Attachment #3.7 for jack configuration.

J Single-Gang Wall Phone PIC Room Outlet Devices in Surface Mounted Raceway:

1. Wall Phone device shall consist of (1) Panduit #CJ6X88TGVL, Violet, Category 6a, T568B wiring standard, 8 conductor jacks
2. Cover plate shall be (1) Panduit #CBEIW-2GY, Office White, 2-gang, double opening wall plate with (1) Panduit #CHS2IW-X, Flat, Office White snap-in modules located in the top faceplate openings, and (3) Panduit #CHB2IW-X blank modules in the bottom faceplate openings. See Attachment #3.7 for jack configuration.

PART 3 - EXECUTION

3.01 Telecommunications Installation

A. General:

1. This Section describes the installation locations for the products and materials, as well as methods and Owner's Standards associated with the Telecommunications Installation portions of the Project. These Specifications, along with the drawings and other Owner supplied specifications shall be followed during the course of the installation.
2. The Contractor is instructed to coordinate his efforts with the other tradesmen who may be working within the same vicinity to avoid conflict and lost time.
3. The Contractor is required to supply all necessary tools, equipment, accessories, safety equipment, protective clothing, etc., as customary for the craft and necessary for the installation.
4. The Contractor shall verify space requirements and locations with the Purdue IT Infrastructure Services Department before starting cable installations and terminations.
5. The Contractor shall verify the category of the data jacks required with the Purdue IT Infrastructure Services Department before starting termination.

3.02 CATV Termination

A. CATV Cable Termination:

1. All RG-6 CATV cable shall be terminated as follows:
 - a. Strip off 7/16" of outer jacket without disturbing braided shield underneath.
 2. Bend braided shield back over the outer jacket.
 3. Cut dielectric without scoring center conductor to obtain 3/16" of dielectric left.
 4. Slide the RG-6 connector down cable until dielectric is flush with inner surface and bottoms out.
 5. Compress fitting using appropriate compression tool.
- B. All RG-11 CATV cable shall be terminated as follows:
 1. Strip off 1/2" of outer jacket without disturbing braided shield underneath.
 2. Bend braided shield back over the outer jacket.
 3. Cut dielectric without scoring center conductor to obtain 3/16" of dielectric left.
 4. Slide the RG-11 connector down cable until dielectric is flush with inner surface and bottoms out.
 5. Compress fitting using appropriate compression tool.

3.03 Equipment Installation and Cable Terminations

- A. All equipment shall be installed in a neat and workmanlike manner, arranged for convenient operation, testing and future maintenance.

- B. All telecommunications cables, faceplates, and connectors shall be installed and terminated by technicians experienced in the installation and termination of telecommunications items listed herein.
- C. The Contractor shall employ certified system installation technicians and have at least 5 years of experience in the installation of similar and equivalent systems.
- D. The Contractor shall supply verification of experience, for this type of work, to the Architect for approval before performing any work.

3.04 As Built Information

- A. Contractor shall provide as-built information and all test result information to the Purdue IT Infrastructure Services Department.
- B. As-built information shall be in red-lined format on a copy of construction drawings. Indicate location of all PICs, skeletal and riser conduit routes, distribution cable trays, junction boxes, and all additions and deletions pertaining to telecommunications. Include correct PIC labeling next to all telecom symbols.
- C. If construction drawings are not utilized, Contractor shall provide all telecommunications location information on an accurate scaled floor plan.
- D. Contractor shall perform all labeling requirements and provide testing documentation for verification as described herein.
- E. Contractor shall submit cable records to reflect all moves, adds, and changes.
- F. Contractor shall provide floor plans showing locations of all telecommunication outlets and spaces. Electronic versions of as-builts are preferred.

3.5 Standard PIC Faceplate Configuration:

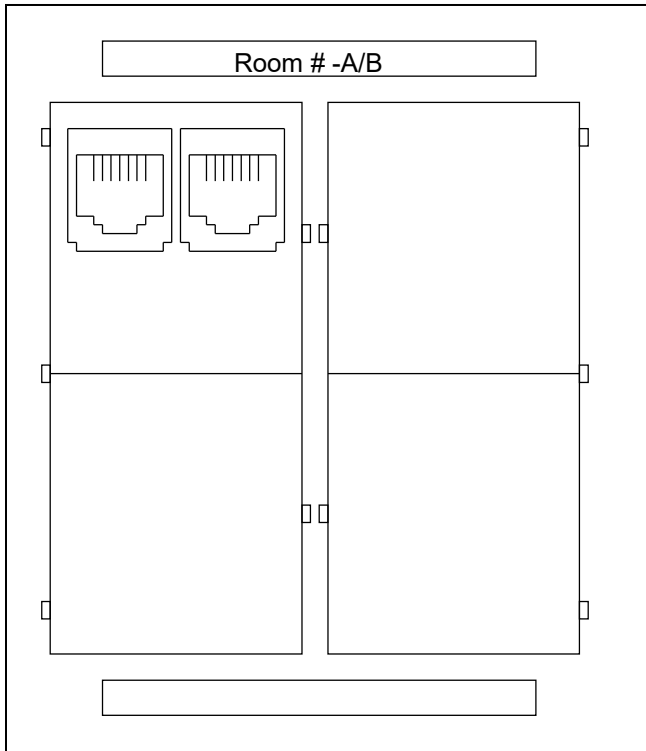

3.6 Standard PIC Faceplate Configuration with CATV:

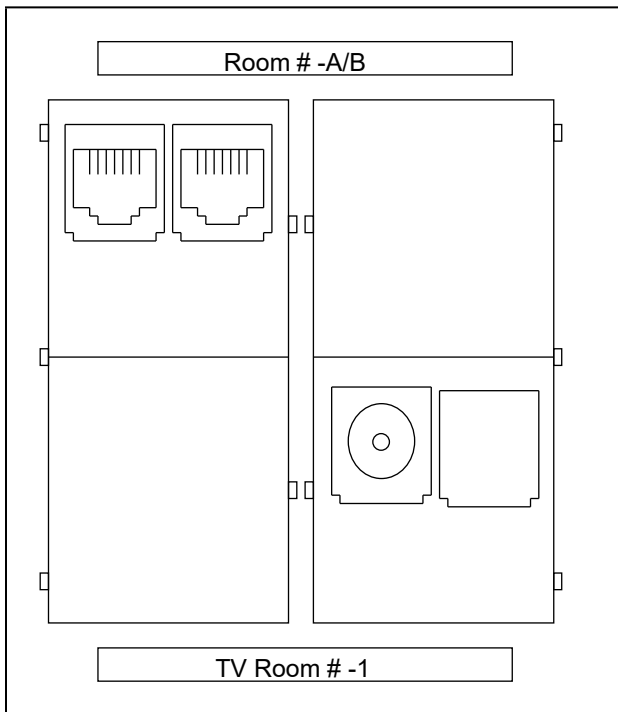

3.7 Telephone Only Faceplate Configuration in a Single-Gang Faceplate:

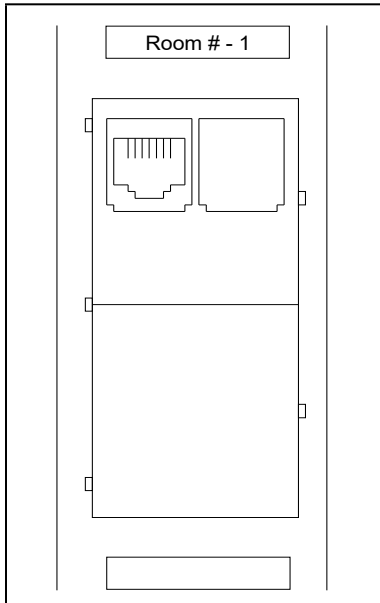

3.8 Data Only Faceplate Configuration in a Single-Gang Faceplate:

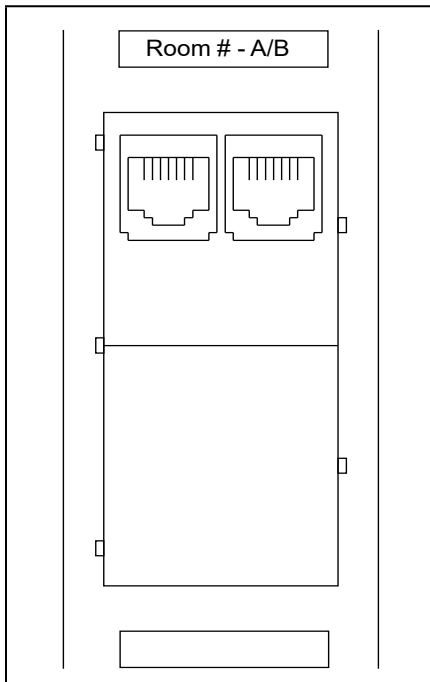

3.9 Single Mode Fiber PIC Faceplate Configuration in a Single-Gang Faceplate:

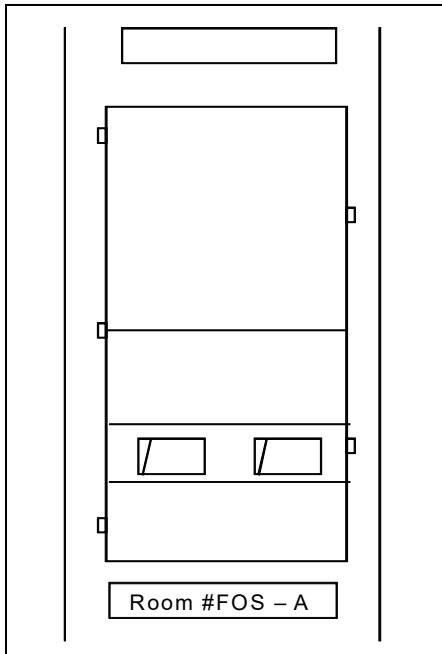

3.10 Standard PIC with Fiber Faceplate Configuration:

