



**INDIANA DEPARTMENT OF TRANSPORTATION**

# Karst Geological Resources and INDOT Construction

Ecology and Waterway Permitting Office  
Environmental Services Division

Revised 11/21/2017

# Table of Contents

<b>I. Introduction.....</b>	<b>3</b>
<b>II. Karst Geology.....</b>	<b>3</b>
A. Development of Karst Features.....	3
B. Types of Karst Features.....	4
C. Karst in Indiana.....	7
D. Karst Aquifers.....	8
<b>III. Cave Biology.....</b>	<b>9</b>
A. Cave Zones.....	9
B. Cave Food Pyramid.....	10
C. Cave Fauna.....	10
<b>IV. Protection of Karst Resources.....</b>	<b>12</b>
A. Hazards.....	12
B. Legal Protection of Karst Features.....	14
C. Karst Memorandum of Understanding (MOU).....	16
<b>V. Site Investigation and Documentation.....</b>	<b>17</b>
<b>VI. Karst and INDOT Construction.....</b>	<b>21</b>
A. Regulatory Compliance.....	21
B. Best Management Practices (BMPs).....	22
C. Impact Mitigation.....	23
D. Construction Mitigation Methods.....	24
E. Post-Construction Mitigation.....	28
<b>Appendix A Terminology.....</b>	<b>30</b>
<b>Appendix B References.....</b>	<b>33</b>
<b>Appendix C Karst Memorandum of Understanding (MOU).....</b>	<b>35</b>
<b>Appendix D Karst Standard Operation Procedure.....</b>	<b>40</b>
<b>Appendix E DNR Subterranean Systems Habitat Summary.....</b>	<b>42</b>

## Table of Figures

Figure 1. Solution features characteristic of karst terrains .....	3
Figure 2. Bedrock dissolution process .....	6
Figure 3. Generalized physiographic cross section of southern Indiana .....	7
Figure 4. Physiographic divisions of southern Indiana .....	8
Figure 5. Cave zones .....	9
Figure 6. Cave food pyramid .....	10
Figure 7. Legal protection of karst resources .....	15
Figure 8. MOU Potential Karst Features Region.....	17
Figure 9. Karst Resources in Study Area .....	18
Figure 10. Imagery\Quad_24K for Study Area .....	18
Figure 11. Imagery\BestAvailable for Study Area .....	19
Figure 12. Hillshade_Elevation\Statewise_DEM-11_13 .....	19
Figure 13. LIDAR hillshaded image of Wesley Chapel Gulf in Orange County. ....	20
Figure 14. Rock ring .....	23
Figure 15. Typical aggregate cap sinkhole treatment .....	24
Figure 16. Typical sinkhole treatment concrete cap .....	25
Figure 17. Typical lined drainage ditch with clay layer protection .....	26
Figure 18. Karst seep or spring outlet .....	27
Figure 19. Offset structure .....	27
Figure 20. Spring Box .....	28

## I. Introduction

Karst is a landscape feature that is formed by the dissolution of a layer or layers of soluble rock by acidic water. The two types of soluble rock found in the karst regions of Indiana are limestone and dolomite. The acidity of rain water increases as it absorbs carbon dioxide ( $\text{CO}_2$ ) as it moves through the subsurface, forming carbonic acid ( $\text{CO}_2 + \text{H}_2\text{O} \rightleftharpoons \text{H}_2\text{CO}_3$ ). Karst features contain sensitive ecological communities that are susceptible to environmental changes that may be caused by construction or use of INDOT roadways.

Understanding the geology of a project area includes understanding the type of bedrock that lies below the surface, the surface landforms, and the materials above the bedrock, including soils. For most roadway projects, the type and depth of bedrock generally does not have a strong influence on location, design or construction. In most areas it also is not a consideration when evaluating potential environmental impacts. However, projects located in karst areas may require special consideration of karst features in site evaluation, selection, project design, and environmental impact avoidance.

## II. Karst Geology

### A. Development of Karst Features

Karst features are formed as acidic water dissolves the subsurface rock, forming cracks and fissures. The water moves sideways along horizontal cracks between rock layers (bedding planes) and fractures or joints in the rock. In many karst areas, there is little surface water because most of it has entered the subsurface water flow of the karst system.

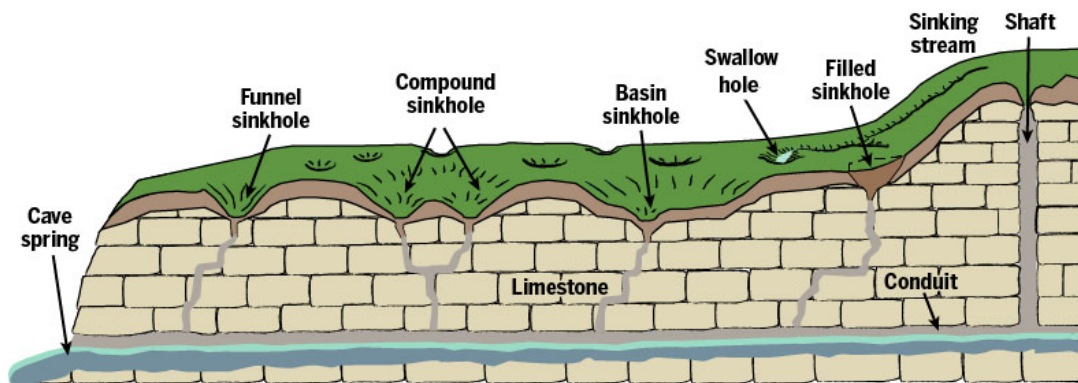

**Figure 1. Solution features characteristic of karst terrains**  
Hasenmueller and Powell, 2005 as found on the Indiana Geological Survey website

## B. Types of Karst Features

There are many types of karst physiographic features present in Indiana.

- Cave – A cave is an air-filled underground void that is large enough to be entered by a person.



**Cave entrance**

**Photo credit Lochmueller Group**



**Cave mouth**

**Photo credit Parsons**

**Rock column collapse through sandstone into limestone cave system.**

**Photo credit Lochmueller Group**



- Sinking/losing stream – A sinking or losing stream has a bed that allows water to flow directly into the groundwater system.
- Natural bridge or tunnel – A natural bridge or tunnel is a void beneath standing bedrock. It has a short length but will be large enough to allow human passage. A natural bridge is shorter than a tunnel and is more often air- rather than water-filled.
- Spring – A spring is a natural resurgence of groundwater from a karst groundwater system to the surface. Springs are usually located along a hillside or on a valley floor.





**This small spring located in limestone has diminished and variable flow.  
Photo credit Lochmueller Group**



**This spring has artesian flow from a submerged cave.  
Photo credit Lochmueller Group**

- Swallet/swallow hole – A swallet or swallow hole is an area where a stream sinks into the subsurface.
- Sinkhole or sink – A sinkhole or sink is a collapsed portion of bedrock above a void. It creates a basin- or funnel-shaped surface depression ranging from a few feet to several hundred feet in diameter and from a few feet to several hundred feet in depth.



**Sinkholes  
Photo credit Parsons**

The development of Karst features is illustrated by the two mechanisms that can create sinkholes. The first mechanism is the upward raveling (or undoing) of soil over a cavity in the bedrock and the development of a soil arch. Chemical dissolution of the bedrock in conjunction with the mechanical weathering of the overlying soil results in a sinkhole. This is illustrated in Figure 2. The dissolution of the bedrock starts with the movement of surface water through the overburden into the bedrock (A), the development of a soil arch as the bedrock collapses and the overburden begins to fall into developing hole (B and C) and the final collapse of the overburden and the creation of the sinkhole (D).

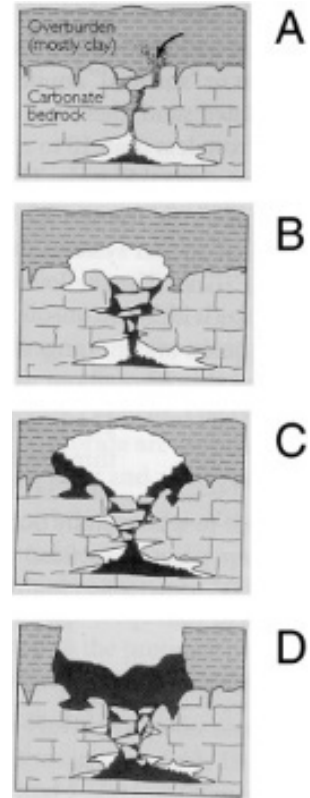

**Figure 2. Bedrock dissolution process**  
Source USGS

The second mechanism occurs as the result of water table variability. Soil strength is based on water content. The soil strength is low when there is insufficient water to interlock the soil particles. Soil strength increases as water content increases. There is a point where the weight of the water will overcome the soil strength and the soil will collapse. When there is a rapid increase or fluctuation in water content, changes in the effective stress load (the force that keeps a collection of particles rigid) will lead to failure.

The epikarst zone is the interface between soil and rock in karst landscape. It is characterized by fracturing and solution pockets that can be filled with water. It stores and directs percolation water toward the vertical drains or springs in the karst.

The hydrologic characteristics associated with the presence of karst include:

- Internal drainage of surface runoff through sinkholes;
  - Underground diversion or partial subsurface piracy of surface streams (sinking and losing streams);
  - Temporary storage of ground water within a shallow, perched epikarst zone;
  - Rapid, turbulent flow through subsurface pipelike or channellike solutional openings called conduits; and
  - Discharge of subsurface water from conduits by way of one or more large perennial springs.
- (Taylor and Greene, 2008, 75)



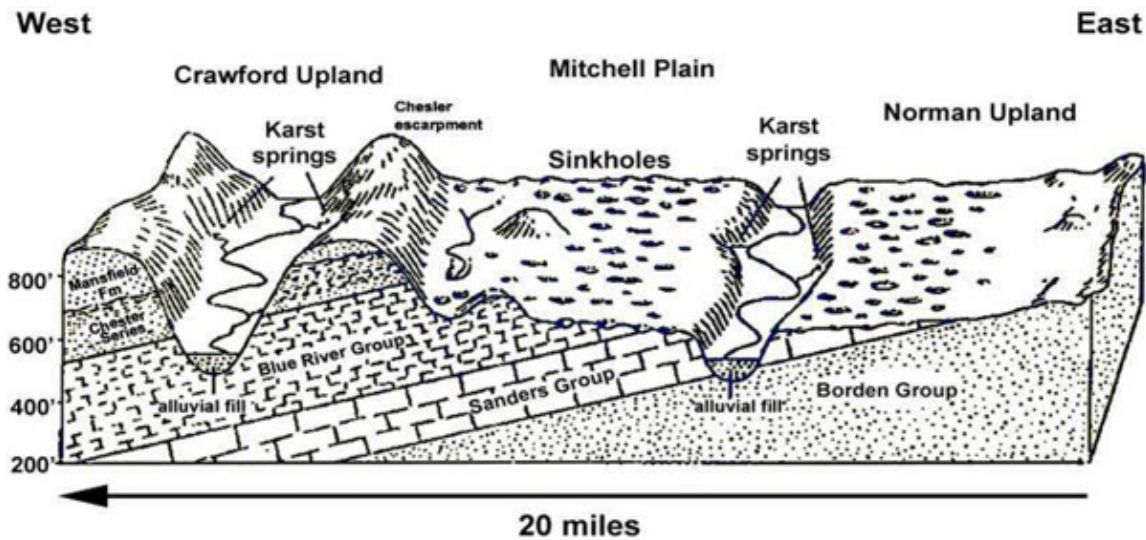

**Figure 3. Generalized physiographic cross section of southern Indiana  
From Palmer, 1969 as found on the Indiana Geological Survey website**

### **C. Karst in Indiana**

There are two primary areas of karst landscape located in Southern Indiana: the Mitchell Plateau and the Crawford Upland (see Figure 4). The Mitchell Plateau extends from the eastern part of Owen County southward to the Ohio River in Harrison County and into Kentucky. It developed on Mississippian carbonates. The Crawford Upland, located west of the Mitchell Plateau, is characterized by ridges and valleys developed on shale, sandstone, and carbonate strata of Mississippian age. Sinkholes, karst valleys, and caves are common along the border between the two areas. Two other areas can be found east of the Norman Upland: the Muscatatuck Plateau and Charleston Hills. The northern two-thirds of Indiana are covered with thick unconsolidated glacial material that covers potentially karstic rock layers. There are also areas along the Wabash River, outside of the typical karst areas, where the karst features are exposed due to thin or absent glacial materials.

Two types of rare and ecologically important wetland types can be found in karst topography: sinkhole ponds and sinkhole swamps (see 327 IAC 17-1-3(3)(B)). Sinkhole ponds are water containing depressions. A sinkhole swamp is a depression that is dominated by tree or shrub species. Both can be found in the Mitchell Karst Plain.



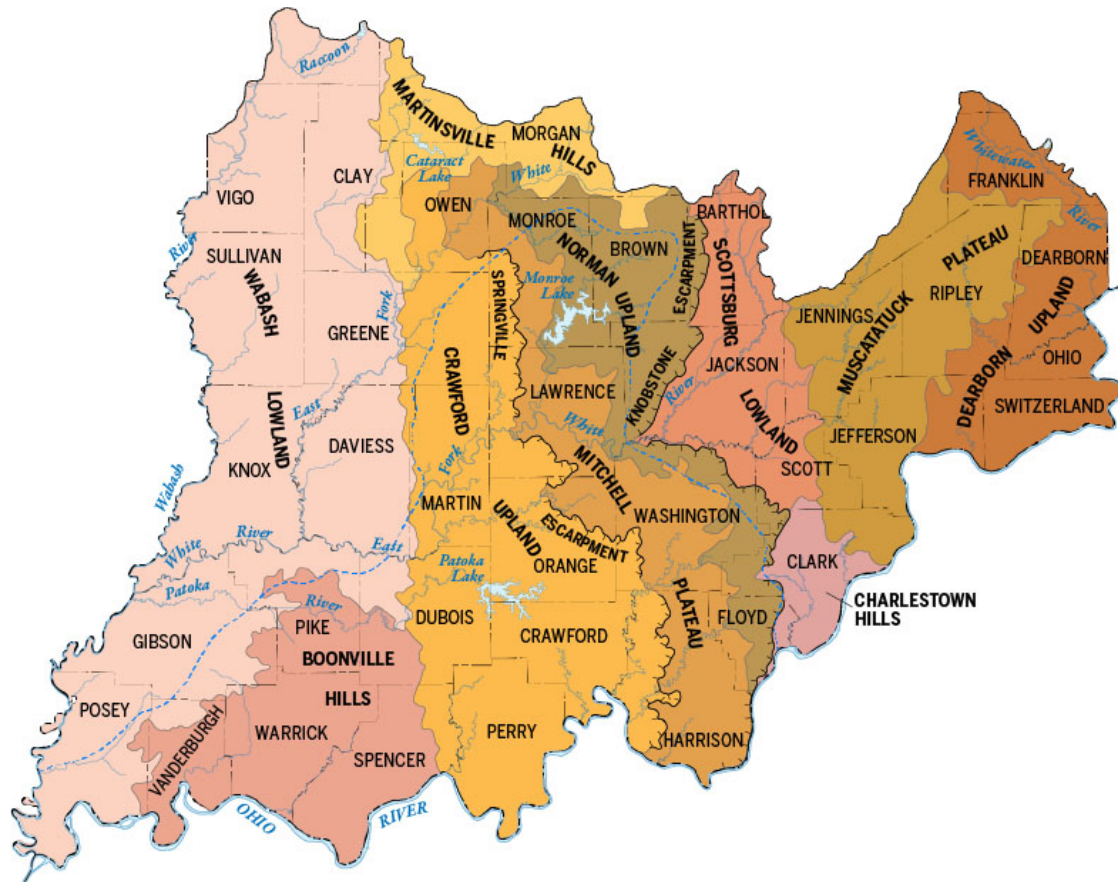

**Figure 4. Physiographic divisions of southern Indiana**  
 Source Indiana Geological Survey

## D. Karst Aquifers

An aquifer is a body of bedrock, or other earth material, from which useable quantities of groundwater can be produced by a well or spring. An aquifer can be composed of granular materials such as loose sand and gravel or weakly cemented bedrock. The groundwater flows very slowly through these aquifers between the grains of sand or gravel, or through narrow fractures in the bedrock. The small openings in the surface soil layer act as a filter and physically or chemically remove bacteria, viruses and polluting chemicals. Sinking streams, swallow holes and other features with a limited or absent surface soil layer provide limited filtration and may result in contamination from fecal bacteria and other pollutants.

Unlike a typical aquifer, the drainage pattern of a karst aquifer resembles the branching pattern formed by streams flowing above ground. Water will enter a karst aquifer either directly, through swallow holes and sinkholes, or indirectly, through the pores in the soil overlying the limestone

bedrock. As the volume of water increases in response to surface rainfall in the enclosed channel, the pressure will increase. Water will move through the channel in a manner similar to water going through a hose.

The flow of water on the surface will follow the topography, creating drainage basins. A groundwater basin boundary will have little relationship to surface drainage patterns and may cross surface watershed boundaries. This creates challenges in mapping water flow through the karst features.

### III. Cave Biology

#### A. Cave Zones

Caves and karst areas contain unusual organisms that have adapted to the specialized and fragile habitat. Cave habitats can be classified into two groups – terrestrial and aquatic. Terrestrial animals include bats, crickets, and harvestman. Aquatic animals include cave fish, amphipods, crayfish, and salamanders.

Cave habitats can be divided by light zone. The entrance zone is the area just inside the cave opening. This area receives sunlight that allows some plant growth and an exchange of animals that might also be seen living above ground. The twilight zone is the area farther from the entrance where the light begins to diminish. The dark zone begins where the cave becomes completely dark and extends throughout the rest of the cave.

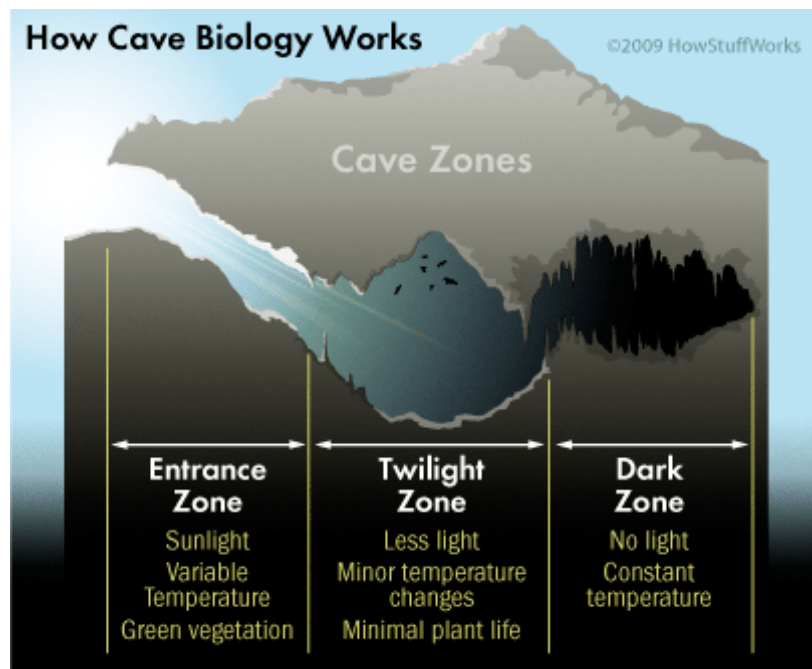

**Figure 5. Cave zones**  
Source HowStuffWorks

The caves can also be divided into two habitats. The Subterranean Systems Cave Entrances includes the surface openings and reaching as far as the natural light can penetrate (entrance and twilight zones). The Subterranean Systems Caves includes the connected underground rooms and

passages beyond natural light penetration (dark zone). See Appendix D for the IDNR “Subterranean Systems Habitat Summary.”

## B. Cave Food Pyramid

In addition to adaptation to live in low to no-light where there is limited primary production, karst species have adapted to live on a limited food supply. The nutrients are brought into the cave from outside in the form of organic debris, seeds, and nuts carried in on flowing water. Organic matter is also introduced by eggs, feces, dead insects and other animals, which cycles through the cave inhabitants as illustrated in the following cave food pyramid.

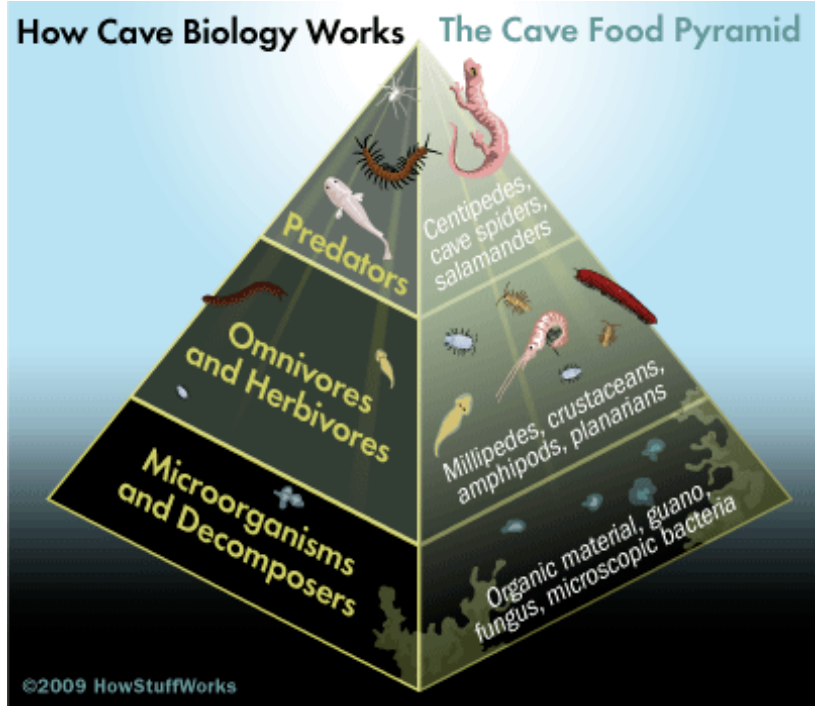

Figure 6. Cave food pyramid  
Source HowStuffWorks

## C. Cave Fauna

Caves serve important roles. For example, caves serve as bat hibernacula for the endangered Indiana (*Myotis sodalis*) and northern long-eared bats (*Myotis septentrionalis*).

**In the background, Indiana bats (*Myotis sodalis*) are drinking from water that has condensed on the cave wall.**

**Photo credit USFWS; Andrew King**





Cave fauna can be classified by the amount of their life cycle spent in or adapting to the cave environment and whether they are terrestrial (troglafauna) or aquatic (stygofauna) based. Some animals find temporary shelter, a resting place, or hunting ground in a cave. These troglaxenes and stygoxenes spend much of their time above ground. They use the caves for a specific part of their life cycle such as hibernation, nesting or giving birth but they must go above ground for other parts of their life cycle, such as foraging for food or to mate. Examples of troglaxenes include: bats, bears, foxes, raccoons, snakes, crickets, moths, and swallows. Stygoxenes are surface-dwelling stream animals such as fish, crayfish, and freshwater mussels.

**Ortmann's Mudbug**  
*(Cambarus ortmani)*  
Photo credit IDNR



Animals that can complete their life cycle either above or below ground are called troglaphiles and stygophiles. These animals are adapted to survive their entire life in a cave, but they can also live in a suitable habitat above ground. Examples of troglaphiles include: beetles, terrestrial crayfish, pigmented earthworms, millipedes and centipedes. Examples of stygophiles are springfish and some salamanders.

**Cave salamander (*Eurycea lucifuga*)**  
Photo credit asih.org





Animals adapted to live entirely in caves are called troglobites and stygobites. They cannot survive above ground and have adaptations to help them find food, avoid predators, and complete their life cycles in the total darkness of the caves. These adaptations include long antennae and vibration sensory organs, a good sense of smell, long fins or legs, smaller bodies than surface species, low metabolic rates, few eggs, and a long life span. Some have little or no pigmentation and smaller or no eyes in the adult stages. Examples of troglobites include cave millipedes, some beetles and cave spiders. Stygobites include blind crayfish, blind cavefish, blind cave salamanders, and cave shrimp.

**Banded sculpin (*Cottus carolinae*)**

**Photo credit [cape.k12.mo.us](http://cape.k12.mo.us)**



## IV. Protection of Karst Resources

### A. Hazards

Karst terrain is environmentally sensitive. It is geologically and ecologically vulnerable to contamination because of the unpredictability of contaminant transport mechanisms, the exceptional value of the resource, and the human or ecological risks that may result from contamination. Contamination enters karst through the openings and conduits formed by the disintegration of rock, which allows it to move rapidly through the system. In addition, these systems are complex and may disperse contamination unpredictably and rapidly. The contaminants may also get trapped in pools, sediments, and minor fractures. In addition, the species that have adapted to the karst environment may be impacted by minor changes in water quality.

Point source contamination of karst features can come from spills, leaking underground storage tanks, and household septic systems. Broad area contamination can come from road salts, vehicle emissions, pesticides, and fertilizers.

Groundwater contamination in karst areas is a serious concern. Generally the groundwater table is shallow, and the karst features allow rapid movement of surface waters into the subsurface. The opportunity for the contaminants to be filtered by soil and bedrock or exposed to sunlight is

limited. The contaminants can come from spills or the application of insecticides, herbicides, fertilizers and other chemicals on the surface. Contaminants can also be introduced through other human activity such as the use of the feature as a disposal site for solid waste and organic matter (lawn waste, animal waste and sewage). Decomposing organic matter will lower the oxygen content of the water and in sufficient quantities kill cave-dwelling aquatic animals. The organic matter will also promote the transport of other contaminants.

When sinkholes are clogged by surface runoff or other materials, they are not able to drain surface waters. In addition, the increase of impermeable surface water flows may also overwhelm the sinkholes. This alteration of drainage patterns may result in increased surface flooding.

**This photo shows an area of karst flooding near Bellevue, Ohio. Surface and near-surface geologic conditions, combined with increased precipitation, resulted in the groundwater rising to the surface, flowing from existing sinkholes, and filling closed basins and sinkholes, caverns and underground drainage passageways.**

**Source Indiana Geological Survey,  
Photo credit Douglas Aden**



Indiana sinkholes develop in well-cemented, dense carbonate formations. In other areas of the country, less consolidated formations develop collapse features (mistakenly called sinkholes). These features result from leaking swimming pools, water or sewer lines, or other unnatural factors and can be a hazard.

**This sinkhole developed in Mississippian carbonate rock in Lawrence County, Indiana.**

**Source Indiana Geological Survey,  
Photo credit Samuel Frushour**



## **B. Legal Protection of Karst Features**

Karst features are indirectly protected through federal and state laws because they provide a conduit between surface and groundwater or provide habitat for protected species. They are not directly protected by state or federal law. Figure 7 provides a diagram of the federal, state and local government agencies, their areas of concern and source of legal authority.

Karst resources could result in higher level scrutiny under the National Environmental Policy Act (NEPA) because of the other related resources tied to the features. Section 7 consultation with the U.S. Fish and Wildlife Service (USFWS) would be required if there was the potential for federally endangered species within or near the resource. An example would be the presence of a cave used by endangered bat or fish species. Section 106 consultation would be required if there was the potential for archeological resources in the area, such as evidence of use by Native Americans or early settlers. Indiana does have one directly protected feature. The Orangeville Rise, located in Orange County, is designated as a National Natural Landmark. It contains one of the largest sinking and subterranean streams (Lost River) in the country.

**Orangeville Rise,  
Orange County, Indiana  
Photo credit The Nature  
Conservancy**

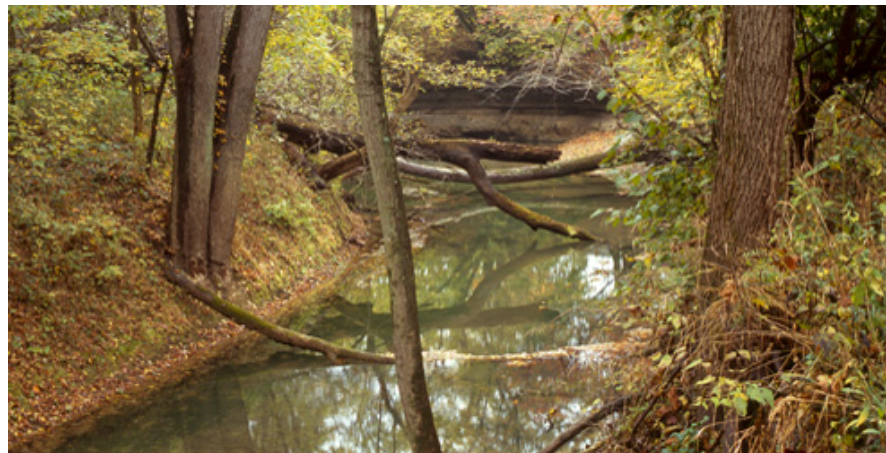

Coordination or consultation with the USFWS is required under the Endangered Species Act (ESA) where an endangered species was connected to the karst feature. The prime example of this is the use of caves by the endangered Indiana Bat and Northern Long-Eared Bat as hibernacula or by the northern cave fish. The cave would be designated as a protected habitat under the ESA.

The Environmental Protection Agency (EPA) considers some karst features (sinkholes and swallow holes) to be Class V injection wells if alterations are made to the drainage system that increase the amount or type of runoff received by the feature. If a project impacts a feature, the project sponsor must provide the EPA with inventory information about the feature and implement measures that will protect underground sources of drinking water.

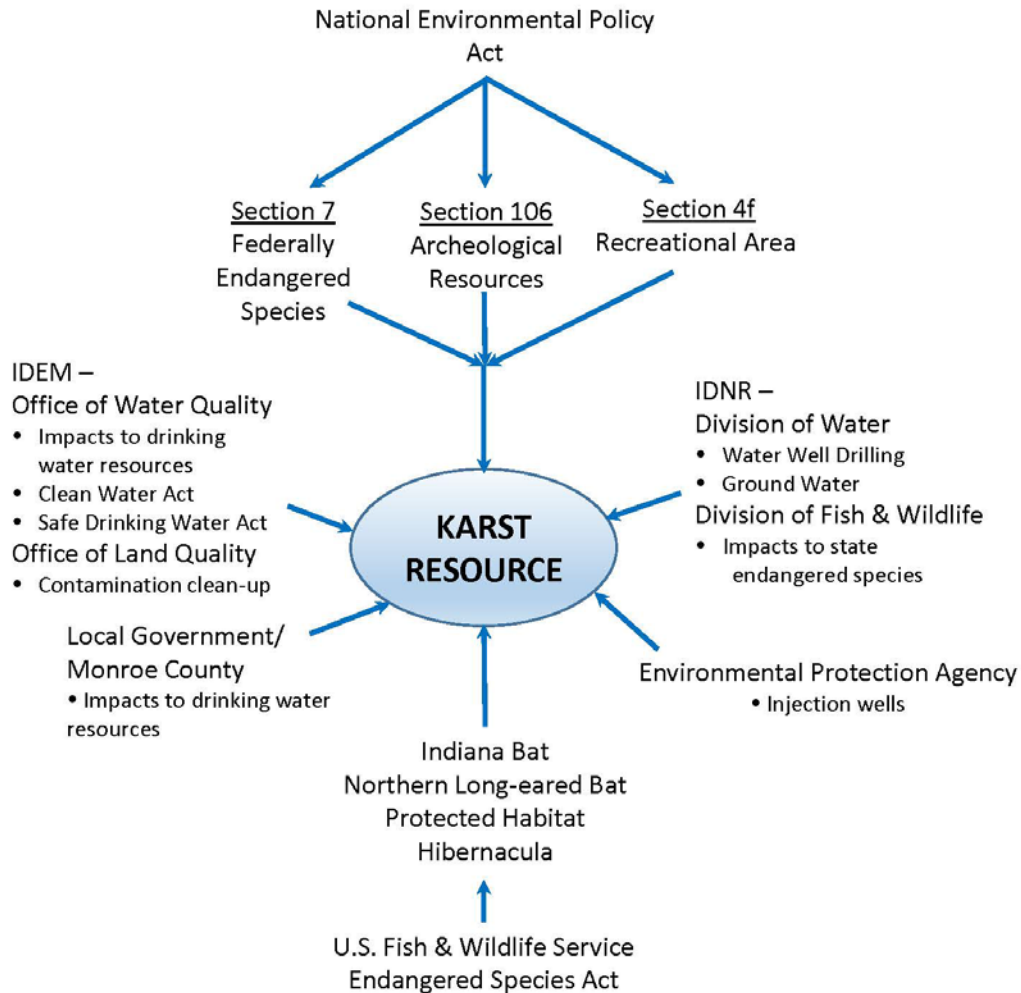

**Figure 7. Legal protection of karst resources**  
**Source INDOT**

Potential impacts to karst resources resulting from INDOT projects would more frequently fall under the jurisdiction of state agencies. IDEM’s Office of Water Quality Ground Water Section addresses potential impacts to karst features from the perspective of the protection of surface water and drinking water resources under the Clean Water Act and the Safe Drinking Water Act. IDEM’s Office of Land Quality has oversight over potential contamination of a feature or the cleanup of a feature that has been contaminated. The Ground Water Section will contact the Office of Land Quality if they have any concerns.

IDNR’s Division of Water regulates the drilling, casing, operating, plugging, and abandoning of wells and any related fluid storage. They have a nonrule policy document to provide supplemental protection to karst areas of the state during drilling operations. The policy includes



exclusion of drilling activity within known cave limits and a buffer zone around them. The document also provides drilling procedures for karst areas. The drilling or boring logs from wells maintained by the agency are a useful tool in mapping karst resources. They may also be involved where a project may impact groundwater resources.

The IDNR Division of Fish & Wildlife would be involved if the project had the potential to impact state-listed species. Under the Karst MOU, discussed in the next section, it is IDNR's responsibility to provide a biological review of projects located in karst areas.

Karst topography may also be covered under other local government ordinances. Currently, Monroe County is the only county with this type of ordinance. The Monroe County Zoning Ordinance Chapter 829 provides Karst and Sinkhole Development Standards. The ordinance establishes review procedures, use limitations, design standards and performance standards related to site development that may impact sinkholes or other karst features. The chapter prohibits development in those areas unless it has been demonstrated that the development would have "no significant detrimental impact on storm water management or ground water quality." Sinkhole conservancy areas must be established in all sinkhole areas that require a sinkhole evaluation and plan. New construction of streets and highways is prohibited without a determination by the County Highway Engineer and Drainage Engineer that "traffic safety considerations outweigh storm water and water quality considerations." This requires the completion of a sinkhole evaluation and plan, submittal and approval of an improvement location permit. The ordinance also provides guidance on the evaluation of the sinkhole flooding area and sinkhole watershed.

Coordination with local government organizations in the project area will occur as part of NEPA compliance. Concerns regarding the impact of the project on local water resources may be presented at that time. For example, the U.S. 50 North Vernon East Bypass has the potential to contaminate North Vernon's drinking water source through karst features located in the project area. Modifications were made to address those concerns to include installation of hazardous material traps and the purchase of an old quarry as new reserve water source.

### **C. Karst Memorandum of Understanding (MOU)**

On October 13, 1993, the Indiana Department of Transportation (INDOT) entered into a Memorandum of Understanding (MOU) with the Indiana Department of Natural Resources, the U.S. Fish and Wildlife Service and the Indiana Department of Environmental Management. The MOU established guidelines for the construction of transportation projects in an area designated as "Potential Karst Features Area of Indiana." For karst features located outside of the designated Potential Karst Features Area, consultation with one or more of the signatories of the karst MOU should be initiated. A karst study may be completed at the discretion of INDOT or be required by



The following series of photos are of an area southeast of Fayetteville, Indiana. They show the karst information available through the State of Indiana Geographical Information Library and accessible through IndianaMap, the 24K topographic map, aerial photo and the hillshade elevation data.

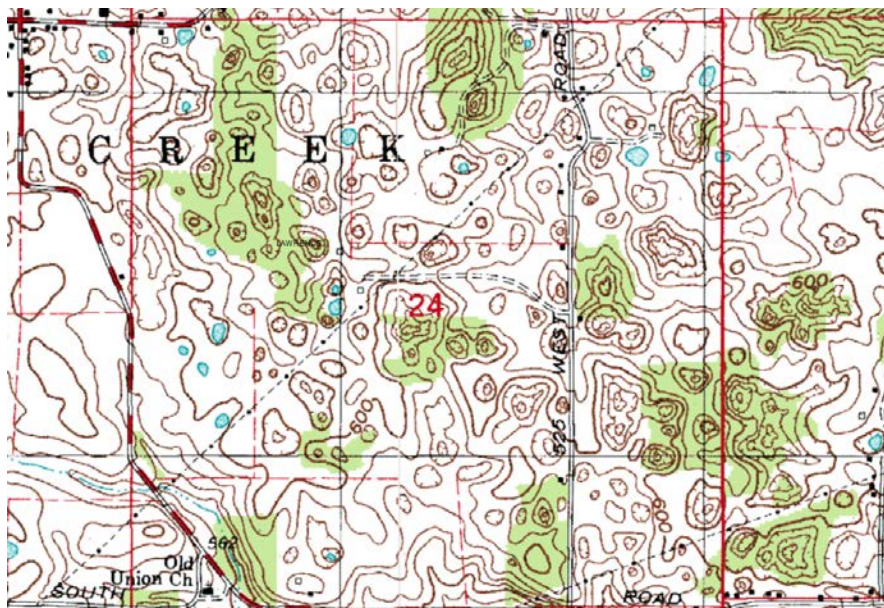
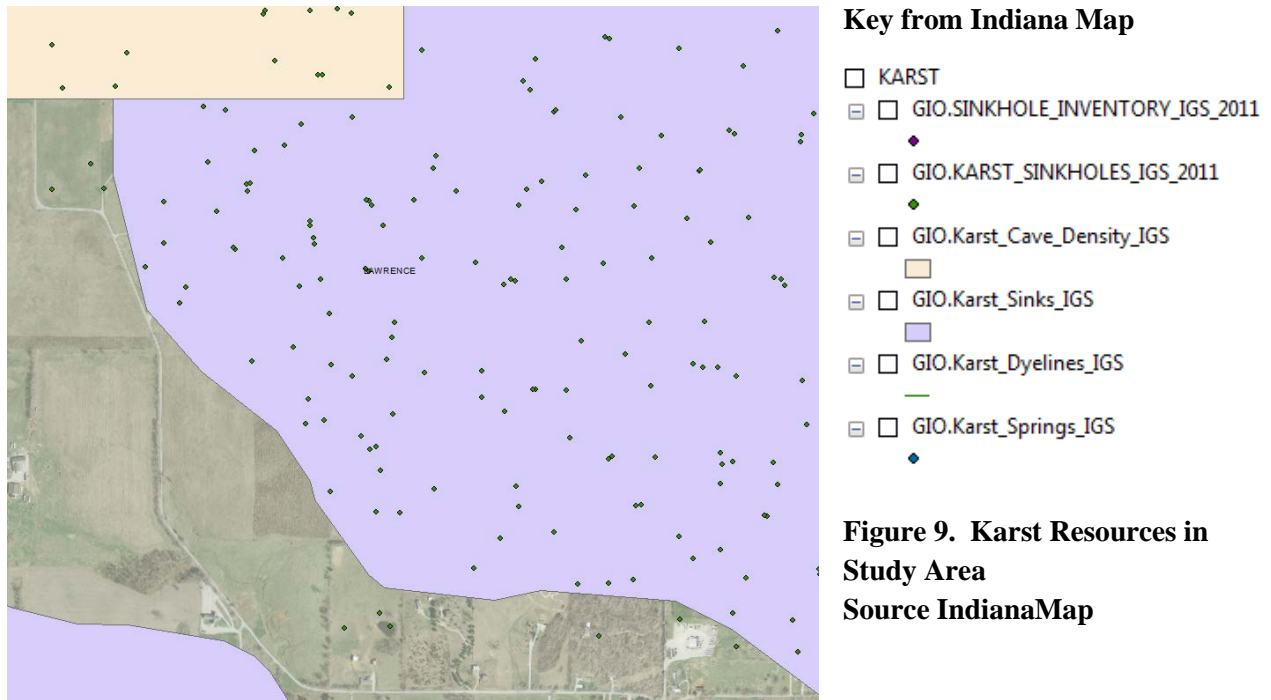





**Figure 11.**  
**Imagery\BestAvailable**  
**for Study Area**  
**Source IndianaMap**

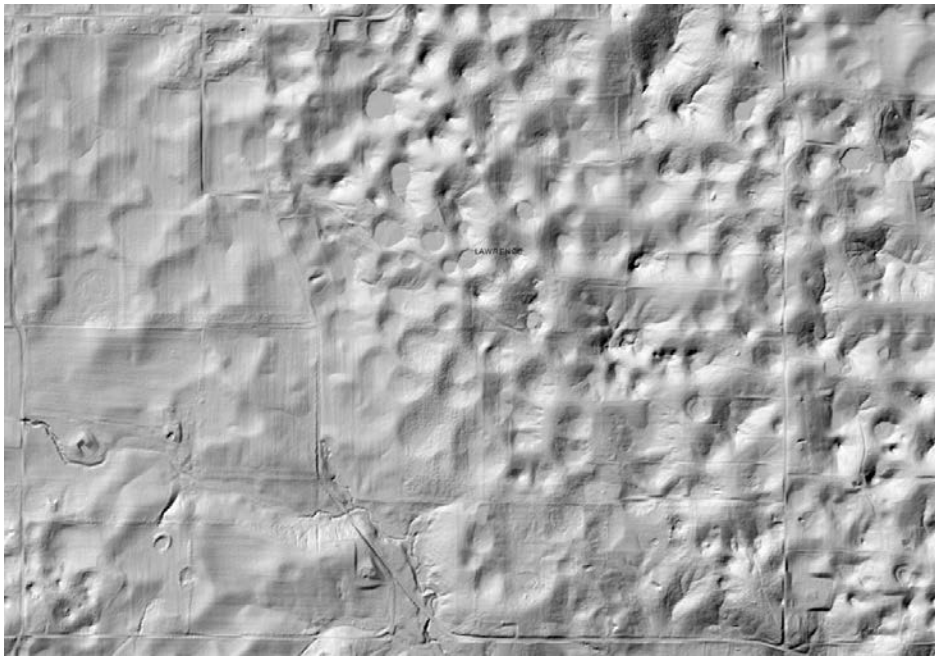
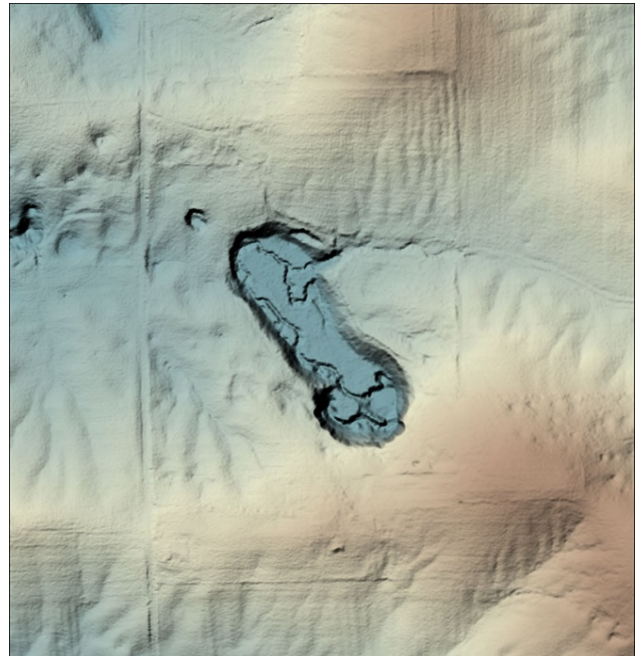

**Figure 12.**  
**Hillshade\_Elevation\**  
**Statewise\_DEM-11\_13**  
**Source IndianaMap**



This is a LIDAR hillshaded image of Wesley Chapel Gulf in Orange County, Indiana, compiled using IndianaMAP.

**Figure 13. LIDAR hillshaded image of Wesley Chapel Gulf in Orange County**  
**Source Indiana Geographic Information Council, 2013, IGS**



2) On-site Investigation. Investigate the site for visual indicators of karst features and document each feature to include location, photographs, and description. If possible, the site should be investigated during heavy rains to identify and map natural drainage patterns.

3) Geotechnical Investigation. If active karst is present in the area, a detailed geotechnical investigation should be conducted based on the size and type of the project and the complications posed by the karst geology. The investigation would include the use of borings or observation wells and would expand until there is sufficient understanding of the site. An INDOT pre-qualified karst scientist should design and supervise the data collection.

a) The information collected should include information such as:

- Bedrock characteristics such as the type, geologic contacts, faults, geologic structure, and rock surface configuration;
- Depth to water table and depth to bedrock;
- Soil characteristics such as type, thickness and mapped unit;
- Bedrock outcrop areas;
- Sinkholes or other closed depressions, and;
- Perennial or intermittent streams and their flow behavior.

b) Geophysical data collection techniques that may be used include seismic refraction, ground-penetrating radar, and electric resistivity. Dye tracing can be used to trace flow patterns from surface points to sampling wells or to trace subsurface flow patterns.

**Dye tracing**

**Photo credit <http://www.naraddyes.com/products.htm>**



4) Documentation. A karst report should be written and must include the project's scope and setting; how and where karst features are located; survey results that determined how features are related; and ways to avoid, minimize or mitigate impacts to karst features. Prior to release to the public, all sensitive information, such as feature location and presence of endangered species, must be removed from the report.

5) Implementation. The investigation should be used to avoid the identified features during project design. If avoidance is not possible appropriate mitigation methods must be designed for each feature. As part of the design process a post-construction monitoring plan must be developed for the project.

## VI. Karst and INDOT Construction

### A. Regulatory Compliance

INDOT compliance with IDEM's Rule 5 program during project construction will protect karst features from the discharge of sediment and other construction related pollutants. Compliance with INDOT's Rule 13 general storm water permit issued by IDEM will protect karst resources from changes in surface water quality. Compliance with the karst MOU will protect the roadway from collapse as a result of unidentified or improperly treated features.

## **B. Best Management Practices (BMPs)**

For karst features, Best Management Practices (BMPs) are structures that filter storm water runoff or to seal a feature from future runoff. Features are sealed to prevent continued erosion of bedrock underneath or adjacent to a roadway. BMPs also filter pollutants carried by storm water runoff. Without filtration, the runoff will pass quickly through the subsurface and as a result there is a greater risk of groundwater contamination. BMPs can also include using a no-salt/low-salt/low-spray strategy, developing an emergency response plan and using a stop work plan if any potentially federal and/or state listed species are encountered during construction.

Karst features must be protected from sediment and other contaminants during construction. The common method of protecting features during the initial construction phase is by encircling the feature with a rock ring. Figure 9 shows a typical design for a rock ring used on the U.S. 50 North Vernon Bypass. It consists of a band of coarse aggregate #2 (at a 3:1 slope) with the outside edge covered with coarse aggregate #3 (at a 2:1 slope). The rock ring retains the surface flow and filters sediments prior to entering the feature. As with any BMP, monitoring and maintenance must occur throughout construction on order for the BMP to be effective in protecting the karst feature.



**Rock ring protecting a very large karst feature on the U.S. 50 North Vernon Bypass  
Photo credit INDOT**

**Figure 14. Rock ring,  
typical design for U.S.  
50 North Vernon  
Bypass  
Source INDOT**

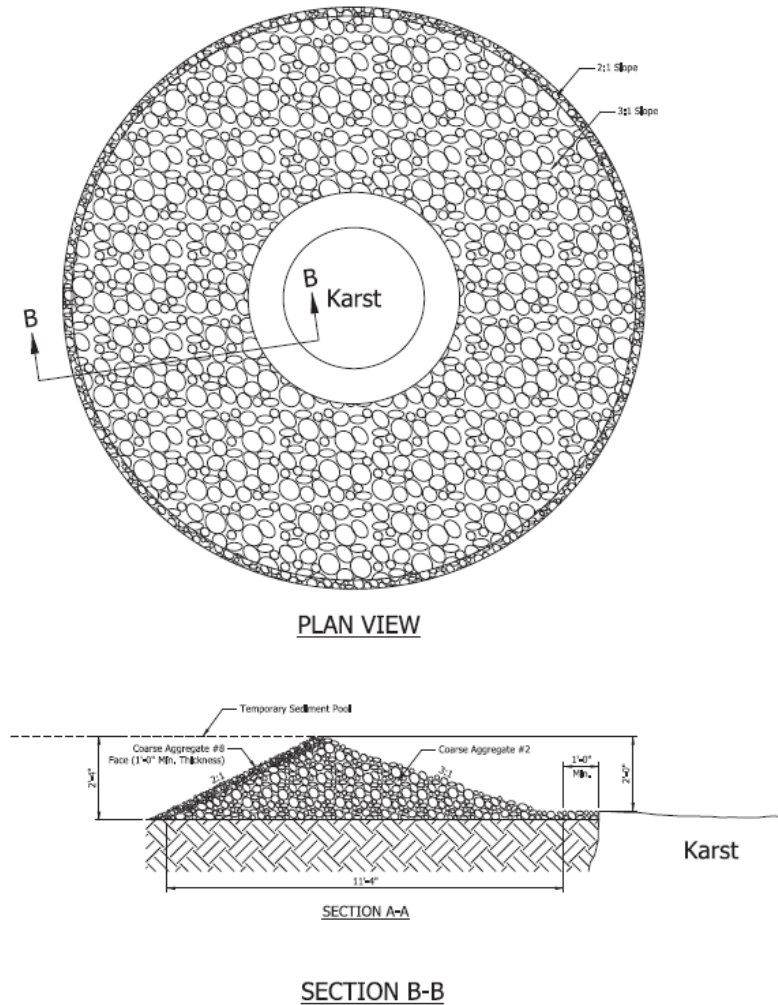

### C. Impact Mitigation

Karst mitigation is focused on maintaining the quality and quantity of water entering the feature. It includes permanent measures designed to reduce impacts resulting from the project. Mitigation measures include installing peat/sand/gravel filters, vegetative buffers, and lined spill/runoff containment structures, to detain or treat highway runoff prior to discharge. Mitigation measures are developed as part of the design process and may require coordination with federal, state and local governments. As permanent features they will require an asset number, maintenance plan and periodic monitoring and maintenance.



## D. Construction Mitigation Methods

Karst features are mitigated during construction to maintain water flow or to provide structural integrity for the overlying roadway. The location of the feature and direction of water flow will determine the appropriate mitigation measure. If the location is in the proposed roadway and the water flows through the feature into the underlying karst, it will be capped. If the feature located in the proposed roadway is a spring or seep, the mitigation method will maintain the flow of water from the underlying karst to the surface. The design of roadside ditches and other conveyances must ensure that the surface runoff has received adequate filtration prior to entering karst features located along the roadway. There are many methods used to mitigate karst features and a combination of techniques may be required.

- Excavation and plugging – This method is the most common mitigation method used to permanently seal a feature from surface flows. It is used for shallow sinkholes with a depth of 15 feet or less. All soil, rock and debris is removed from within the weak zones. The throat of the soil void is “capped” with concrete, grout, or a rock fill plug and backfilled or compacted to the desired density. Geotextile fabric is placed between the layers of stone and soil of an aggregate cap to prevent fines from entering the feature. A concrete cap is used when the sinkhole will be located under the roadbed to provide a permanent seal. This is a typical example of excavation and plugging.

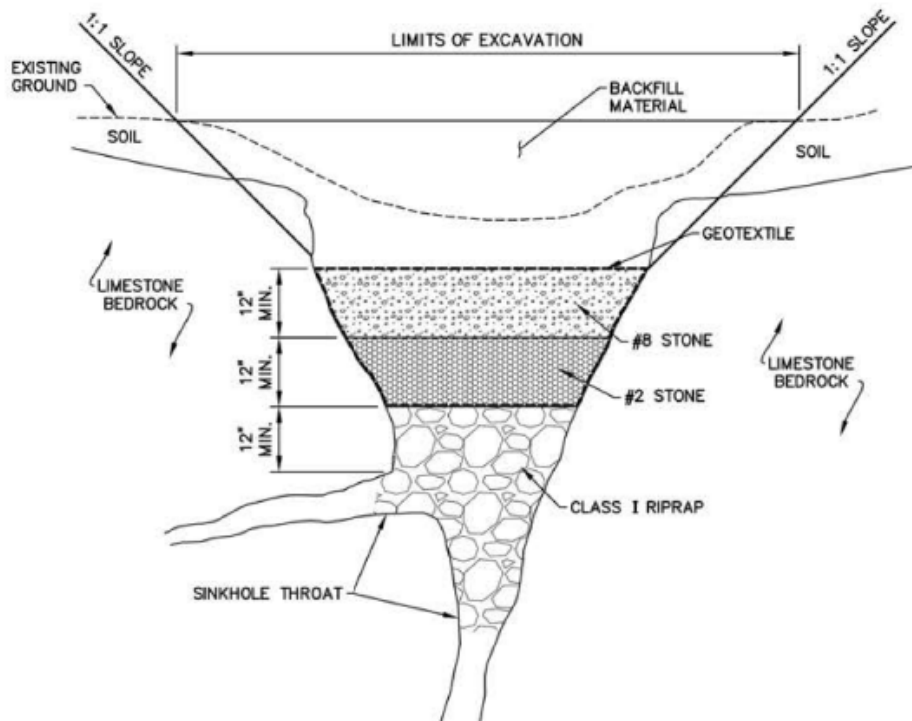

**Figure 15. Typical aggregate cap sinkhole treatment**  
Source INDOT

This design included the following notes:

1. Contractor shall perform exploratory excavations to determine extent of the sinkhole throat prior to installing the treatment.
2. All loose and fragmented rock, soil, trash and debris shall be removed from the excavation, down to the stable rock walls/surfaces at the sinkhole throat.
3. If during exploratory excavation, the sinkhole throat is determined to be greater than 36", Class II Riprap shall be used in lieu of Class I Riprap.
4. Contractor shall overlap the ends of the geotextile material a minimum of 24 inches.
5. Prior to placing concrete, all rock surfaces shall be free of soil and organic material.

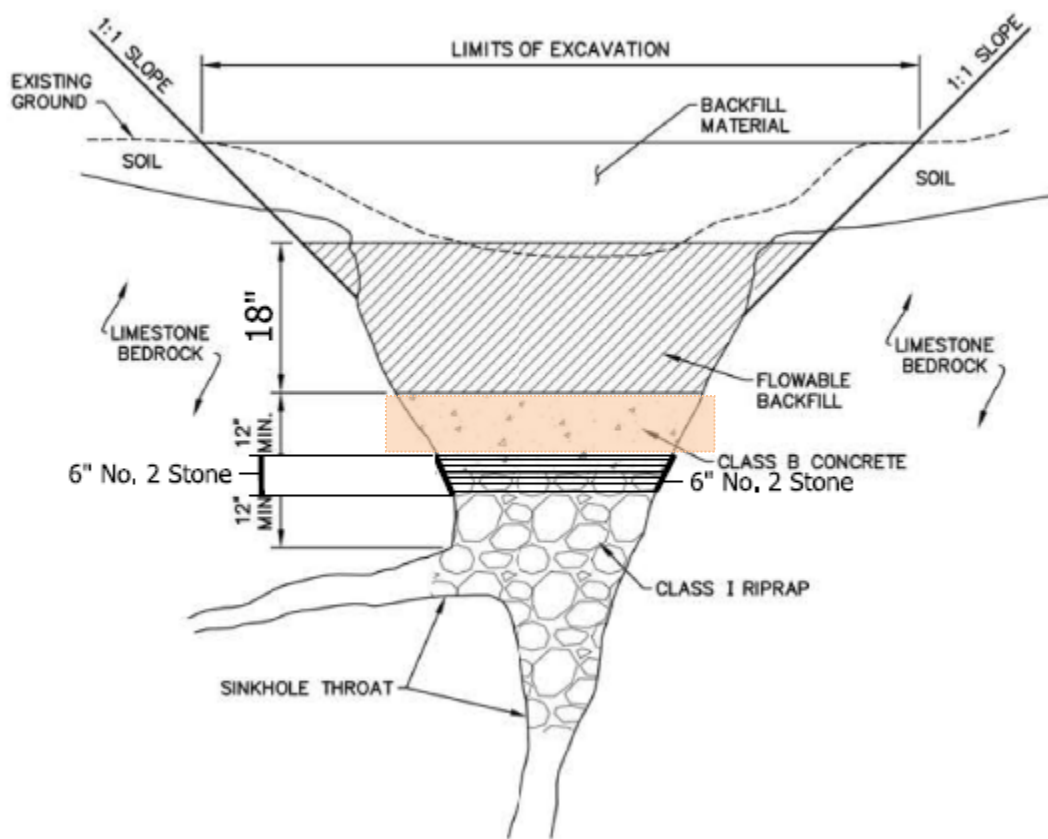
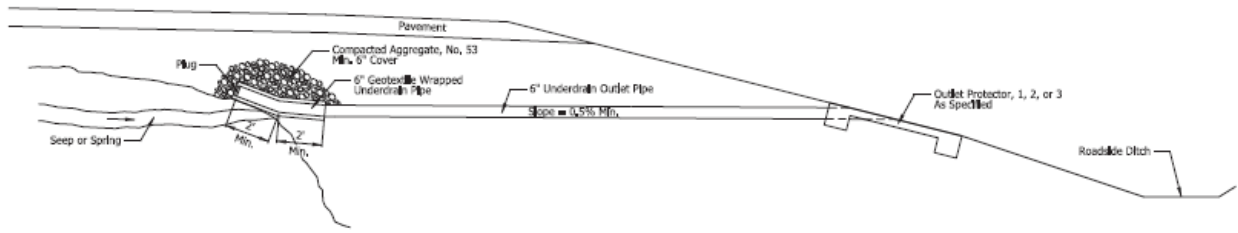

**Figure 16. Typical sinkhole treatment concrete cap**  
**Source INDOT**

NOTE – The slope at the concrete cap should be keyed to allow the cap to rest on the bedrock as illustrated by orange shaded area. This would limit future collapse of the cap into the feature.

- High/low mobility grouting – This method is used to permanently seal a feature. It consists of drilling to the karst voids and pumping high or low mobility grout





**Figure 18. Karst seep or spring outlet**  
Source INDOT

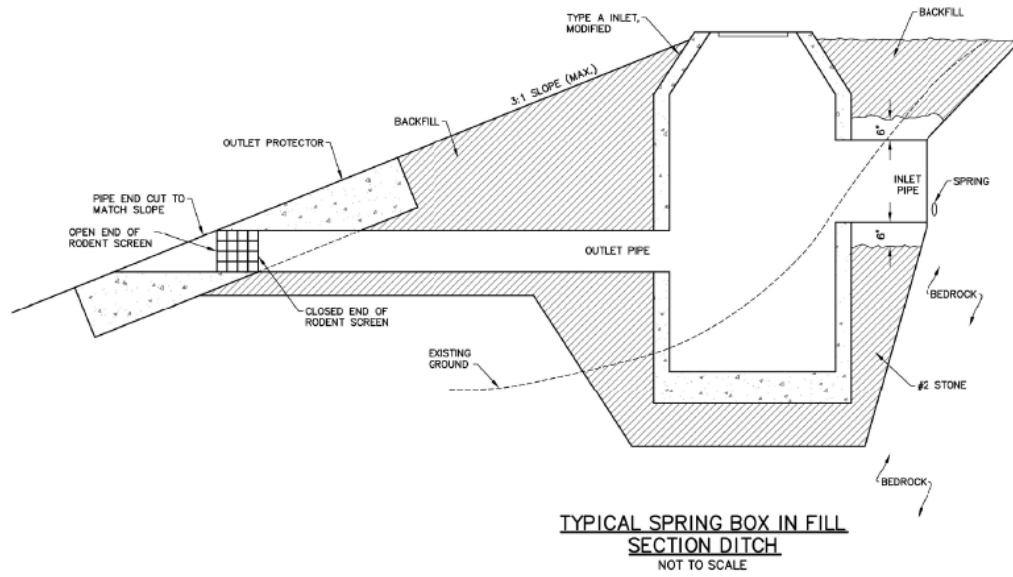

**Figure 19. Offset structure**  
Source INDOT

This offset structure is designed to allow water from the roadside ditch to flow into a sinkhole located under the embankment. The sinkhole is stabilized prior to installing the structure. The grate provides access for maintenance.



**Figure 20. Spring Box**  
Source INDOT

The spring box is designed to capture flow from a spring or seep located under fill and direct it toward the bottom of the slope.

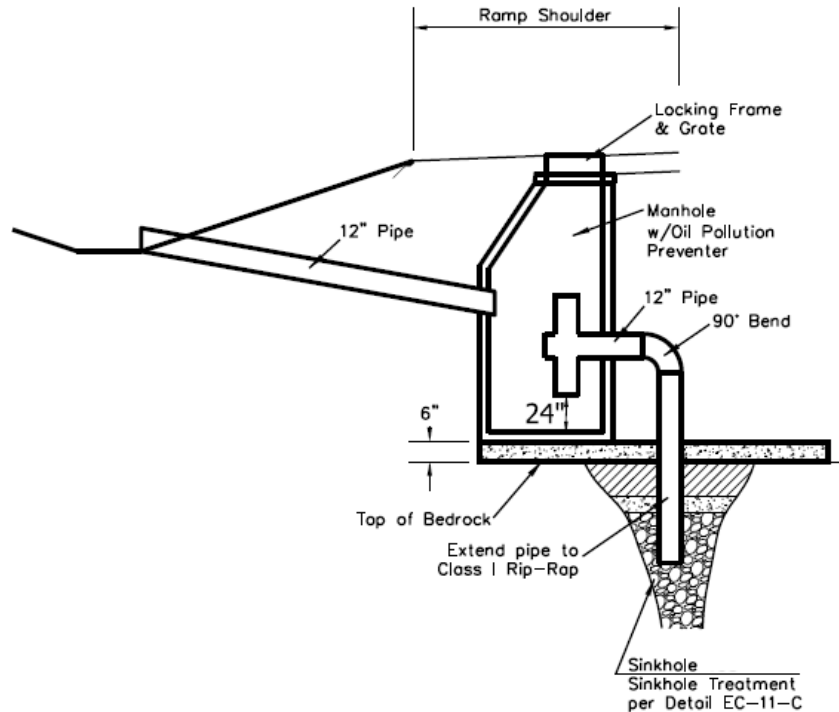

The construction of bridge piers within karst terrain requires that the pier footing be designed to the terrain. For example, spread footings are appropriate for locations with stable overburdens. Driven piles and caissons may also be used.

### **E. Post-Construction Mitigation**

IDEM's 2016 *Indiana Integrated Water Monitoring and Assessment Report* listed contamination from salt storage and road salting activities as a high priority risk factor. The risk factors associated with contamination from salinity/brine includes human health and/or environmental risk (toxicity), location of the source relative to the drinking water source, the number and/or size of contaminant sources, hydrogeologic sensitivity, and documented findings of contamination. Mitigation features along INDOT roadways are designed to keep contamination from salinity/brine out of adjacent karst features. This includes designation of no/low salt zones.

**Karst mitigation  
feature located along  
State Road 37 in  
Lawrence County  
Photo credit INDOT**



## Appendix A Terminology

**Aquifer** – A formation, group of formations, or part of a formation that contains enough saturated permeable material to yield significant quantities of water to wells and springs.

**Bedding plane** – A primary depositional lamination in sedimentary rocks separating two strata of differing characteristics.

**Best Management Practices (BMP)** – A body of land practices aimed at treating the watershed as a whole; used to control four primary, interactive processes: erosion, runoff, nutrient and pesticide or toxic controls.

**Contaminant (drinking water)** – Includes any physical, chemical, biological or radiological substance in water, including constituents that may not be harmful. (U.S. EPA)

**Dark zone** – Begins where the cave becomes completely dark and extends throughout the rest of the cave.

**Drainage basin** – The land area drained by a river and its tributaries; also called watershed or drainage area.

**Entrance zone** – The area just inside the cave opening. This area receives sun light that allows some plant growth and an exchange of animals that might also be seen living above ground.

**Epikarst (subcutaneous) zone** – A relatively thick (50 to 100 feet) portion of bedrock that extends from the base of the soil zone and is characterized by extreme fracturing and enhanced solution. It is the link between precipitation and in transport of water to deep aquifers.

**Graded filter** – A method for filling sinkholes in which the sinkhole's throat in the bedrock is covered with large pieces of stone. The layer of large stones is covered with a second layer of stones that are large enough to bridge the openings between the underlying stones. Layers of stone are laid down in courses until a final layer of fine gravel can be covered with soil and the surface can be graded.

**Groundwater basin** – The area throughout which groundwater drains toward the same point. It can be larger than the associated surface-water drainage basin if permeable layers extend outside of the topographical divide.

Karst – A geologic setting, generally underlain by limestone or dolomite, formed chiefly by the dissolving of rock, and characterized by sinkholes, sinking streams, other closed depressions, subterranean drainage, and caves.

Karst valley – A compound sinkhole, sinking valley, or other large karst depression from 300 feet to 60 miles in size.

Karst window – An unroofed section of a subterranean stream; a sinkhole at the bottom of which can be seen a subterranean stream.

Natural bridge – An intact segment of an otherwise collapsed cave.

Pirated/captured (basin, watershed, flow) – The process by which one stream or cave enlarges its drainage basin area by expanding into a neighboring drainage basin.

Sinkhole – A basin- or funnel-shaped hollow in limestone, ranging in a diameter from a few feet up to a 300 feet and in depth from a few to several hundred feet.

Sinkhole plain – Topographic plain on which most of the local relief is due to sinkholes and nearly all drainage is underground.

Sinking/losing stream – A surface-flowing stream that disappears underground.

Spring – Any natural discharge of water from rock or soil onto the surface of the land or into a body of surface water.

Stygobites – Water-based cave fauna adapted to live their entire life in the cave, cannot survive above ground and have adaptations to help them survive in the darkness of the caves. Examples include blind crayfish, blind cavefish, blind cave salamanders and cave shrimp.

Stygophiles – Water-based cave fauna they are preadapted to survive their entire life in a cave, but can also live in suitable above ground habitat. Examples include springfish and some salamanders.

Stygoxenes – Water-based cave fauna that spend much of their time above ground. They use the caves for a specific part of their life cycle. Includes surface dwelling stream animals such as fish, crayfish, and freshwater mussels.

Subterranean Systems Cave Entrance – Includes the surface openings and reaching as far as the natural light can penetrate (entrance and twilight zones).



Subterranean Systems Caves – Includes the connected underground rooms and passages beyond natural light penetration (dark zone).

Swallow hole/swallet – A place where water disappears underground into a hole in a stream bed or sinkhole.

Topographic divide – The boundary between two surface watersheds.

Troglobites – Cave fauna that are adapted to live their entire life in a cave. They cannot survive above ground and have adaptations to help them survive in total darkness. Examples include cave millipedes, some beetles, and cave spiders.

Troglophiles – Cave fauna found in the space above the water table that are preadapted to survive their entire life in a cave, but can also live in suitable above ground habitat. Examples include beetles, terrestrial crayfish, pigmented earthworms, millipedes, and centipedes.

Trogloxene – Cave fauna found in the space above the water table. They use the cave for a specific part of their life cycle, such as hibernation, nesting, or giving birth. Examples include bats, bears, crickets, foxes, pack rats, snakes, raccoons, moths, swallows, vultures, and groundhogs.

Twilight zone – The area farther from the entrance where the light begins to diminish.

Water table – The surface at the top of the groundwater, below which water completely fills the pore spaces of the rock.

## Appendix B References

- Currens, James C. “Kentucky Is Karst Country! What You Should Know About Sinkholes and Springs. Kentucky Geological Survey, Information Circular 4, 2002.
- Field, M. S. A Lexicon of Cave and Karst Terminology with Special Reference to Environmental Karst Hydrology (1999 Edition). U.S. Environmental Protection Agency, Office of Research and Development, National Center for Environmental Assessment, Washington Office, Washington, DC, EPA/600/R-99/006, 1999.  
<https://cfpub.epa.gov/ncea/risk/recordisplay.cfm?deid=12468&CFID=65388516&CFTOKEN=81082643>
- Frushour, Samuel S. A Guide to Caves and Karst of Indiana. Indiana University Press, 2012.
- Indiana Department of Environmental Management, “Proper Investigative Techniques in Karst.” Technical Guidance Document, June 30, 2011.
- Indiana Department of Environmental Management, “Indiana Integrated Water Monitoring and Assessment Report to the U.S. EPA,” [https://secure.in.gov/idem/nps/files/ir\\_2016\\_report.pdf](https://secure.in.gov/idem/nps/files/ir_2016_report.pdf) [accessed July 13, 2016]
- Indiana Department of Natural Resources (IDNR), “Subterranean Systems Habitat Summary.” <http://swap.dnr.IN.gov>
- Indiana Department of Natural Resources (IDNR), “Drilling Procedures to Protect Karst Resources.” May 7, 1988.
- Indiana Geological Survey website <https://igs.indiana.edu/Bedrock/Karst.cfm>
- The Indiana Geological Survey (IGS) has served the people of Indiana since 1837. Established in Indiana Statute in 1993 as an institution of Indiana University, the IGS is committed to providing unbiased and reliable earth science information through directed research, service, and education. The mission of the Indiana Geological Survey is to provide geologic information and counsel that contribute to the health, safety, and welfare of Indiana's citizenry. The IGS provides information for the wise stewardship and sustainable use of the energy, mineral, and water resources of the state while enhancing the natural environment.
- Indiana Karst Conservancy website <http://www.ikc.caves.org/>
- The Indiana Karst Conservancy is a non-profit organization dedicated to the preservation and conservation of Indiana's unique karst features. The IKC was formed by concerned individuals when it was apparent that no similar group was actively protecting the features for their geological, biological and archeological importance. The purposes of the IKC are the

management, protection and acquisition of the karst areas in Indiana. The IKC also supports research and promotes education related to karst and its appropriate use.

Taylor, Charles J. and Earl A. Greene, “Hydrologic Characterization and Methods Used in the Investigation of Karst Hydrology” in Rosenberry, D.O., and LaBaugh, J.W., 2008, Field Techniques for Estimating Water Fluxes Between Surface Tension Water and Ground Water. Techniques and Methods 4–D2, U.S. Department of the Interior, U.S. Geological Survey. <http://pubs.usgs.gov/tm/04d02/>

United States Geological Survey, USGS Groundwater Information, Karst Website  
<http://water.usgs.gov/ogw/karst/>

## Appendix C

### Karst Memorandum of Understanding (MOU)



## **Memorandum of Understanding**

**(Retyped of original text 3/14/2007)**

This Memorandum of Understanding is made and entered into this thirteenth day of October, 1993, between the Indiana Department of Transportation (INDOT), the Indiana Department of Natural Resources (IDNR), the Indiana Department of Environmental Management (IDEM) and the U.S. Fish and Wildlife Service (USFWS) for the purpose of delineating guidelines for construction of transportation projects in karst regions of the State.

**Whereas**, INDOT, IDNR, IDEM and the USFWS wish to cooperate in the identification, study and treatment of drainage in karst regions related to the construction of transportation projects and

**Whereas**, INDOT, IDNR, IDEM and the USFWS accept responsibility to ensure the transportation needs of Indiana are met in an environmentally sensitive manner that protects the habitat of all species and

**Whereas**, design and construction practices must protect ground water quality, public health and safety, and the environment.

**Whereas**, the Indiana Department of Natural Resources will conform to the terms and conditions within this MOU for their transportation projects. Likewise, it will be IDNR's responsibility to provide standard biological review for projects in the karst region.

**Therefore**, in consideration of the terms and conditions set forth herein the INDOT, IDNR, IDEM and USFWS agree as follows:

1. INDOT in cooperation with the IDNR, IDEM and USFWS shall determine the location of sinkholes, caves, underground streams, and other related karst features and their relationship prior to proposed alterations or construction in karst regions of the state, a consultant with expertise in karst geology/hydrology may assist in the identification and characterization of the karst features. The choice of the consultant retained by INDOT will be subject to the review of IDNR, USFWS and IDEM.
2. Tasks to accomplish this work will include:
  - Research public and private information sources for information relative to karst features.
  - Conduct field check karst and cave features that appear from the first task and identify any additional karst features.
  - Prepare a draft report, with photographs and maps, drainage areas, and land use of that drainage area for each sinkhole or karst feature, dye-tracing and/or other geotechnical information to determine subsurface flow of water in the project area

and surface water drainage patterns of the area. Calculations of estimates of annual pollutant loads from the highway and drainage with the right-of-way will be made, including prior to, during and post construction estimates. The design of the treatment of the karst features will take into consideration treatments necessary to meet the standards of the monitoring and maintenance plan.

That report will be used as a tool to assist in determining the proposed highway alignment. The intent of INDOT is to avoid karst areas and use alternate drainage where possible.

3. IDNR, IDEM and USFWS will be requested to review and comment on the findings at the early coordination phase of project development.
4. INDOT, using the input from IDNR, IDEM and USFWS will begin to formulate appropriate measures to offset unavoidable impacts to the karst features. It is understood by all parties that some of the methods proposed at this time will be generic and could be applied throughout the length of the corridor. Other methods may be specific to a particular cave or karst feature. Some of the approaches may require additional investigations to determine their necessity and/or their feasibility. A revised draft report will be prepared by INDOT's consultant and provided to the IDNR, IDEM and the USFWS as part of the design review process.
5. Drainage entering from beyond the right-of-way will be treated according to the same process as drainage generated by the project.
6. As the project progresses further into the design phase, the IDNR, IDEM and USFWS will be invited and will attend field checks and meetings dealing with efforts to negate or minimize adverse impacts.
7. Hazardous materials traps (HMT's) will be constructed at storm water outfalls and other locations that will protect karst features from spill contamination.
8. INDOT agrees to develop a monitoring and maintenance plan for the affected karst features. IDNR, IDEM and USFWS will be provided an opportunity to review this plan. The establishment of water quality and a point at which a standard is established for remediation will be a part of each monitoring plan. The results of the monitoring will be submitted to IDNR, USFWS and IDEM on a regular basis.
9. A low salt and no spray strategy will be developed for each future project. A signing strategy for these items will also be developed for each project.
10. Prior to acceptance of the final design plans an agreement will be developed which will set out the appropriate and practicable measures to offset unavoidable impacts to karst features. This agreement will be signed by the Department Director of IDNR, the Commissioner of the IDEM, the Commissioner of INDOT and the Supervisor of the USFWS Bloomington, Indiana Field Office. The agreement will become a part of

the contract documents for the project, will be discussed at the pre-construction conference and will be on file at the office of the project administrator.

11. INDOT will assure that the terms of the agreement will be completed with all safeguards given to the karst area. Special provisions, which are binding provisions that are a part of the contract, will be included outlining the precautions to be taken. Construction and design strategies for handling karst features will be discussed with the contractor(s) and project administrator during the pre-construction conference. Project administrator shall ensure that the contractor is following the new erosion control standards that meet Rule 5 of 327 IAC 13 and any special precautions outlined in the design plans that the sinkhole treatment is being handled correctly. The erosion control plan must be available at the project administrator's office. An emergency response plan will be made a part of the contract documents. In addition, the contract documents will contain a strategy for signing to alert the public to the fact that all types of spills are potentially hazardous to the karst environment. For INDOT, this plan would be procedure 20 of the Field Operations Manual dated 6/24/1992. [Currently in the Construction Activities Environmental Manual].
12. The location and nature of the sinkholes and drainage schematic will be provided to the IDEM. They will provide the information to the appropriate local authorities and the Hazmat teams. An emergency response plan will be followed. This constitutes procedure 20. Included in this information is an understanding that all types of spills are potentially hazardous to karst regions.
13. IDNR, IDEM and USFWS personnel will monitor construction and maintenance to the agreed upon terms, as deemed necessary.
14. If during construction it is found that the mitigation agreement must be altered, all of the agencies will be contacted and agreement reached prior to work continuing in that specific area of the project. In order to not unduly delay projects, a two working days response time is needed from the resource agencies.
15. Treatments will be maintained during construction by means of a visual inspection on a weekly basis or after every rain. Corrective action will be taken as needed.
16. If after the above procedure is followed and a state/federal endangered/threatened species is found during construction, work in that area of the project will stop. The IDNR and USFWS will be immediately notified. The IDNR and USFWS will promptly investigate the situation, advise the project administrator and assume responsibility for protecting the endangered species and taking the appropriate action.
17. This document will be reviewed annually or more frequently at the request of any of the foregoing agencies.

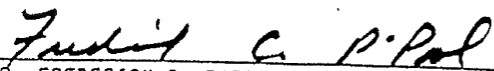
  
MR. FREDERICK C. P'POOL, COMMISSIONER  
INDIANA DEPARTMENT OF TRANSPORTATION

  
MR. PATRICK R. RALSTON, DIRECTOR  
INDIANA DEPARTMENT OF NATURAL RESOURCES

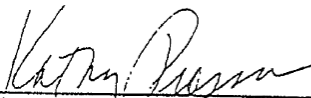
  
MS. KATHY PROSSER, COMMISSIONER  
INDIANA DEPARTMENT OF ENVIRONMENTAL MANAGEMENT

  
MR. DAVID C HUDAK, FIELD SUPERVISOR, BLOOMINGTON FIELD OFFICE  
U. S. FISH AND WILDLIFE SERVICE

Appendix D  
Karst Standard Operation Procedure



## A. Karst Investigations during NEPA

1. When a construction project is located in areas with the potential for karst features, the karst MOU in Appendix C must be followed.
2. The karst MOU identifies a “Potential Karst Features Region,” but karst features will be found outside of this area.
3. If a project requires a karst investigation, it should be done through the NEPA or design contract. If the NEPA or design firm does not have access to a pre-qualified consultant, the Ecology and Waterway Permitting Office (EWPO) on-call karst consultant can be used. The Team Lead assigned to the district will help set this up. The pre-qualified consultant will be familiar with the MOU and the procedures that must be followed. The funding will come from the NEPA or design budget.
4. The karst report will be reviewed by the district EWPO specialist, who will submit the approved report to USFWS, IDNR and IDEM for their review.
5. Following agency review, the final report should be used by the designer and project consultants to incorporate remedial action into the design plans. The report will include a monitoring plan and mitigation recommendations, such as sink hole capping or other treatment, construction BMPs, hazardous material measures, or low salt - no spray areas.
6. The location of karst features, hazardous material measures and drainage patterns should be provided to area emergency response authorities.
7. Local Public Agencies are not bound by the MOU. However, following the process may help identify karst features early in the design process.

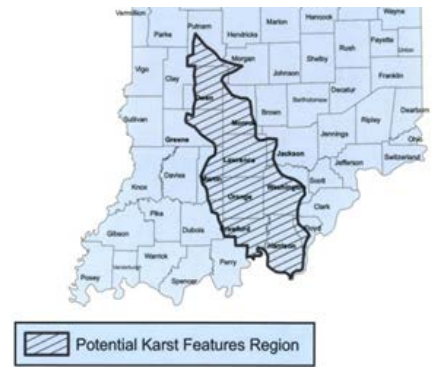

## B. Accidental Karst Discovery

1. If a karst feature is discovered within existing right-of-way, the district maintenance staff should evaluate the feature to determine if protection measures are necessary.
  - a. For example, if the feature is a hazard to the roadway, it has the potential to undermine the roadway or make it unstable and it should be stabilized.
  - b. For example, if mitigation may be required to protect the feature, installation of an aggregate cap to prevent unfiltered runoff water from entering the feature or consultation with a licensed geologist may be required.
2. If assistance is required from the EWPO on-call karst consultant, contact the Team Lead assigned to the district. Provide location and aerial maps and photos of the feature and surrounding area. The Team Lead will coordinate with the consultant.
3. If no mitigation is required, monitor the feature for stability.
4. The consultant will evaluate the site and provide mitigation recommendations through a karst report.
5. The EWPO will coordinate with the agencies as required.

## Appendix E

### DNR Subterranean Systems Habitat Summary



# SUBTERRANEAN SYSTEMS

## HABITAT SUMMARY



*Surface openings of subterranean features reaching as far as natural light can penetrate (i.e., twilight zone) and connected underground rooms and passages beyond natural light penetration. This habitat encompasses the following sub-types: caves and cave entrances.*



*Subterranean Systems - the karst region of Indiana is predominantly located in the south-central part of the state.*

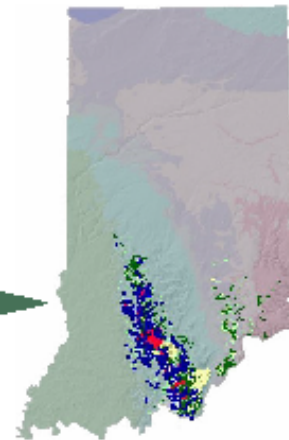

## Indiana's State Wildlife Action Plan

### Representative Species of Subterranean Systems

The Subterranean Systems habitat guild is represented by several species. These representative species “paint a reasonable mental picture” of subterranean systems.

Eastern Pipistrelle  
Longtail Salamander

Indiana Myotis  
Four-Toed Salamander

Cave Salamander  
Northern Cavefish



From left to right: *Eastern pipistrelle, northern cavefish and cave salamander*

### Species of Greatest Conservation Need (SGCN) in Subterranean Systems

SGCN are animal species whose populations are rare, declining or vulnerable.

Green Salamander  
Gray Myotis  
Eastern Pipistrelle  
Southeastern Myotis

Four-toed Salamander  
Indiana Myotis  
Little Brown Myotis

Northern Cavefish  
Rafinesque's Big-eared Bat  
Northern Myotis



From left to right: *Indiana bats and green salamander*

[swap.dnr.IN.gov](http://swap.dnr.IN.gov)



## Indiana's State Wildlife Action Plan

### Threats to Subterranean Systems

- Habitat degradation
- Climate change
- Residual contamination (persistent toxins)
- Habitat fragmentation
- Mining/acidification
- Commercial or residential development (sprawl)
- Agricultural/forestry practices
- Point source pollution (continuing)
- Nonpoint source pollution (sedimentation and nutrients)
- Drainage practices (stormwater runoff)

### High-Priority Conservation Actions for Subterranean Systems

#### Technical assistance

- Develop educational materials for landowners in karst topography about relationships between surface activities and subterranean systems.

#### Cooperative land management agreements (conservation easements)

- Promote the use of cooperative land agreements to protect sensitive karst features for green salamanders, four-toed salamander and subterranean systems that support northern cavefish and bat species of greatest conservation need.

#### Restrict public access and disturbance

- Post signs at important cave sites to reduce/eliminate unauthorized human visitation.
- Erect physical barriers (i.e., fences, gates) where needed to protect important cave sites.

#### Land-use planning

- Identify surface recharge areas for cave systems to identify sources of potential threats.

#### Habitat protection on public lands

- Develop land management plans protective of subterranean systems and permit recreation use consistent with the conservation of SGCN.

#### Habitat protection through regulation

- Support regulations relative to cave closures to protect bat SGCN, especially the Indiana myotis.
- Provide technical assistance to regulatory programs regarding subterranean systems beneficial to SGCN for evaluation of projects conducted under state permit or receiving public funds.

#### Habitat restoration on public lands

- Determine and support development of beneficial habitat conditions to be maintained near surface openings (e.g. cave entrances, sinkholes, rises) to subterranean systems.

#### Protection of adjacent buffer zone

- Protect woodland buffers surrounding cave entrances to provide habitat for the green salamander.
- Determine effective size of forested buffer around caves used as hibernacula by Indiana bats and other cavernicolous SGCN.
- Provide vegetative buffer strips/zones around sinkholes.

#### Pollution reduction

- Identify surface recharge areas.
- Provide adequate filter and buffer strips around input sources to cave systems.

#### Corridor development/protection

- Identify all cave-system openings and karst stream (Lost River) tributaries and promote the protection of the entire system.

#### Adaptive Management

- Modify survey and monitoring, research and other conservation actions and activities in response to new information to improve habitat conservation efficiency for SGCN.



## Indiana's State Wildlife Action Plan

### Threats to SGCN in Subterranean Systems

- Habitat loss (breeding range)
- Habitat loss (feeding/foraging areas)
- Specialized reproductive behavior or low reproductive rates
- High sensitivity to pollution
- Bioaccumulation of contaminants
- Degradation of movement/migration routes (overwintering habitats, nesting and staging sites)
- Unintentional take/ direct mortality (e.g., vehicle collisions, power line collisions, by catch, harvesting equipment, land preparation machinery)
- Small native range (high endemism)
- Dependence on irregular resources (cyclical annual variations) (e.g., food, water, habitat limited due to annual variations in availability)
- Predators (native or domesticated)

### High-Priority Conservation Actions for SGCN in Subterranean Systems

#### Habitat protection

- Protect wet areas around seeps and springs for the benefit of four-toed salamanders.
- Protect the water quantity and quality in subterranean streams to benefit northern cavefish populations.
- Inventory subterranean systems cave-dependent SGCN such as the Indiana bat and southeastern bat.
- Restrict human access to caves during seasonal use by Indiana bats and other cave-dwelling species. Erect physical barriers (gates, fences) as needed.

#### Regulation of collecting

- Provide public notification materials throughout the karst region of Indiana regarding the adverse consequences of collecting or disturbing subterranean system SGCN.

#### Threats reduction

- Investigate the threats (e.g. pesticides, water level changes, soil erosion, human disturbance) to subterranean system SGCN.

#### Public education to reduce human disturbance

- Erect interpretive warning signs at entrances to important cave sites to discourage human entry.

#### Limiting contact with pollutants/contaminants

- Investigate sinkhole buffer systems to minimize the adverse impacts of runoff into subterranean systems from surrounding lands on SGCN.
- Investigate the impact of smoke and other air quality problems on subterranean system SGCN.

#### Adaptive Management

- Modify survey and monitoring, research and other conservation actions and activities in response to new information to improve conservation efficiency for SGCN.



[swap.dnr.IN.gov](http://swap.dnr.IN.gov)