

Septic Permit Application

CARROLL COUNTY HEALTH DEPARTMENT

KEVIN FESLER

STEPS TO GET A SEPTIC PERMIT

1. Obtain a soil report of the area of the proposed septic system (Information Attached).
 - a. Select a soil scientist. A list of soil scientists who do a lot of work in Carroll County is attached.
 - i. These soil scientists are knowledgeable in the geology of Carroll County and will be able to assist you in the selection of a location on your property that is likely to work well for a septic system.
 - ii. The soil scientist will submit a copy of the results of the soil tests to the Carroll County Health Department.
2. The Health Department will provide a specification sheet after receiving the soil reports and send it to you and your contractor if you have already selected one.
3. The contractor will submit the application with a drawing of proposed system to the Health Department.
4. The information will be reviewed by the Health Department.
 - a. Any alterations required to be in compliance with the Residential On-Site Sewage System Rule 410 IAC 6-3-8 will be discussed with the contractor and the plan will be revised as necessary
5. Pay Fee:
 - a. Septic system repair - \$ 75.00.
 - b. New Septic System - \$ 100.00.
6. System approved and a permit will be issued.

ADDITIONAL INFORMATION

OBTAIN A SOIL EVALUATION FROM A CERTIFIED SOIL SCIENTIST--A LIST IS AVAILABLE FROM THE HEALTH DEPARTMENT [attached].

UPON RECEIPT, THE HEALTH DEPARTMENT SANITARIAN WILL EVALUATE THE PERMEABILITY OF THE SOIL, DETERMINE THE REQUIRED SQUARE FOOTAGE OF THE ABSORPTION FIELD BASED ON THE NUMBER OF BEDROOMS, TRENCH DEPTH, AND PERIMETER DRAIN REQUIREMENTS AND DEVELOP A MINIMUM SPECIFICATION FOR YOUR NEW SYSTEM.

DEVELOP A PLAT PLAN TO SHOW THE LOCATION OF THE RESIDENCE, RESIDENCE WELL, DRIVEWAY, OTHER BUILDINGS, PROPERTY LINES, AND THE PROPOSED LOCATION OF THE SEWAGE SYSTEM. THE SYSTEM SHOULD BE LOCATED IN THE VICINITY OF THE SELECTED SOIL BORING AND THE AREA STAKED OUT TO PREVENT CONSTRUCTION TRAFFIC FROM COMPACTING THE SOIL.

SELECT AN INSTALLATION CONTRACTOR WHO, UTILIZING THE PLAT PLAN , WILL DEVELOP A SYSTEM DESIGN THAT WILL SHOW THE LOCATION OF BENCHMARK, SPOT ELEVATIONS AND LAND CONTOURS, SLOPE OF ABSORPTION FIELD SITE, LOCATION OF ALL SOIL BORINGS, LOCATION AND ELEVATION OF ALL SYSTEMS COMPONENTS. THE HOMEOWNER/CONTRACTOR WILL SUBMIT THE PLAT PLAN, APPLICATION, AND SYSTEM DESIGN ALONG WITH THE FEE TO THE HEALTH DEPT FOR REVIEW AND APPROVAL/ DISAPPROVAL. IF APPROVED, THE HEALTH DEPARTMENT WILL ISSUE A PERMIT.

REPAIR FEE \$75.00

NEW PERMIT \$100.00

THE CONTRACTOR MUST NOTIFY THE HEALTH DEPARTMENT AT LEAST 24 HOURS IN ADVANCE OF COMMENCING INSTALLATION TO ALLOW FOR SCHEDULING REQUIRED INSPECTIONS. THE HOMEOWNER IS RESPONSIBLE FOR INSURING THAT GRASS IS PLANTED OVER THE SYSTEM TO PREVENT EROSION.

Updated 11/23

Carroll County Health Department
APPLICATION FOR A RESIDENTIAL ON-SITE SEWAGE DISPOSAL SYSTEM PERMIT

Date _____ Applying for: New System ___ Repair ___ Expansion ___

Site Address: _____ Twp _____ Parcel # _____

Directions to site: [if address is not available] _____

Applicant _____ Telephone _____

Address _____ E-mail _____

Property Owner [If different from applicant] _____ Telephone _____

Address _____ E-mail _____

Soil evaluation conducted by: _____ Telephone _____

Site Description:

Attach a floor plan of the proposed building clearly indicating which rooms will be used as bedrooms.

Attach a scale site plan indicating the location of the buildings, soil borings, drain field (including fingers), septic tank, distribution box, well, perimeter drain, perimeter drain outlet,

Water Supply: Public ___ Semi Public ___ Private ___

Water Softener: Yes ___ No ___ Jetted Bathtub Capacity > 125 g: Yes ___ No ___

Number of Bedrooms or bedroom equivalents _____

Several inspections will be conducted as part of the installation of the on-site sewage system. By signing this application, you agree to allow Carroll County Health Department staff to enter your property without further notification for all inspections required to install your on-site sewage system.

By signing this document, the property owner and/or his agent certifies that to his knowledge, all the information submitted is correct and the system will be installed as approved in compliance with 410 IAC 6-8.1 and local ordinance 89-4 Code 3-49 of Carroll County.

NOTE: A floor plan of the proposed building and scale drawing of the site are required before a permit is issued.

Applicant Signature: _____

CCHD Use Only:

Date _____ Site is: Approved _____ Denied _____

By: Carroll County Environmental Sanitarian: _____

Carroll County Health Department Gravity & Flood Dosed System Design Sheet for Subsurface On-Site Sewage System

(To be attached to the site plan drawing)

Site Location: _____ Parcel Number: _____

Installer Name: _____ Installer Phone Number: _____

(Circle or fill in the correct item on each line)

Septic Tank: Size; 750 1000 1250 1500 1750 Manufacturer; Carter Rensselaer Other _____

Construction Material: Concrete Polyethylene Compartments: One Two

Filter: Yes No Filter Alarm: Yes No

Distribution Box: Holes: _____ Manufacturer; Carter Rensselaer Other _____

Construction Material: Concrete Polyethylene

Gravity & Effluent Sewer Pipe: Size: 4" 6" Type: [PVC] ASTM D2665 ASTM F891 ASTM D3034

[ABS] ASTM D2661 ASTM D2680 ASTM D2751

Dose Tank: N/A Size; 1000 g Other _____ Manufacturer; Carter Rensselaer Other _____

Construction Material: Concrete Polyethylene

Effluent Pump: N/A Yes No Total Head: _____ Discharge Rate: _____ Manufacturer: _____

Force Main: N/A Size; 1" 1.25" 1.5" 2" Other _____ Construction Material: ASTM D1785

Lateral Pipe: Total Length to be installed: _____ ft. Material Type: [PVC] ASTM D2729 [POLY] ASTM F810-85
AASHTO M252-Type SP

Trench Type: Gravel Infiltrator Chamber Other _____ Trench Fill; Stone Gravel Spec 20 Sand

Barrier Material: Geotextile Filter Fabric Brand; _____

Perimeter Drain: Not Required Required Size: 4" 6" With Sock Without Sock

Indicate type of system to be installed. [Sand line systems are on the reverse side.]

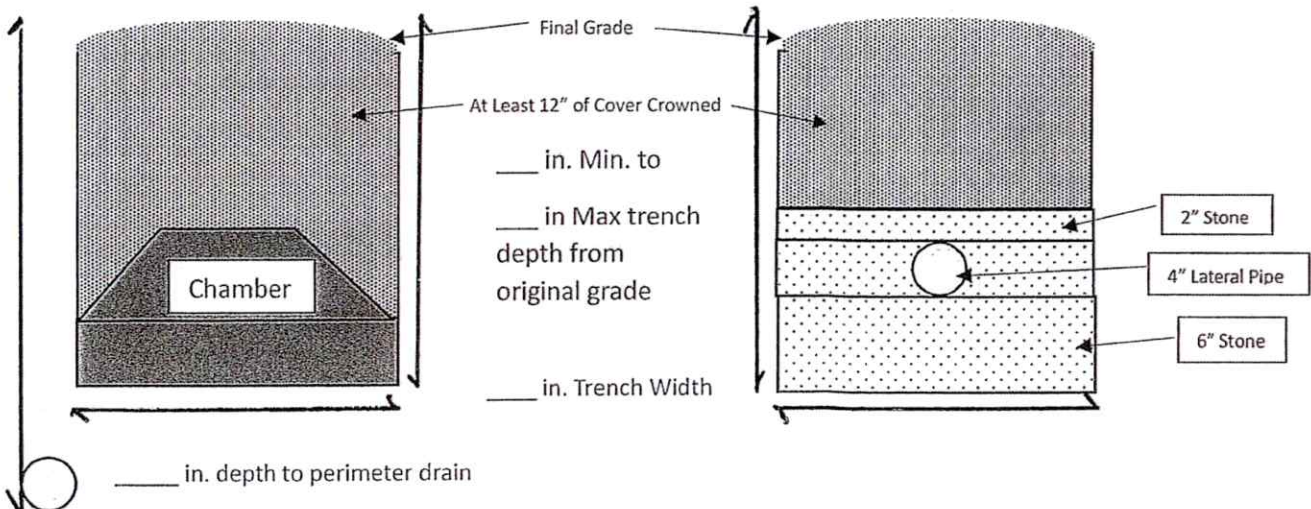

Contractor's Signature: _____

CHOOSE CROSS-SECTION THAT APPLIES AND PROVIDE REQUIRED INFORMATION

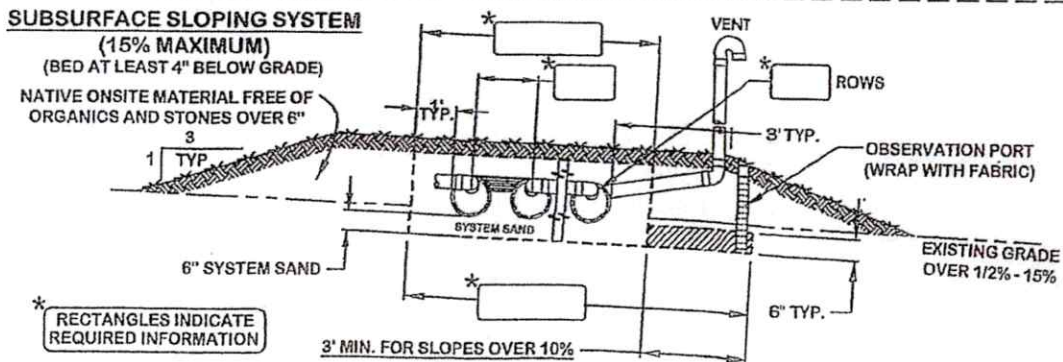
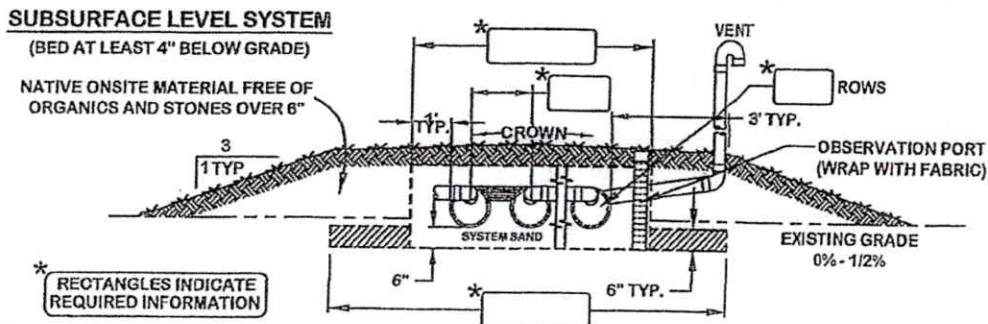
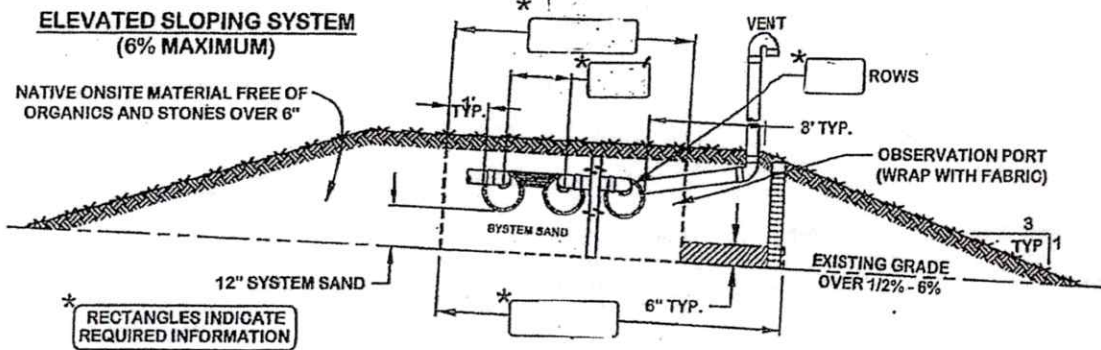
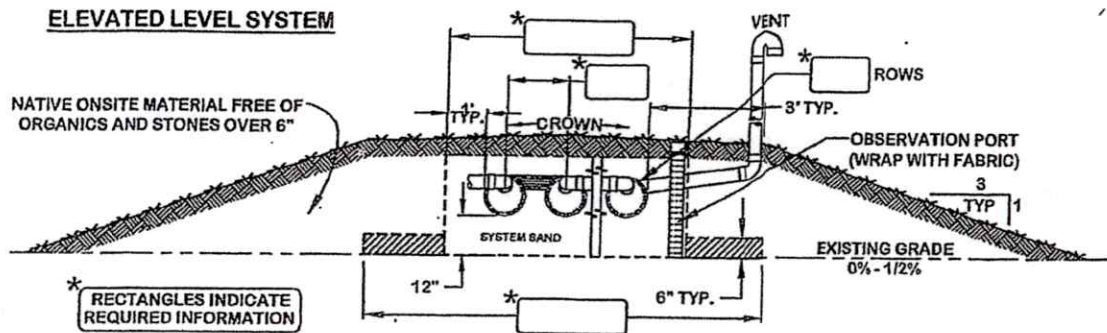

Soil Scientists						
Company	Name	Address	City	Zip	Phone	Email
GSH Soil Consulting	Gary Hudson	13030 N 225 E	Macy	46951	(765) 863-0431 (574) 382-5707	garyhudson@yahoo.com
Horizons LLC	Mark McClain	10740 Cheryl Ct.	Carmel	46033	(765) 212-7945	mmclain1313@gmail.com
Mosher Soil Consulting	JoAnn Mosher	10387 N 100 W	Monon	47959	(219) 253-8491	jomosher@holycowfarmfresh.com
Ziegler Soil Consulting, Inc.	Tom Ziegler	42 Canyon Creek Circle	Lafayette	47909	(765) 474-3041	thomasziegler@aol.com
Wamsley Soil Consulting	Ron Wamsley	1454 S 1000 W	Rensselaer	47978	(219) 869-5837	wamsronsin@yahoo.com
See the Indiana Registry of Soil Scientists for additional listings: oisc.purdue.edu/irss/index.html						
Well Drillers						
Company	Name	Address	City	Zip	Phone	Email
Armstrong Drilling		1480 Michigan St	Burlington	46915	(765) 566-3362	
Dilden Brothers		1426 Canal St.	Lafayette	47904	(765) 742-1717	
Findlay Well Drilling		1200 SR 25	Lafayette	47909	(765) 474-1383	findlaydrilling.com
Moss Well Drilling		201 E North St.	Galveston	46932	(574) 699-6773	mosswelldrilling.com
Ortman Drilling		241 N 300 W	Kokomo	46901	(765) 459-4125	
Titus Well Drilling, Inc	Vaughn Titus	2706 State Rd 225 E.	Battleground	47920	(765) 567-2516	judy@tituswelldrilling.com
Pumpers						
Company	Name	Address	City	Zip	Phone	Email
American Pumping		2522 E SR 218	Camden	46917	(765) 427-8877	americanpumpingenviro.com
Godlove Enterprises Inc.		933 Hanawalt Rd.	Monticello	47960	(574) 586-8990	godloveent.com
Snow White		3304 W 250 N	Lafayette	47909	(765) 463-9100	snowwhiteservices.com
Septic Installation and Repair Contractors						
Company	Name	Address	City	Zip	Phone	Email
AAA Sewer & Drain Cleaning	Jim Henson	1997 E 225 N	Winamac	46996	(574) 946-1036 (574)242-8297	aaaseweranddraincleaning@gmail.com
Alan George Excavating	Alan George	11329 W 250 N	Delphi	46923	(765) 564-2451	www.alangeorgeexcavating.com
Alliance Excavating and Demolition Inc.		6454 S 750 W	Russiaville	46979	(765) 883-1172	
Cable Excavating, LLC	Mark Cable	4313 E 200 S	Bringinghurst	46913	(574) 967-4211	cable.andrea@gmail.com
Cheesman Inc.	Gary L. Cheesman	5008 Washington St.	Westpoint	47992	(765) 572-2550	gary@cheesmaninc.com
Cole and Sons, Inc.		7851 W 220 S	Russiaville	46979	(765) 883-7950	www.coleandsonsin.com/
Coomler Contracting	Tim Coomler	657 W 400 S	Cutler	46920	(765) 860-5635	coomlercontracting@gmail.com
County Line Tile		9118 W 1000 S	Winamac	46996	(574) 278-7484 (765) 860-5635	
Deaton	Kyle Deaton	5368 S 800 W	Delphi	46923	(765) 430-9699	

Dehaai Construction	Jerry Dehaai	4710 W 775 S	Rossville	46065	(765) 379-3229	
Dutcher Trenching	Josh McCloud	805 Kentucky St.	Crawfordsville	47933	(765) 362-3306	dutchertrenching@gmail.com
ESL Enterprises LLC		7124 N 500 W	Mulberry	46058	(765) 202-2757	ESLENTLLC@gmail.com
Fisher Excavating		4919 Serum Plant Rd.	Thorntown	46071	(765) 426-8615	fisherexcavatingllc@gmail.com
Five Star Sewer & Septic Contractor	Rick DeGraff	2779 E 100 S	Kokomo	46902	(765) 452-1111 (765) 776-1538	fivestarseptic74@gmail.com
G and S Excavating	Dennis Sparks	725 W Fisher St.	Monticello	47960	(574) 870-4289	gandsexcavating@gmail.com
Geiser Excavating	Andy	5669 E 325 N	Camden	46917	(765) 412-1768	
Hack Excavating Inc.	John Hack	3700 S 175 W	Lafayette	47909	(765) 477-6734	www.hackexcavating.com/
Hass Excavating			Delphi	46923	(765) 637-3199	tristahaasexllc@gmail.com
Hylton Septic Systems	Evan Hylton	5782 E 750 N	Logansport	46947	(574) 859-2129 (765) 860-1091	hyltonenterprises@outlook.com
Ikes Sewer Service	Bill Banks	1950 E 800 N,	West Lafayette	47906	(765) 448-1443	www.ikesewerservice.com/
KHI	Brian Keene	635 Ferry St.	Lafayette	47901	(765) 427-5544	brian@keenehomesinc.com
K & L Myers LLC	Kyle Myers	3797 Richards Rd.	Morgantown	46160	(317) 775-0339	kmyers@klmyersllc.com
Kyburz Excavating		300 Walnut St	Monon	47959	(219) 253-7692	
Ladd Agricultural Services	Austin Ladd	2681 W 575 S	Cutler	46920	(765) 202-3070	austinladd454@gmail.com
Lowery	Jason Lowery	3175 N 900 W	Delphi	46923	(765) 202-1799	
M.L. Excavation and Demolition	Tyler Miller	7422 W 300 S	Delphi	46923	(765) 427-0784	tyler@mcexcdemo.net
P. E. Industries	Matt Bugher	115 Pineview Lane	Lafayette	47905	(765) 714-2271	mbugher@gmail.com
Poysel Construction	Jerry Beck	5845 Poinsettia Dr.	Lafayette	47905	(765) 447-6790	www.poyselconstruction.com/
Owens Sewer Service		8433 E 1000 N	Monticello	47960	(574) 270-8389	
Quality Construction Inc.		3076 N 800 E	Monticello	47960	(574) 583-7405	
Richard Blazer	Richard Blazer	2304 E 300 S	Kokomo	46902	(765) 453-5615	
Ridenour Excavating	Brian Ridenour	6629 S 400 E	Kirkland	46050	(765) 978-0205	ridenourkir@aol.com
Rinehart Enterprises LLC.	Darrell Rinehart	5262 W 750 S	Rossville	46065	(765) 714-2768	
Rinehart Excavating	Michael Rinehart	6155 W 550 S	Delphi	46923	(765) 379-2107	
Sparks Hauling	Nathan Sparks	538 E 700 S	Cutler	46920	(765) 412-8524	sparkshauling@yahoo.com
Titus Well Drilling, Inc	Vaughn Titus	2706 State Rd 225 E.	Battleground	47920	(765) 567-2516	judy@tituswelldrilling.com